

Madison, Wisconsin

INDEX OF SHEETS

SHEET NO.	TITLE
1	INDEX
DI-D2	DETAILS
RG1-RG2	RAIN GARDEN DETAILS
EC1-EC9	EROSION CONTROL PLANS
P1-P6	COMMONWEALTH PLAN & PROFILE
P7-P8	FOX PLAN & PROFILE
P9	GREGORY PLAN & PROFILE
P10	KEYES PLAN & PROFILE
U1-U6	COMMONWEALTH SEWER PLAN & PROFILE
U7-U8	FOX SEWER PLAN & PROFILE
U9	GREGORY SEWER PLAN & PROFILE
U10	KEYES SEWER PLAN & PROFILE
U-11	SANITARY SEWER SCHEDULE
U12-U13	STORM SEWER SCHEDULES
U14	TREATMENT DEVICE DETAIL
W1-W6	COMMONWEALTH WATER PLAN & PROFILE
W7-W8	FOX WATER PLAN & PROFILE
W9	GREGORY WATER PLAN & PROFILE
W10	KEYES WATER PLAN & PROFILE
W11	WATER MATERIALS, NOTES, DETAILS
W12-W14	WATER IMPACT PLANS
M1-M5	PAVEMENT MARKING PLANS
X1-X23	STREET CROSS SECTIONS

CONVENTIONAL SIGNS

FIELD VERIFY ALL UTILITY LOCATIONS

GAS	— G —
STORM SEWER	— ST —
SANITARY SEWER	— SAN —
WATER	— W —
OVERHEAD ELECTRIC	— OH —
POWER POLE	⊕
ADA COMPLIANT RAMP W/ DETECTABLE WARNING FIELD	
COMBUSTIBLE FLUIDS	

CONSTRUCTION PROJECT LOCATION

NOTES:

ALL GUTTERS SHALL DRAIN WITH A MINIMUM GRADE OF 0.50% TOWARD STORM SEWER INLETS.

SIDEWALK RAMPS AND CURB THRU SIDEWALK RAMPS SHALL HAVE A MAXIMUM SLOPE OF 1" PER 12". SIDEWALK AND CURB RAMPS SHALL BE CONSTRUCTED WITH A SIDE SLOPE OF 2.00%. SIDEWALK SHALL HAVE A MINIMUM LONGITUDINAL SLOPE OF 0.50% AND A MAXIMUM LONGITUDINAL SLOPE OF 5.00% EXCEPT WHERE STREET GRADES EXCEED 5.00%.

CITY OF MADISON

CITY ENGINEERING DIVISION
DEPARTMENT OF PUBLIC WORKS

PLAN OF PROPOSED IMPROVEMENT

COMMONWEALTH AVENUE, FOX AVENUE,
GREGORY STREET AND KEYES AVENUE
RECONSTRUCTION ASSESSMENT DISTRICT - 2014

CITY PROJECT NO. 53W0615

CITY CONTRACT NO. 7234

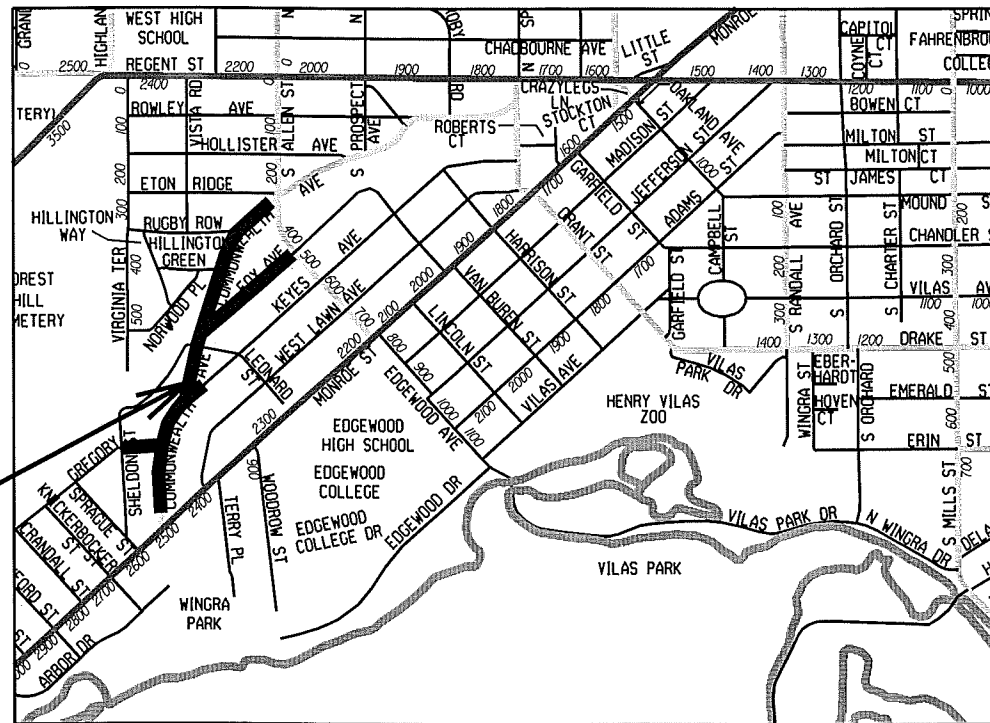
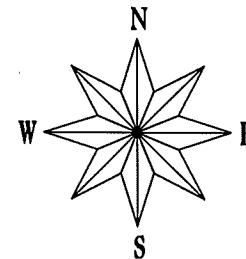

EARTH WORK SUMMARY:

EXCAVATION CUT (MEASURED PLAN QUANTITY).....	6655 C.Y.
ESTIMATED UNDISTRIBUTED UNDERCUT.....	1879 C.Y.
TOTAL UNCLASSIFIED EXCAVATION CUT.....	8534 C.Y.

PUBLIC IMPROVEMENT PROJECT APPROVED

MARCH 4, 2014

BY THE COMMON COUNCIL OF MADISON, WISCONSIN

PUBLIC IMPROVEMENT DESIGN APPROVED BY:

Christy Bach 3-31-14
City Engineer Date

STREET DESIGNED BY:

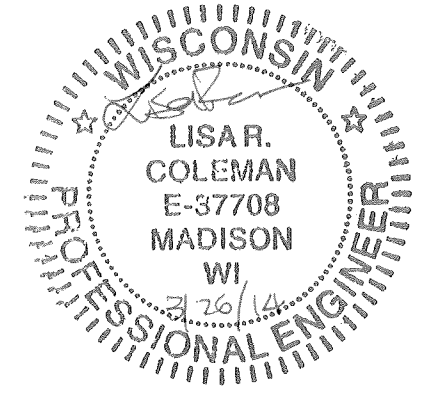

GEOMETRICS & PAVEMENT MARKING DESIGNED BY:



STORM SEWER DESIGNED BY:

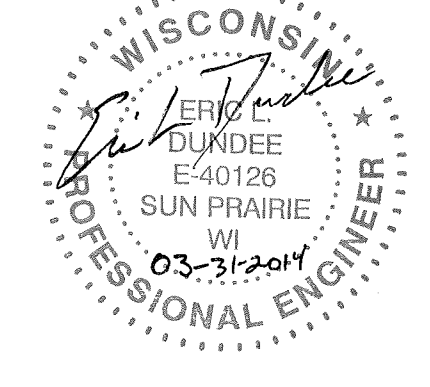

WATER DESIGNED BY:

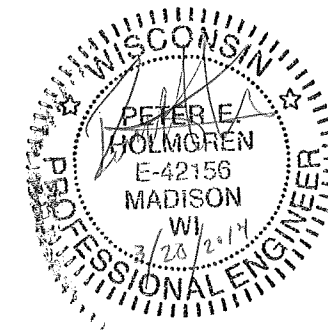

SANITARY SEWER DESIGNED BY:

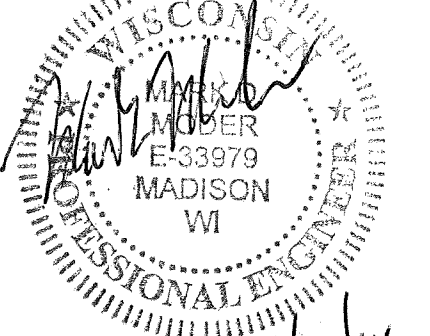

PLOT SCALE:

PLOT NAME:

REV. DATE:

ORIGINATOR: CITY OF MADISON, STREETS DIVISION

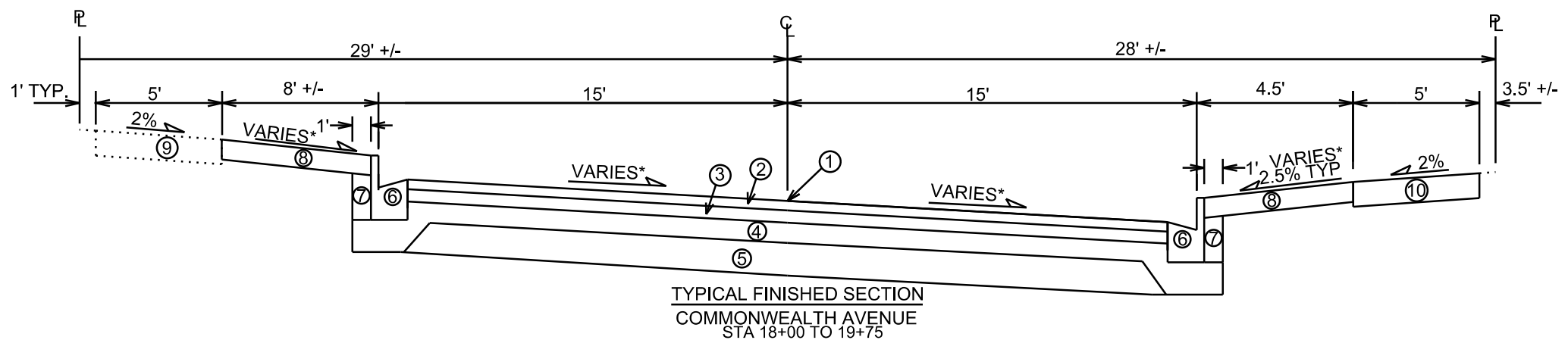
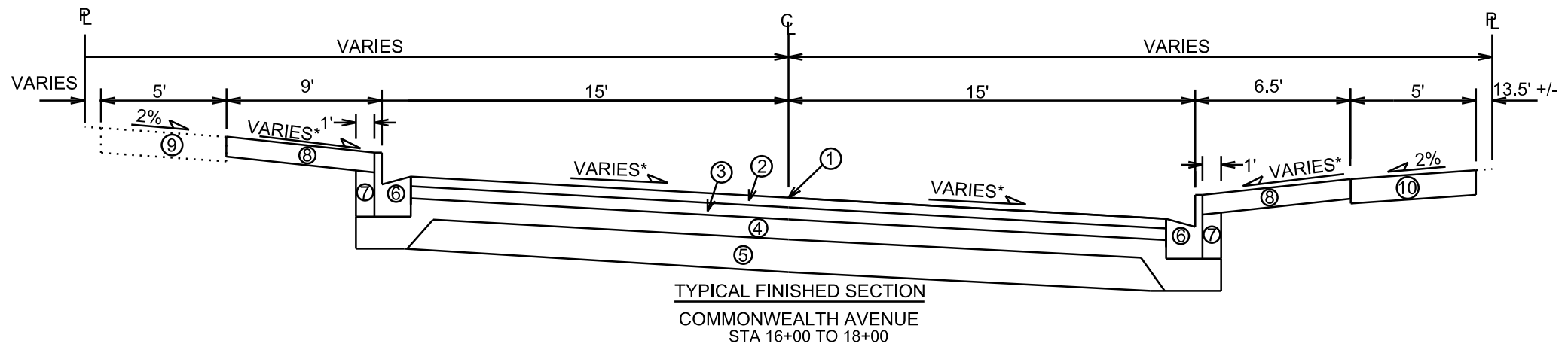
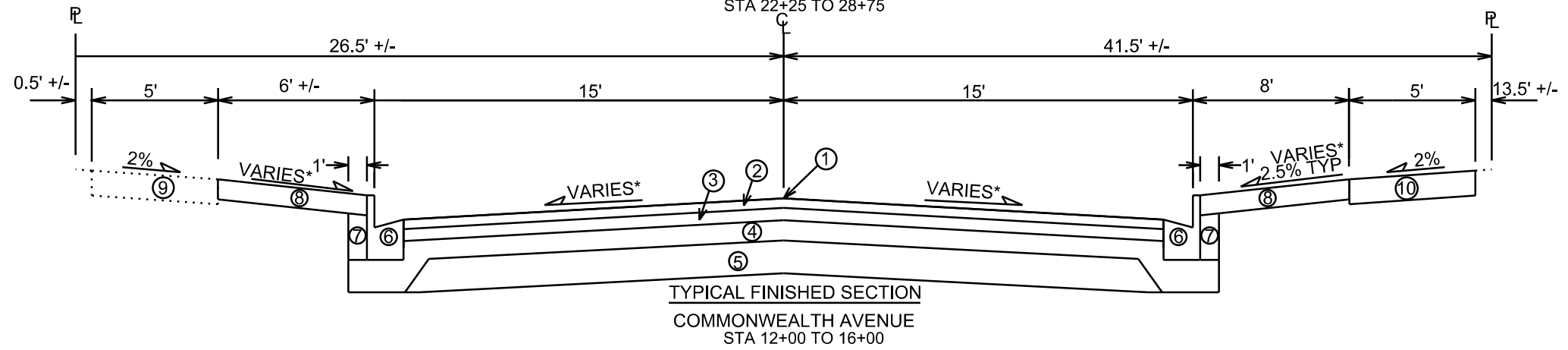
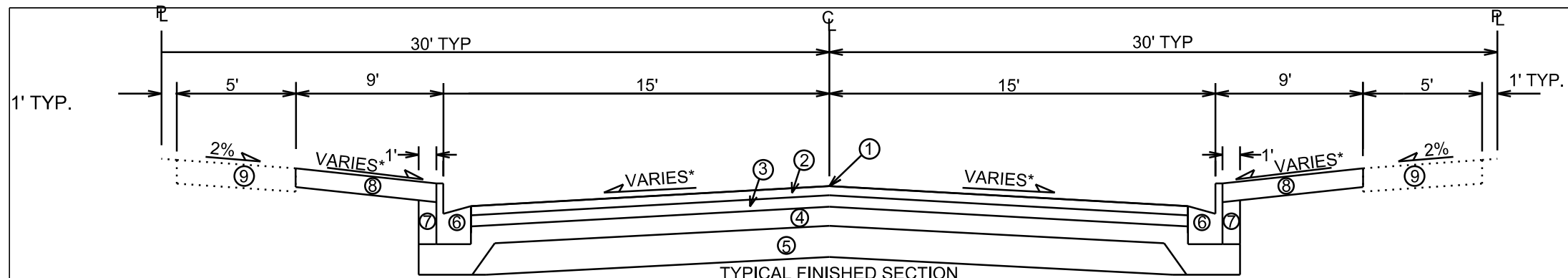

- ① POINT REFERRED TO ON PROFILE
- ② 2.00" BITUMINOUS UPPER LAYER, TYPE E-3
- ③ 3.25" BITUMINOUS LOWER LAYER, TYPE E-3
- ④ 4" GRADATION 2 CRUSHED STONE
- ⑤ 6" GRADATION 1 CRUSHED STONE
- ⑥ TYPE 'A' CONCRETE CURB & GUTTER
- ⑦ FILL, INCIDENTAL
- ⑧ 4" TOPSOIL, SEED & MAT
- ⑨ 5" CONCRETE SIDEWALK, REPLACE AS NOTED ON PLAN
- ⑩ NEW 5" CONCRETE SIDEWALK

* SEE CROSS SECTION SHEETS FOR CROSS SLOPES AND TOP OF CURB ELEVATIONS.
TYPICAL SECTIONS NOT TO SCALE

NOTE: AT BUMPOUT LOCATIONS, THE MINIMUM DIMENSION ON THE LEFT SIDE FROM THE CENTERLINE TO THE CURB IS EITHER 10 FT, 11 FT, OR 12 FT. SEE PLAN AND CROSS SECTIONS FOR BUMPOUT LOCATIONS AND DIMENSIONS.

PLOT SCALE: _____
PLOT NAME: _____
REV. DATE: _____
ORIGINATOR: CITY OF MADISON, STREETS DIVISION

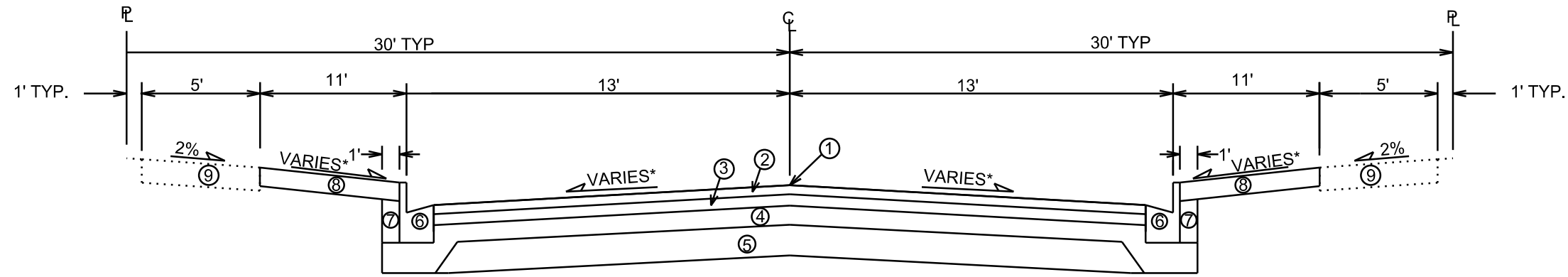

TYPICAL FINISHED SECTION
FOX AVENUE
STA 41+50 TO 49+30

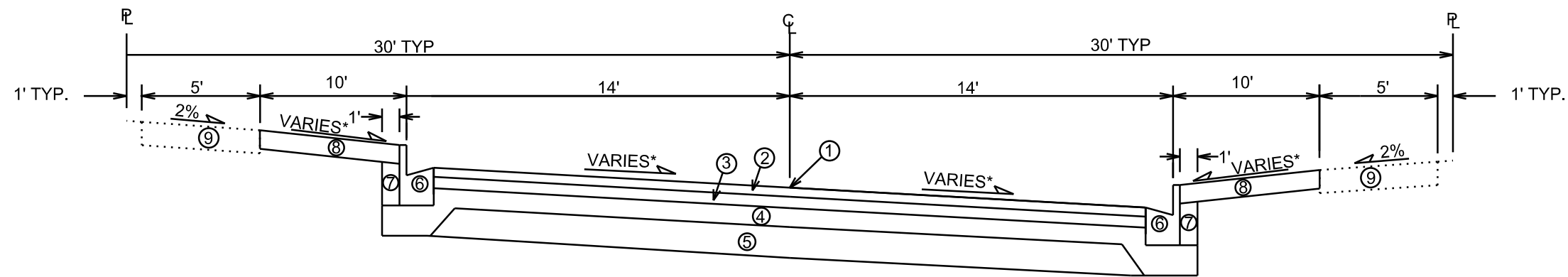

TYPICAL FINISHED SECTION
GREGORY STREET
STA 30+30 TO 33+00

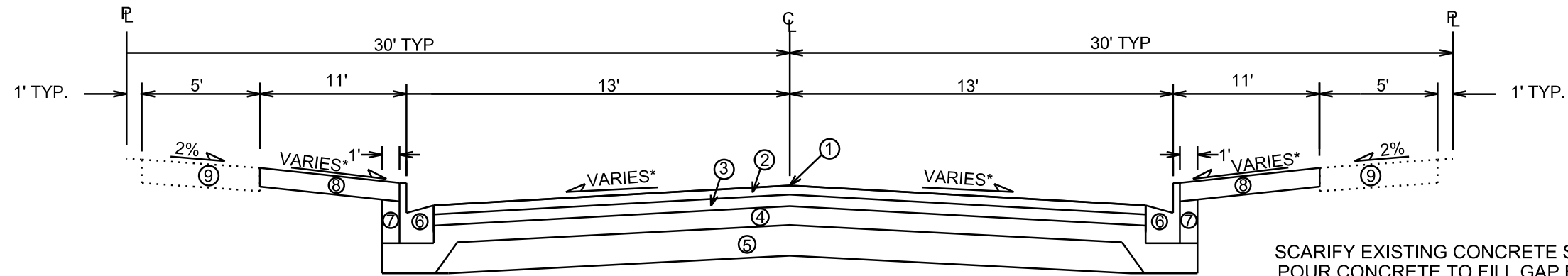

TYPICAL FINISHED SECTION
KEYES AVENUE
STA 2+75 TO 3+50

- ① POINT REFERRED TO ON PROFILE
- ② 1.75" BITUMINOUS UPPER LAYER, TYPE E-0.3
- ③ 1.75" BITUMINOUS LOWER LAYER, TYPE E-0.3
- ④ 4" GRADATION 2 CRUSHED STONE
- ⑤ 6" GRADATION 1 CRUSHED STONE
- ⑥ TYPE 'A' CONCRETE CURB & GUTTER
- ⑦ FILL, INCIDENTAL
- ⑧ 4" TOPSOIL, SEED & MAT
- ⑨ 5" CONCRETE SIDEWALK, REPLACE AS NOTED ON PLAN

* SEE CROSS SECTION SHEETS FOR CROSS SLOPES AND TOP OF CURB ELEVATIONS.
TYPICAL SECTIONS NOT TO SCALE

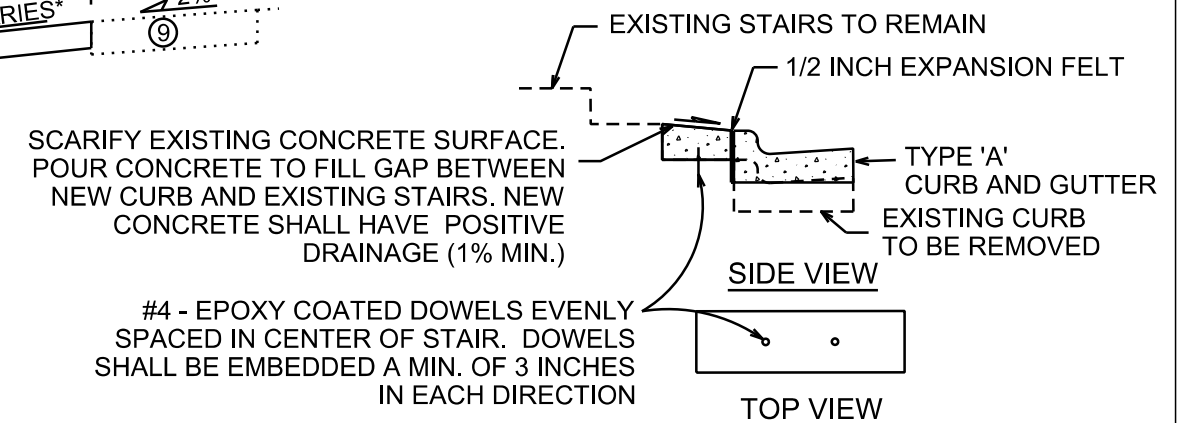

REPAIR CONCRETE STEPS

PLOT SCALE: _____
PLOT NAME: _____
REV. DATE: _____
ORIGINATOR: CITY OF MADISON, STREETS DIVISION

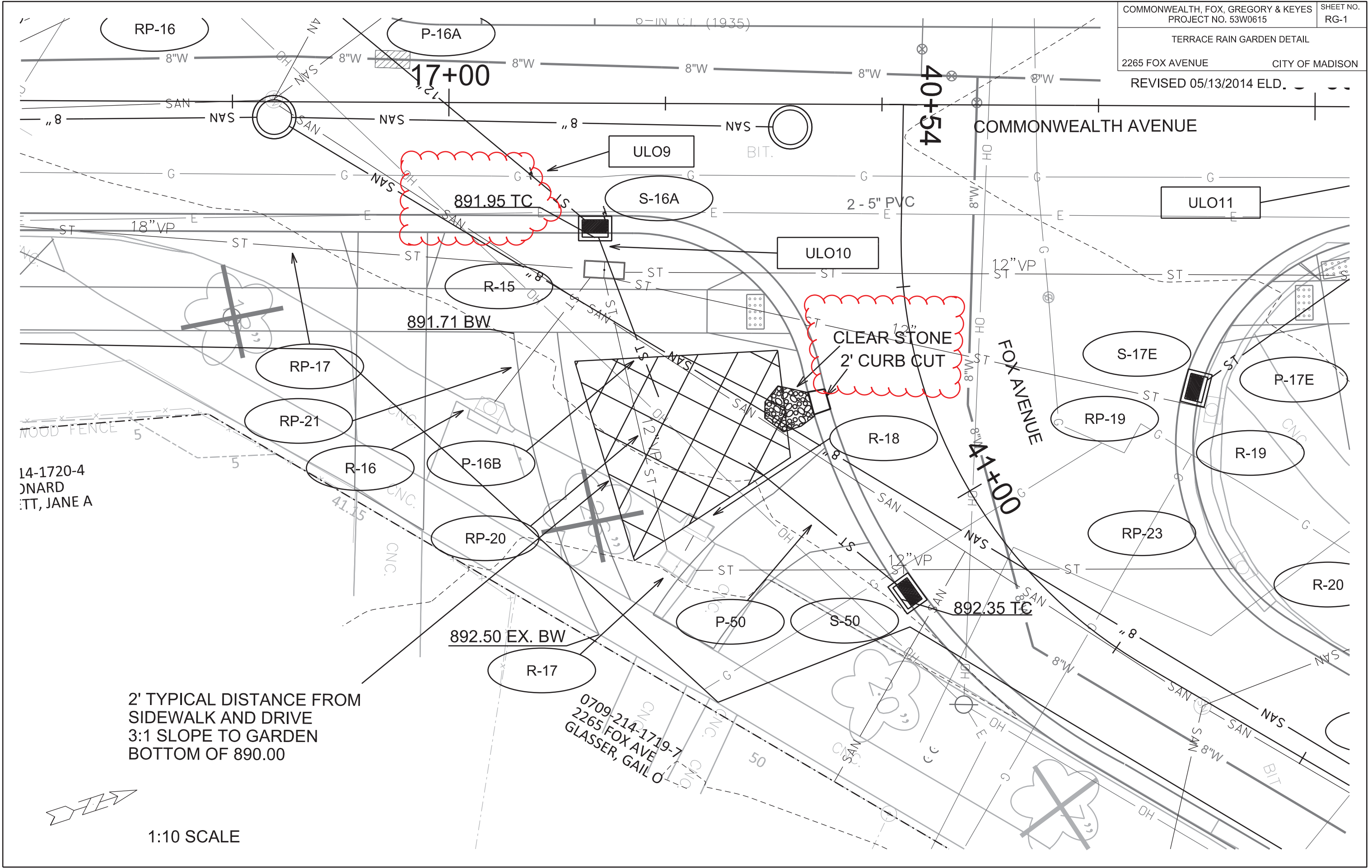

14-1720-4
 DONARD
 ST, JANE A

2' TYPICAL DISTANCE FROM
 SIDEWALK AND DRIVE
 3:1 SLOPE TO GARDEN
 BOTTOM OF 890.00

0709-214-1719-7
 2265 FOX AVE
 GLASSER, GAIL O

1:10 SCALE

PLOT SCALE: _____
 PLOT NAME: _____
 REV. DATE: _____
 ORIGINATOR: CITY OF MADISON, STREETS DIVISION

1:10 SCALE

0709-214-1607-4
 2246 FOX AVE
 MOYNIHAN, DONALD P
 PAMELA HERD

0709-214-1608-2
 2242 FOX AVE
 WOOD, PHILIP J & MELANIE

0709-214-1609
 2234 FOX AVE
 STRAAVALDSEN
 AND DEBORAH

1' TYPICAL DISTANCE FROM
 SIDEWALK AND DRIVE
 3:1 SLOPE TO GARDEN
 BOTTOM OF 898.75

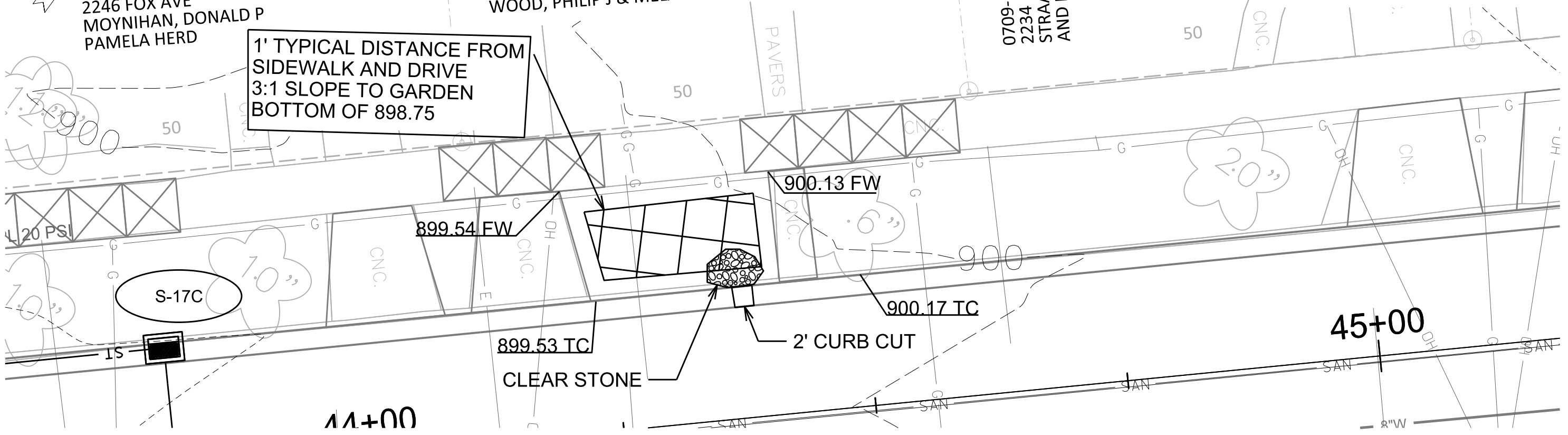

0709-214-1608-1
 2214 FOX AVE
 KONOPACKI, PAUL J
 & ELIZABETH BUCAIDA

2210 FOX AVE
 KUEHLING, HARLAN H
 & JANET K O'NEILL

1' TYPICAL DISTANCE FROM
 SIDEWALK AND DRIVE, 10'
 FROM TREET, 3:1 SLOPE TO
 GARDEN BOTTOM OF 910.36

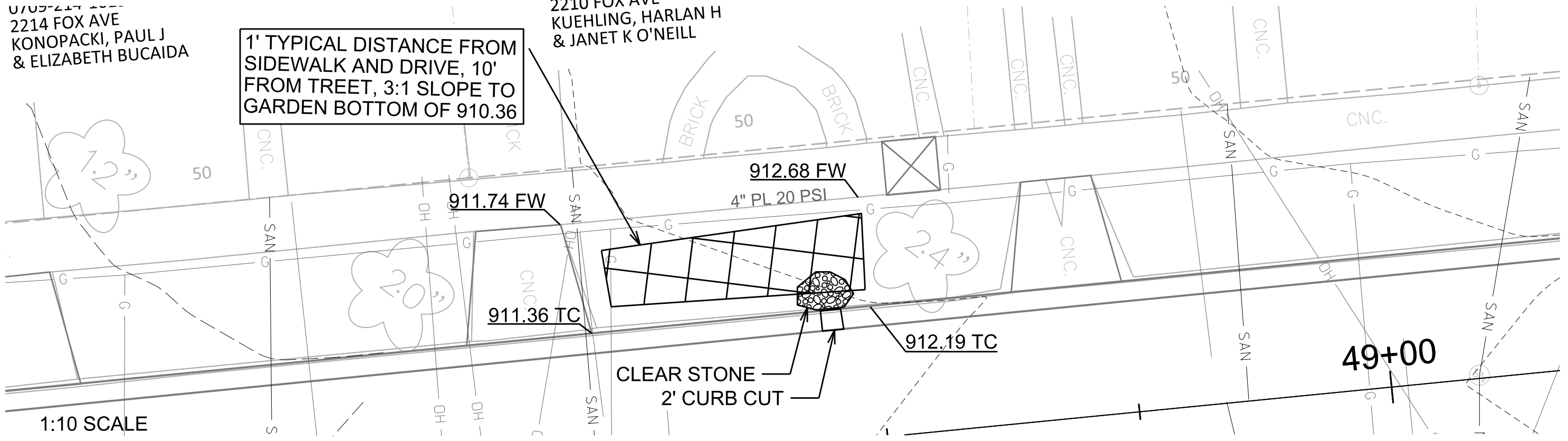





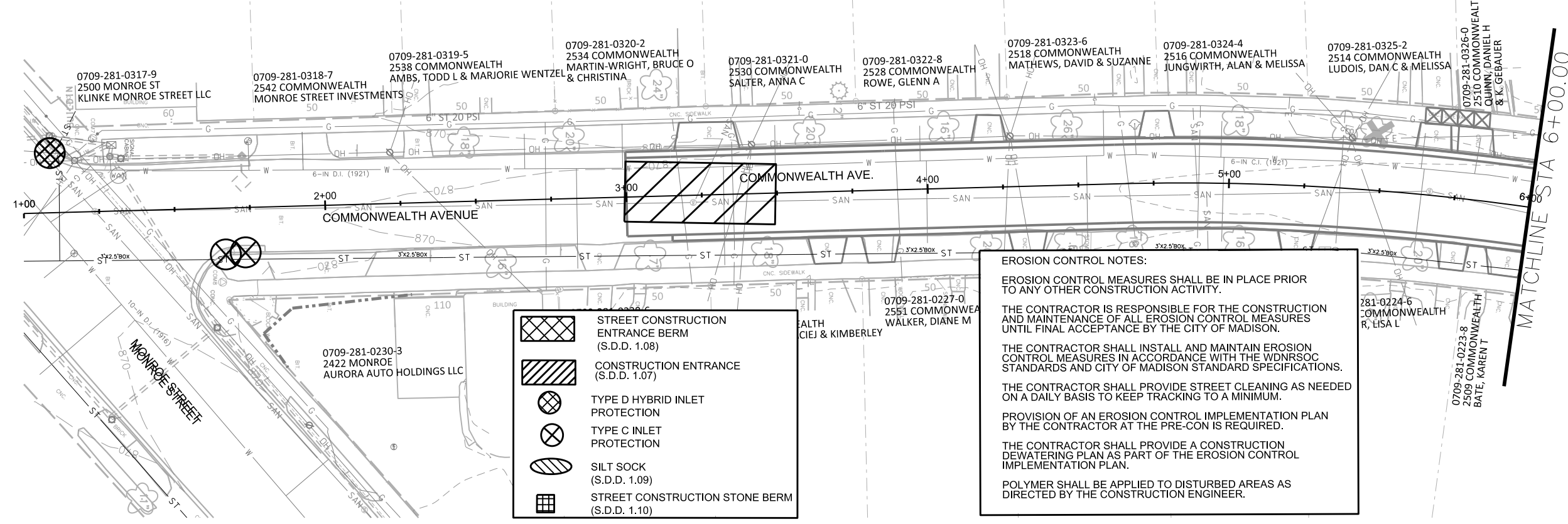
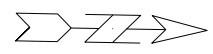

1:10 SCALE

PLOT SCALE: _____
 PLOT NAME: _____
 REV. DATE: _____
 ORIGINATOR: CITY OF MADISON, STREETS DIVISION

CONTRACTOR SHALL REM & REP
SIDEWALK AS NEEDED FOR LATERALS
(MAX. OF 4 SW SQUARES PER LATERAL)



-  STREET CONSTRUCTION ENTRANCE BERM (S.D.D. 1.08)
-  CONSTRUCTION ENTRANCE (S.D.D. 1.07)
-  TYPE D HYBRID INLET PROTECTION
-  TYPE C INLET PROTECTION
-  SILT SOCK (S.D.D. 1.09)
-  STREET CONSTRUCTION STONE BERM (S.D.D. 1.10)

EROSION CONTROL NOTES:

EROSION CONTROL MEASURES SHALL BE IN PLACE PRIOR TO ANY OTHER CONSTRUCTION ACTIVITY.

THE CONTRACTOR IS RESPONSIBLE FOR THE CONSTRUCTION AND MAINTENANCE OF ALL EROSION CONTROL MEASURES UNTIL FINAL ACCEPTANCE BY THE CITY OF MADISON.

THE CONTRACTOR SHALL INSTALL AND MAINTAIN EROSION CONTROL MEASURES IN ACCORDANCE WITH THE WDNRSOC STANDARDS AND CITY OF MADISON STANDARD SPECIFICATIONS.

THE CONTRACTOR SHALL PROVIDE STREET CLEANING AS NEEDED ON A DAILY BASIS TO KEEP TRACKING TO A MINIMUM.

PROVISION OF AN EROSION CONTROL IMPLEMENTATION PLAN BY THE CONTRACTOR AT THE PRE-CON IS REQUIRED.

THE CONTRACTOR SHALL PROVIDE A CONSTRUCTION DEWATERING PLAN AS PART OF THE EROSION CONTROL IMPLEMENTATION PLAN.





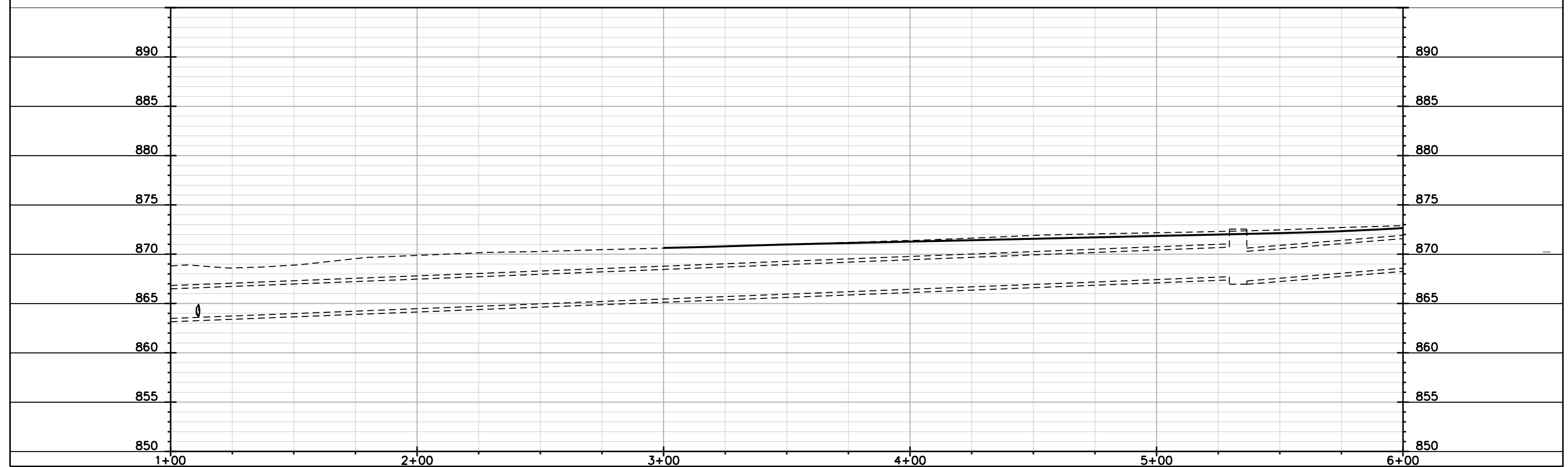

POLYMER SHALL BE APPLIED TO DISTURBED AREAS AS DIRECTED BY THE CONSTRUCTION ENGINEER.

PLOT SCALE: _____

REV. DATE: _____

ORIGINATOR: CITY OF MADISON, STREETS DIVISION



-  STREET CONSTRUCTION ENTRANCE BERM (S.D.D. 1.08)
-  CONSTRUCTION ENTRANCE (S.D.D. 1.07)
-  TYPE D HYBRID INLET PROTECTION
-  TYPE C INLET PROTECTION
-  SILT SOCK (S.D.D. 1.09)
-  STREET CONSTRUCTION STONE BERM (S.D.D. 1.10)

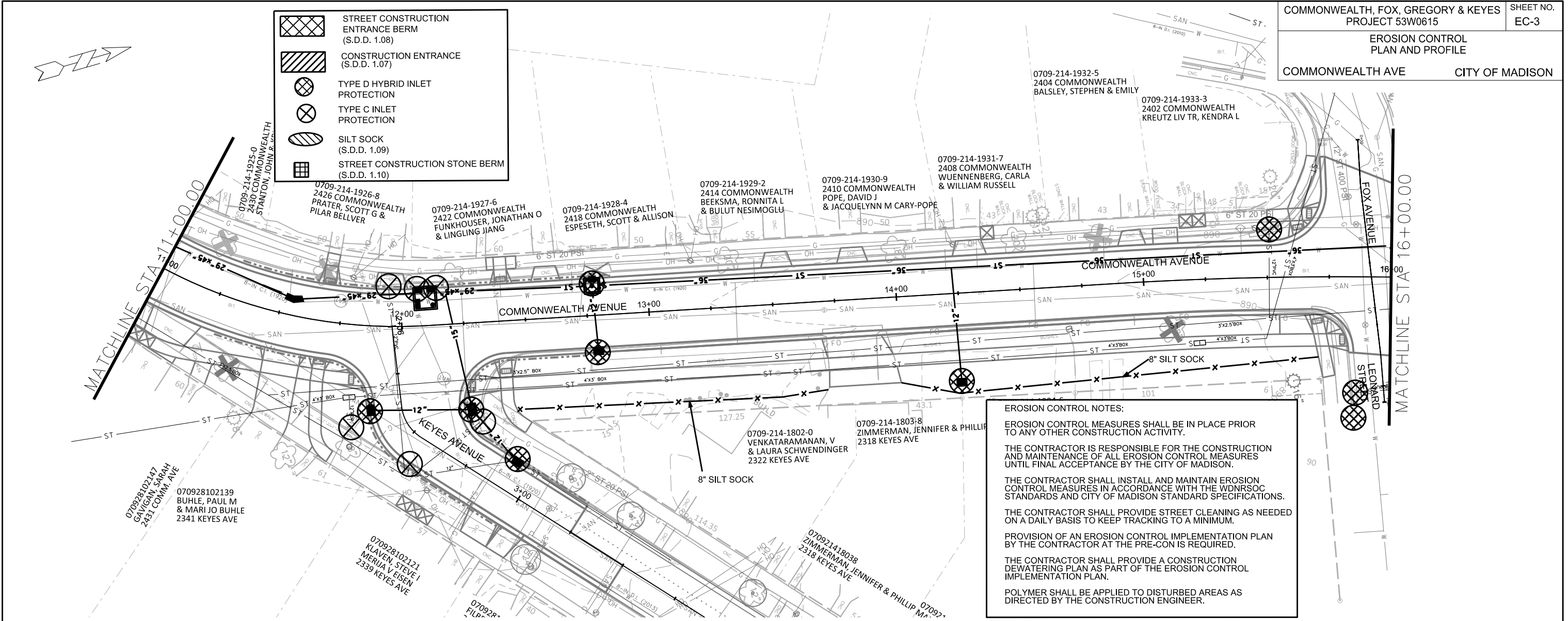

EROSION CONTROL NOTES:

EROSION CONTROL MEASURES SHALL BE IN PLACE PRIOR TO ANY OTHER CONSTRUCTION ACTIVITY.

THE CONTRACTOR IS RESPONSIBLE FOR THE CONSTRUCTION AND MAINTENANCE OF ALL EROSION CONTROL MEASURES UNTIL FINAL ACCEPTANCE BY THE CITY OF MADISON.

THE CONTRACTOR SHALL INSTALL AND MAINTAIN EROSION CONTROL MEASURES IN ACCORDANCE WITH THE WDNR SOC STANDARDS AND CITY OF MADISON STANDARD SPECIFICATIONS.

THE CONTRACTOR SHALL PROVIDE STREET CLEANING AS NEEDED ON A DAILY BASIS TO KEEP TRACKING TO A MINIMUM.

PROVISION OF AN EROSION CONTROL IMPLEMENTATION PLAN BY THE CONTRACTOR AT THE PRE-CON IS REQUIRED.

THE CONTRACTOR SHALL PROVIDE A CONSTRUCTION DEWATERING PLAN AS PART OF THE EROSION CONTROL IMPLEMENTATION PLAN.

POLYMER SHALL BE APPLIED TO DISTURBED AREAS AS DIRECTED BY THE CONSTRUCTION ENGINEER.

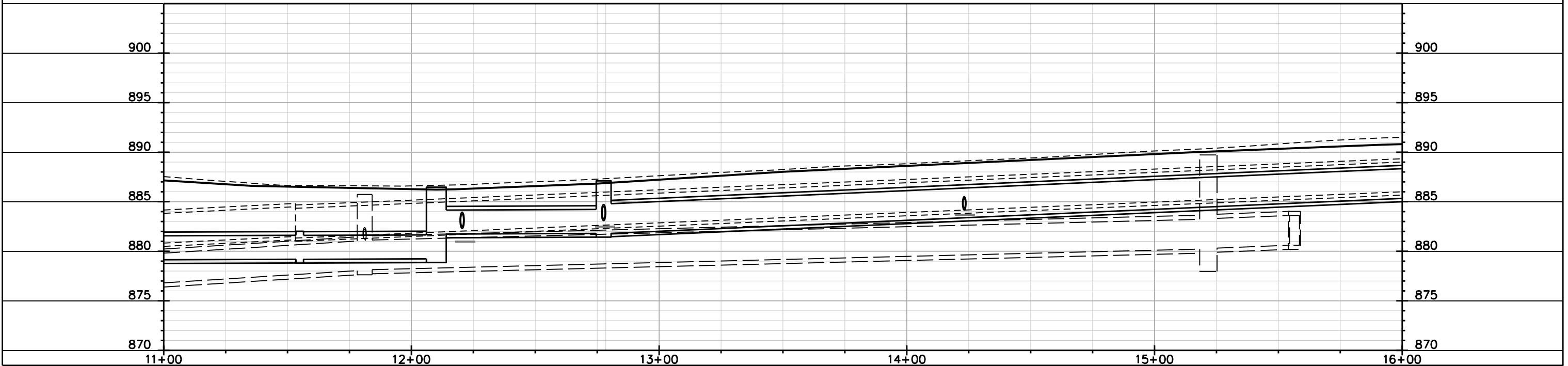

PLOT SCALE: _____
PLOT NAME: _____
REV. DATE: _____

ORIGINATOR: CITY OF MADISON, STREETS DIVISION

EROSION CONTROL NOTES:

EROSION CONTROL MEASURES SHALL BE IN PLACE PRIOR TO ANY OTHER CONSTRUCTION ACTIVITY.

THE CONTRACTOR IS RESPONSIBLE FOR THE CONSTRUCTION AND MAINTENANCE OF ALL EROSION CONTROL MEASURES UNTIL FINAL ACCEPTANCE BY THE CITY OF MADISON.







THE CONTRACTOR SHALL INSTALL AND MAINTAIN EROSION CONTROL MEASURES IN ACCORDANCE WITH THE WDNRSOC STANDARDS AND CITY OF MADISON STANDARD SPECIFICATIONS.

THE CONTRACTOR SHALL PROVIDE STREET CLEANING AS NEEDED ON A DAILY BASIS TO KEEP TRACKING TO A MINIMUM.

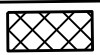
PROVISION OF AN EROSION CONTROL IMPLEMENTATION PLAN BY THE CONTRACTOR AT THE PRE-CON IS REQUIRED.

THE CONTRACTOR SHALL PROVIDE A CONSTRUCTION DEWATERING PLAN AS PART OF THE EROSION CONTROL IMPLEMENTATION PLAN.

POLYMER SHALL BE APPLIED TO DISTURBED AREAS AS DIRECTED BY THE CONSTRUCTION ENGINEER.

-  STREET CONSTRUCTION ENTRANCE BERM (S.D.D. 1.08)
-  CONSTRUCTION ENTRANCE (S.D.D. 1.07)
-  TYPE D HYBRID INLET PROTECTION
-  TYPE C INLET PROTECTION
-  SILT SOCK (S.D.D. 1.09)
-  STREET CONSTRUCTION STONE BERM (S.D.D. 1.10)

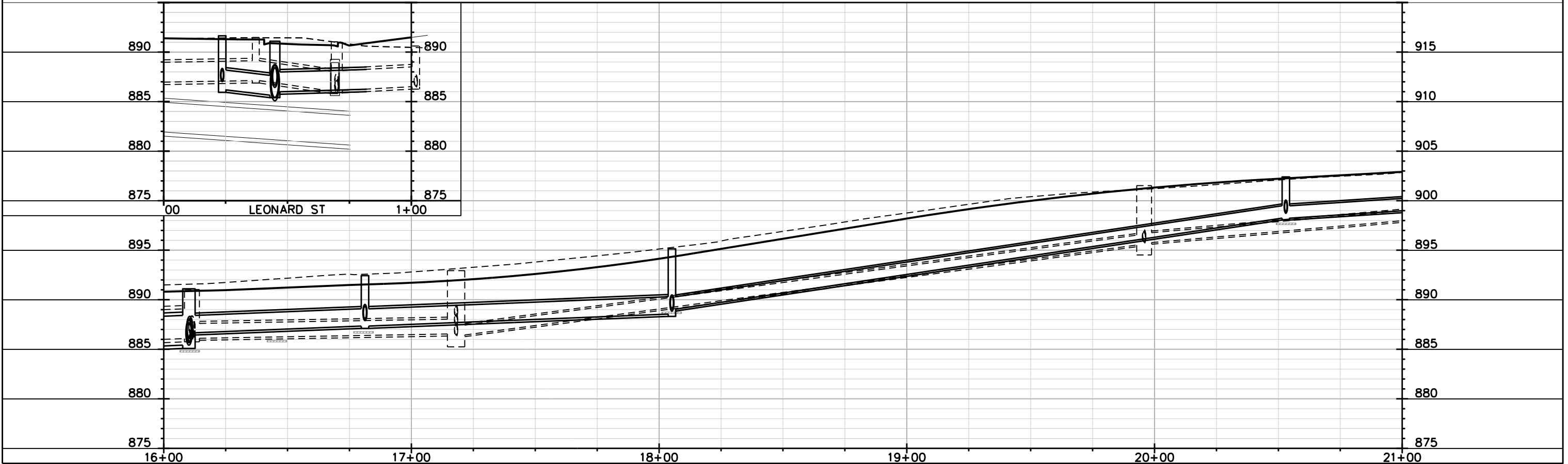
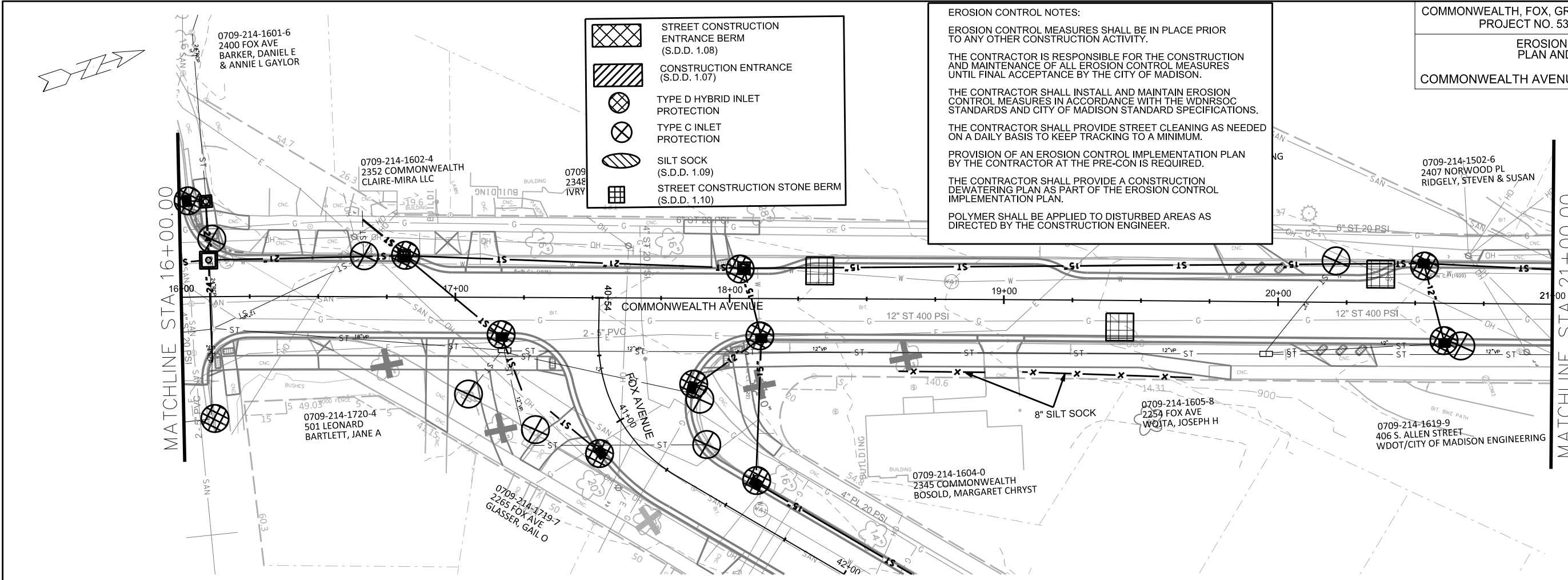

PLOT SCALE: _____

REV. DATE: _____

ORIGINATOR: CITY OF MADISON, STREETS DIVISION

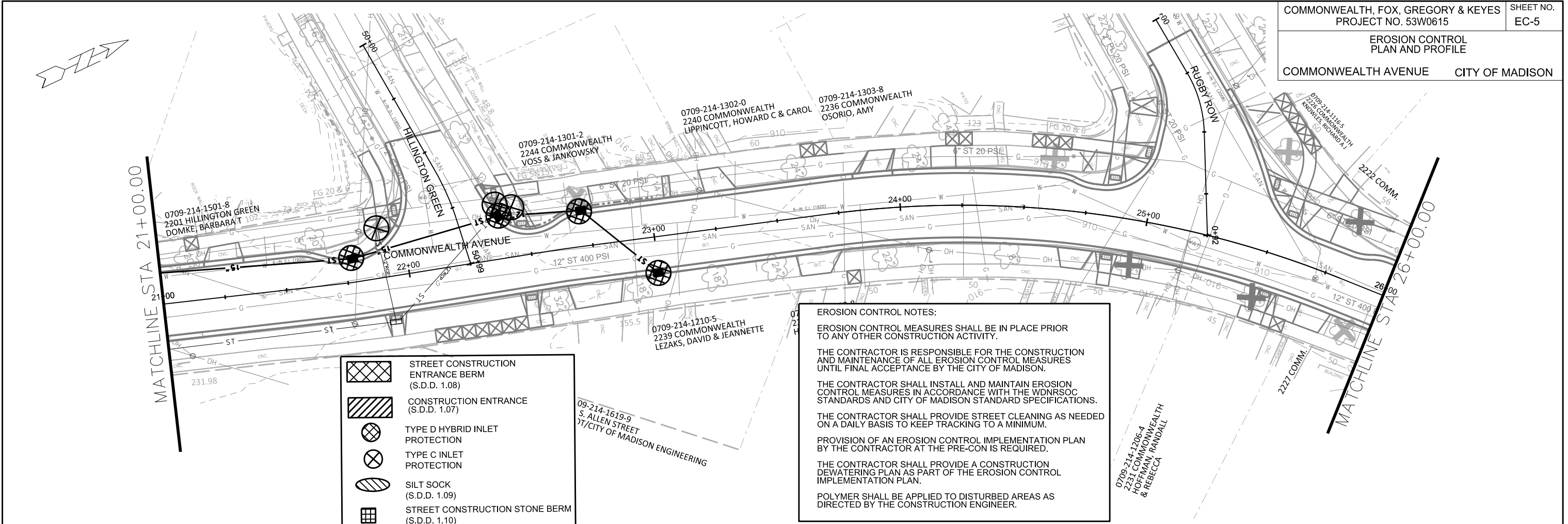

EROSION CONTROL NOTES:

EROSION CONTROL MEASURES SHALL BE IN PLACE PRIOR TO ANY OTHER CONSTRUCTION ACTIVITY.

THE CONTRACTOR IS RESPONSIBLE FOR THE CONSTRUCTION AND MAINTENANCE OF ALL EROSION CONTROL MEASURES UNTIL FINAL ACCEPTANCE BY THE CITY OF MADISON.

THE CONTRACTOR SHALL INSTALL AND MAINTAIN EROSION CONTROL MEASURES IN ACCORDANCE WITH THE WDNR SOC STANDARDS AND CITY OF MADISON STANDARD SPECIFICATIONS.

THE CONTRACTOR SHALL PROVIDE STREET CLEANING AS NEEDED ON A DAILY BASIS TO KEEP TRACKING TO A MINIMUM.

PROVISION OF AN EROSION CONTROL IMPLEMENTATION PLAN BY THE CONTRACTOR AT THE PRE-CON IS REQUIRED.







THE CONTRACTOR SHALL PROVIDE A CONSTRUCTION DEWATERING PLAN AS PART OF THE EROSION CONTROL IMPLEMENTATION PLAN.

POLYMER SHALL BE APPLIED TO DISTURBED AREAS AS DIRECTED BY THE CONSTRUCTION ENGINEER.



EROSION CONTROL
PLAN AND PROFILE

COMMONWEALTH AVENUE CITY OF MADISON

-  STREET CONSTRUCTION ENTRANCE BERM (S.D.D. 1.08)
-  CONSTRUCTION ENTRANCE (S.D.D. 1.07)
-  TYPE D HYBRID INLET PROTECTION
-  TYPE C INLET PROTECTION
-  SILT SOCK (S.D.D. 1.09)
-  STREET CONSTRUCTION STONE BERM (S.D.D. 1.10)

EROSION CONTROL NOTES:

EROSION CONTROL MEASURES SHALL BE IN PLACE PRIOR TO ANY OTHER CONSTRUCTION ACTIVITY.

THE CONTRACTOR IS RESPONSIBLE FOR THE CONSTRUCTION AND MAINTENANCE OF ALL EROSION CONTROL MEASURES UNTIL FINAL ACCEPTANCE BY THE CITY OF MADISON.

THE CONTRACTOR SHALL INSTALL AND MAINTAIN EROSION CONTROL MEASURES IN ACCORDANCE WITH THE WDNR SOC STANDARDS AND CITY OF MADISON STANDARD SPECIFICATIONS.

THE CONTRACTOR SHALL PROVIDE STREET CLEANING AS NEEDED ON A DAILY BASIS TO KEEP TRACKING TO A MINIMUM.

PROVISION OF AN EROSION CONTROL IMPLEMENTATION PLAN BY THE CONTRACTOR AT THE PRE-CON IS REQUIRED.





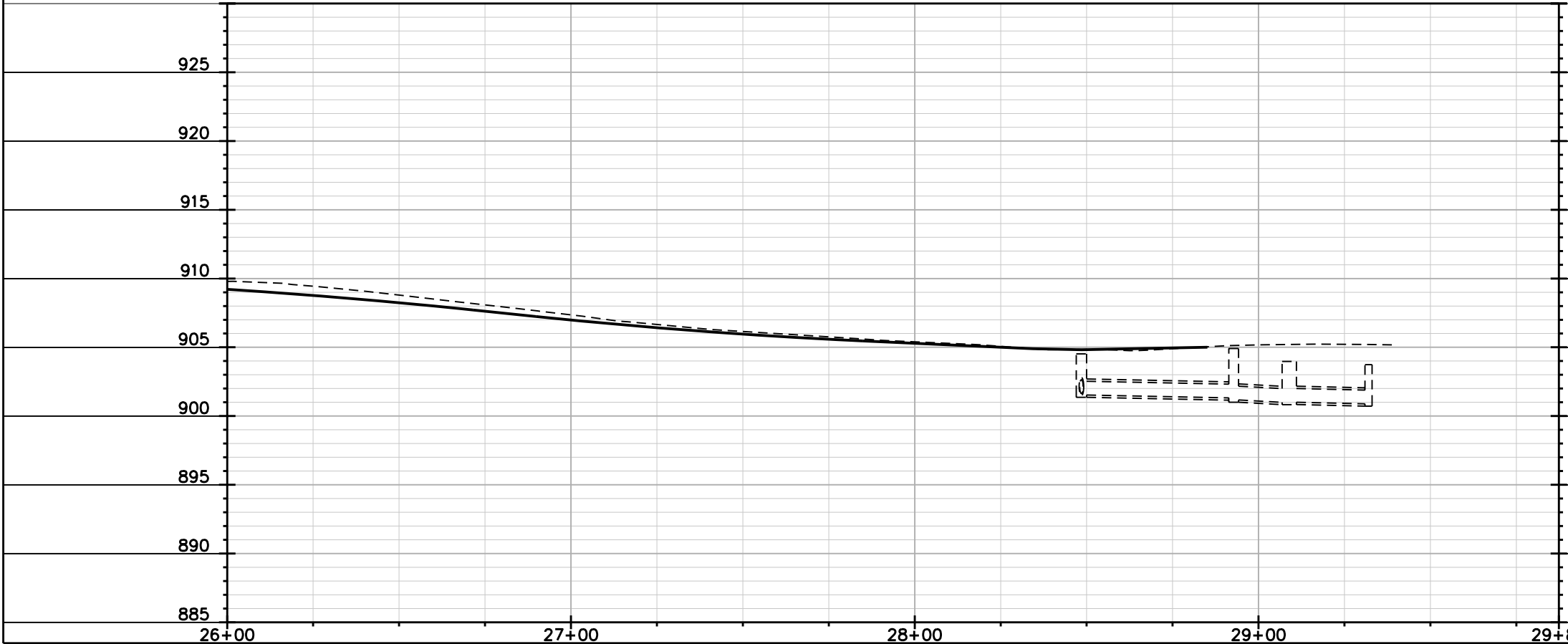
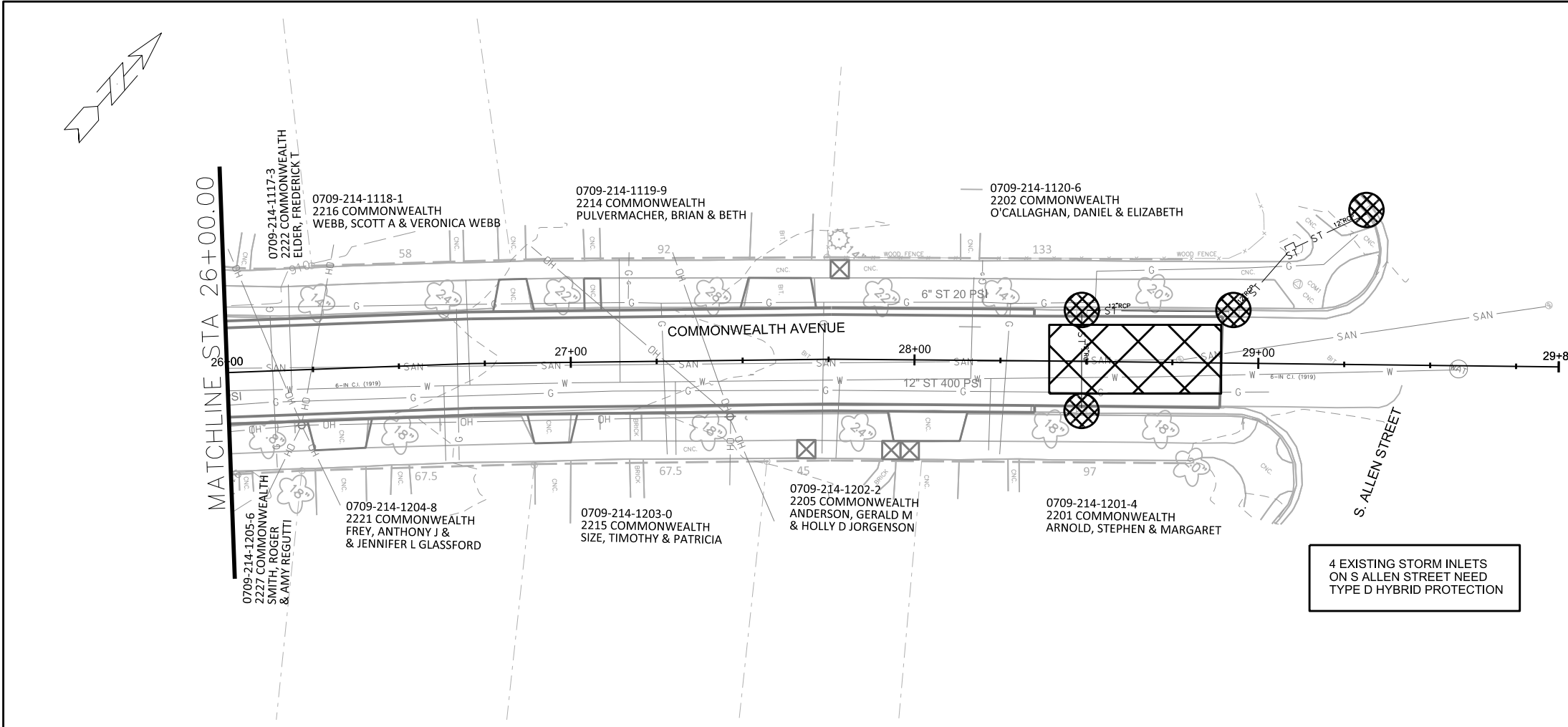

THE CONTRACTOR SHALL PROVIDE A CONSTRUCTION DEWATERING PLAN AS PART OF THE EROSION CONTROL IMPLEMENTATION PLAN.

POLYMER SHALL BE APPLIED TO DISTURBED AREAS AS DIRECTED BY THE CONSTRUCTION ENGINEER.

4 EXISTING STORM INLETS ON S ALLEN STREET NEED TYPE D HYBRID PROTECTION



PLOT SCALE: _____ PLOT NAME: _____ REV. DATE: _____

-  STREET CONSTRUCTION ENTRANCE BERM (S.D.D. 1.08)
-  CONSTRUCTION ENTRANCE (S.D.D. 1.07)
-  TYPE D HYBRID INLET PROTECTION
-  TYPE C INLET PROTECTION
-  SILT SOCK (S.D.D. 1.09)
-  STREET CONSTRUCTION STONE BERM (S.D.D. 1.10)

EROSION CONTROL NOTES:

EROSION CONTROL MEASURES SHALL BE IN PLACE PRIOR TO ANY OTHER CONSTRUCTION ACTIVITY.

THE CONTRACTOR IS RESPONSIBLE FOR THE CONSTRUCTION AND MAINTENANCE OF ALL EROSION CONTROL MEASURES UNTIL FINAL ACCEPTANCE BY THE CITY OF MADISON.

THE CONTRACTOR SHALL INSTALL AND MAINTAIN EROSION CONTROL MEASURES IN ACCORDANCE WITH THE WDNR SOC STANDARDS AND CITY OF MADISON STANDARD SPECIFICATIONS.

THE CONTRACTOR SHALL PROVIDE STREET CLEANING AS NEEDED ON A DAILY BASIS TO KEEP TRACKING TO A MINIMUM.

PROVISION OF AN EROSION CONTROL IMPLEMENTATION PLAN BY THE CONTRACTOR AT THE PRE-CON IS REQUIRED.

THE CONTRACTOR SHALL PROVIDE A CONSTRUCTION DEWATERING PLAN AS PART OF THE EROSION CONTROL IMPLEMENTATION PLAN.

POLYMER SHALL BE APPLIED TO DISTURBED AREAS AS DIRECTED BY THE CONSTRUCTION ENGINEER.



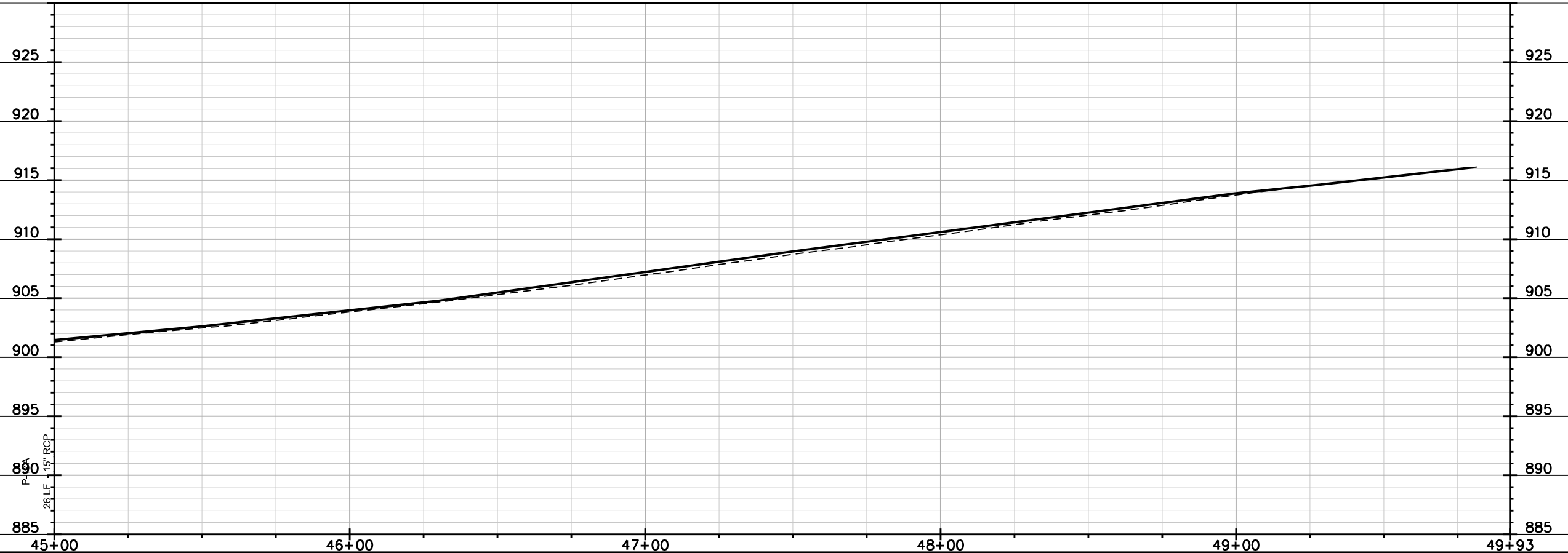
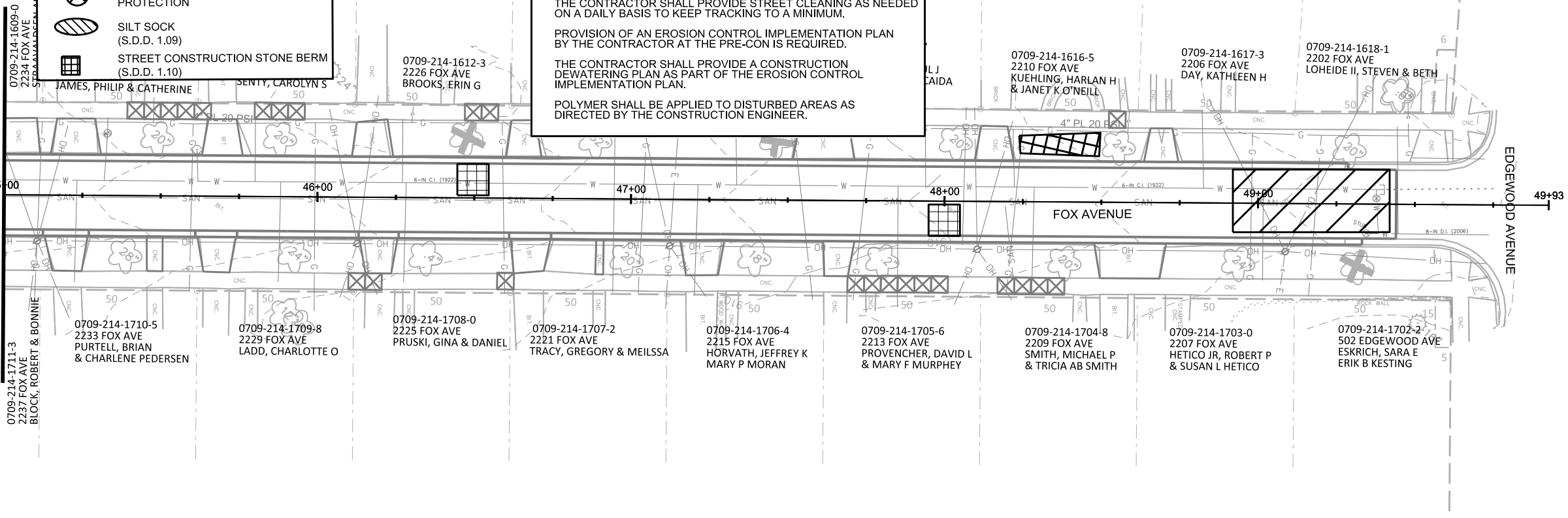



MATCHLINE STA 45+00.00



PLOT SCALE: _____ PLOT NAME: _____ REV. DATE: _____

ORIGINATOR: CITY OF MADISON, STREETS DIVISION

EROSION CONTROL
PLAN AND PROFILE
GREGORY STREET CITY OF MADISON

-  STREET CONSTRUCTION ENTRANCE BERM (S.D.D. 1.08)
-  CONSTRUCTION ENTRANCE (S.D.D. 1.07)
-  TYPE D HYBRID INLET PROTECTION
-  TYPE C INLET PROTECTION
-  SILT SOCK (S.D.D. 1.09)
-  STREET CONSTRUCTION STONE BERM (S.D.D. 1.10)

EROSION CONTROL NOTES:

EROSION CONTROL MEASURES SHALL BE IN PLACE PRIOR TO ANY OTHER CONSTRUCTION ACTIVITY.

THE CONTRACTOR IS RESPONSIBLE FOR THE CONSTRUCTION AND MAINTENANCE OF ALL EROSION CONTROL MEASURES UNTIL FINAL ACCEPTANCE BY THE CITY OF MADISON.

THE CONTRACTOR SHALL INSTALL AND MAINTAIN EROSION CONTROL MEASURES IN ACCORDANCE WITH THE WDNR SOC STANDARDS AND CITY OF MADISON STANDARD SPECIFICATIONS.

THE CONTRACTOR SHALL PROVIDE STREET CLEANING AS NEEDED ON A DAILY BASIS TO KEEP TRACKING TO A MINIMUM.

PROVISION OF AN EROSION CONTROL IMPLEMENTATION PLAN BY THE CONTRACTOR AT THE PRE-CON IS REQUIRED.

THE CONTRACTOR SHALL PROVIDE A CONSTRUCTION DEWATERING PLAN AS PART OF THE EROSION CONTROL IMPLEMENTATION PLAN.

POLYMER SHALL BE APPLIED TO DISTURBED AREAS AS DIRECTED BY THE CONSTRUCTION ENGINEER.

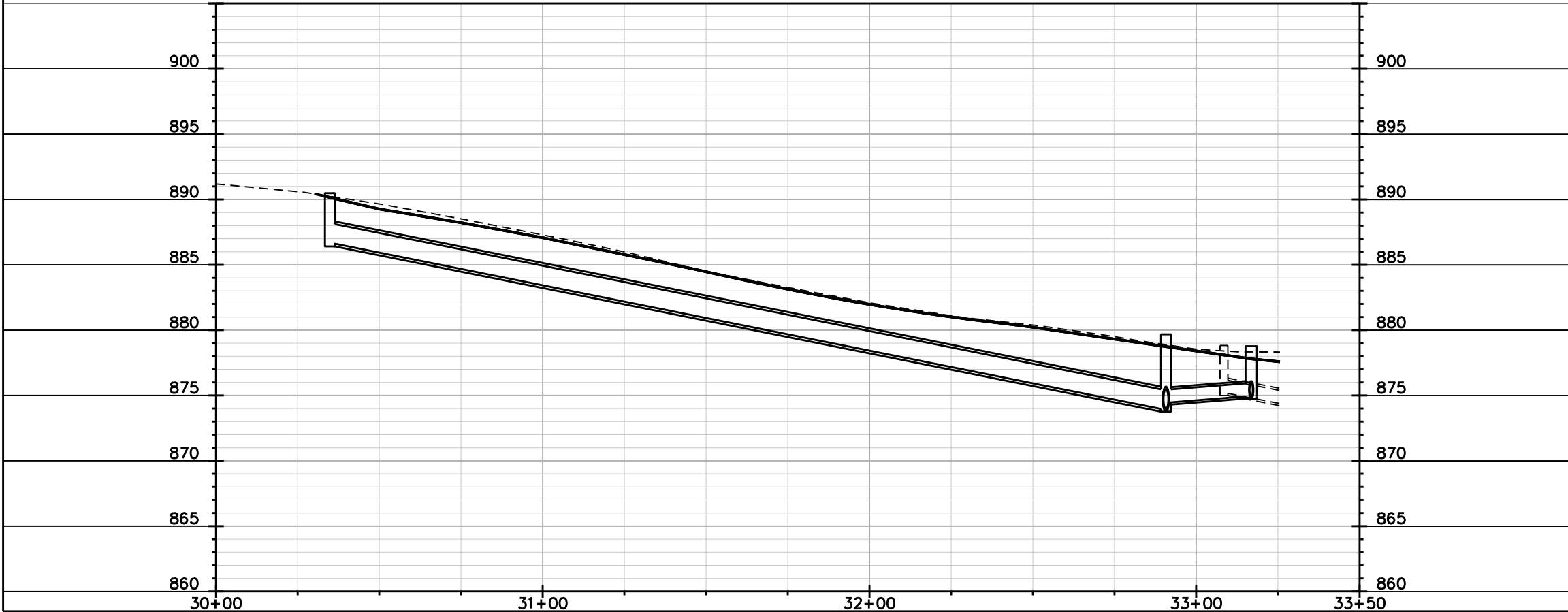
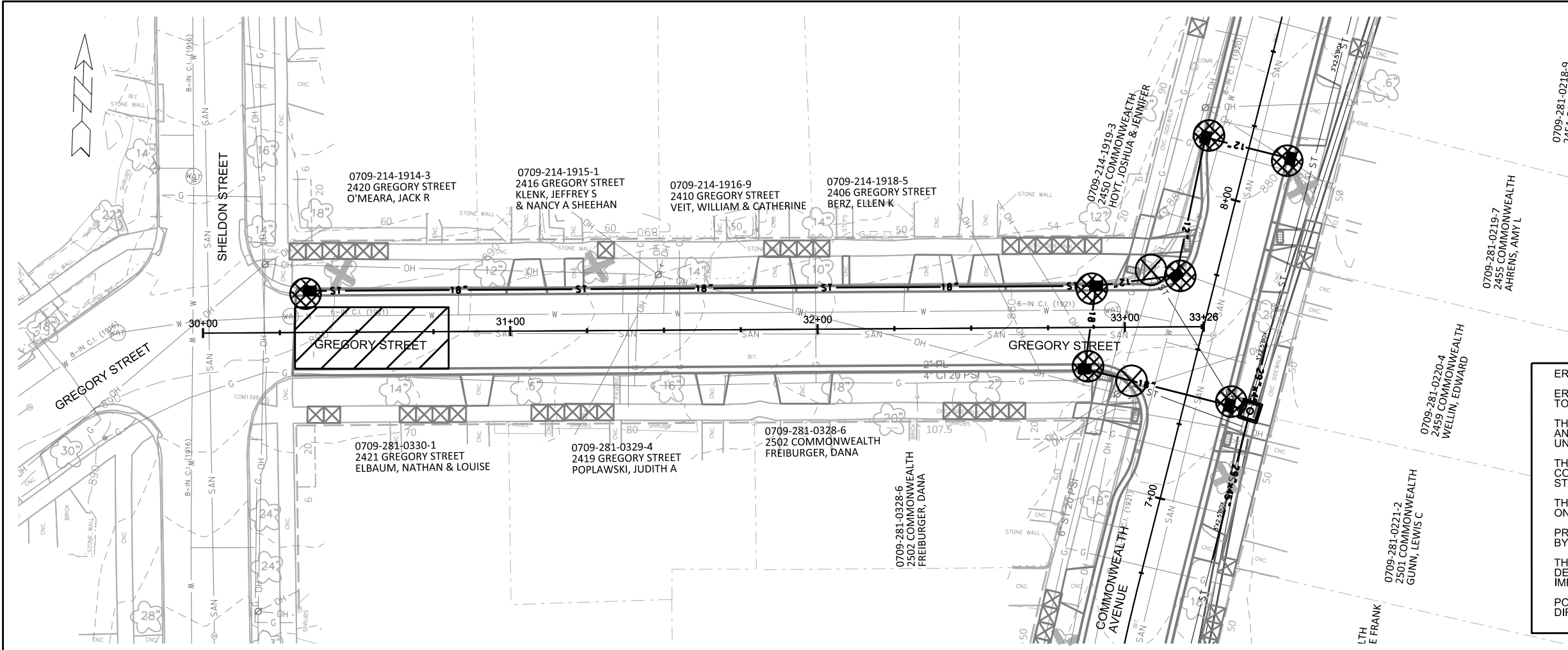

PLOT SCALE: _____

PLOT NAME: _____

REV. DATE: _____

ORIGINATOR: CITY OF MADISON, STREETS DIVISION

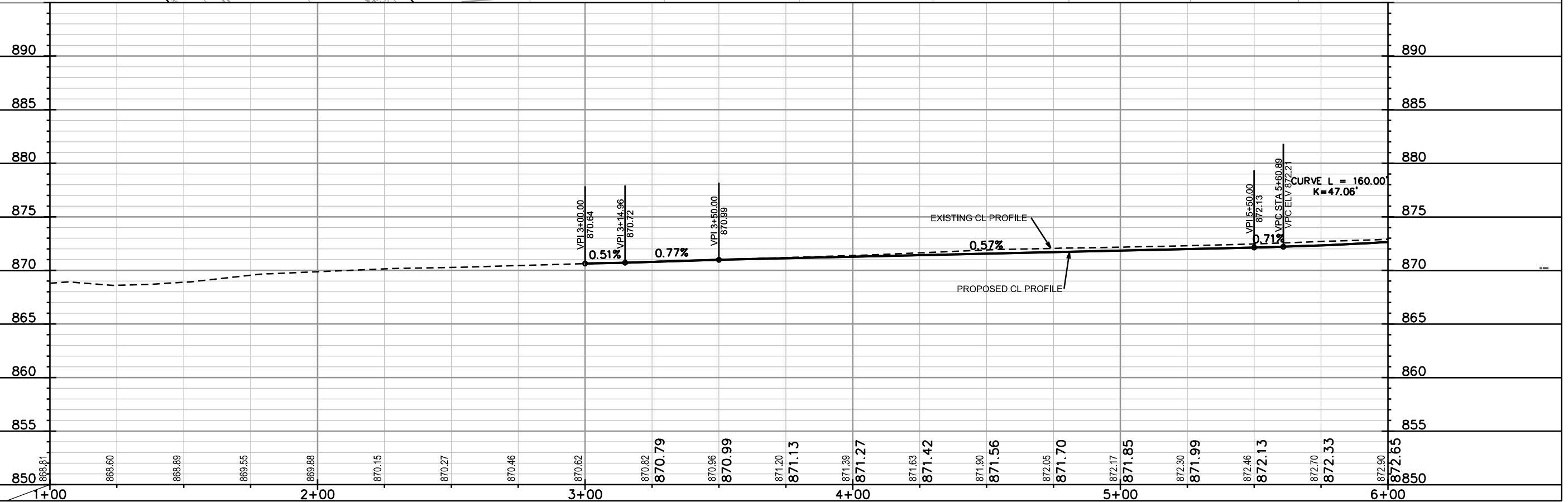
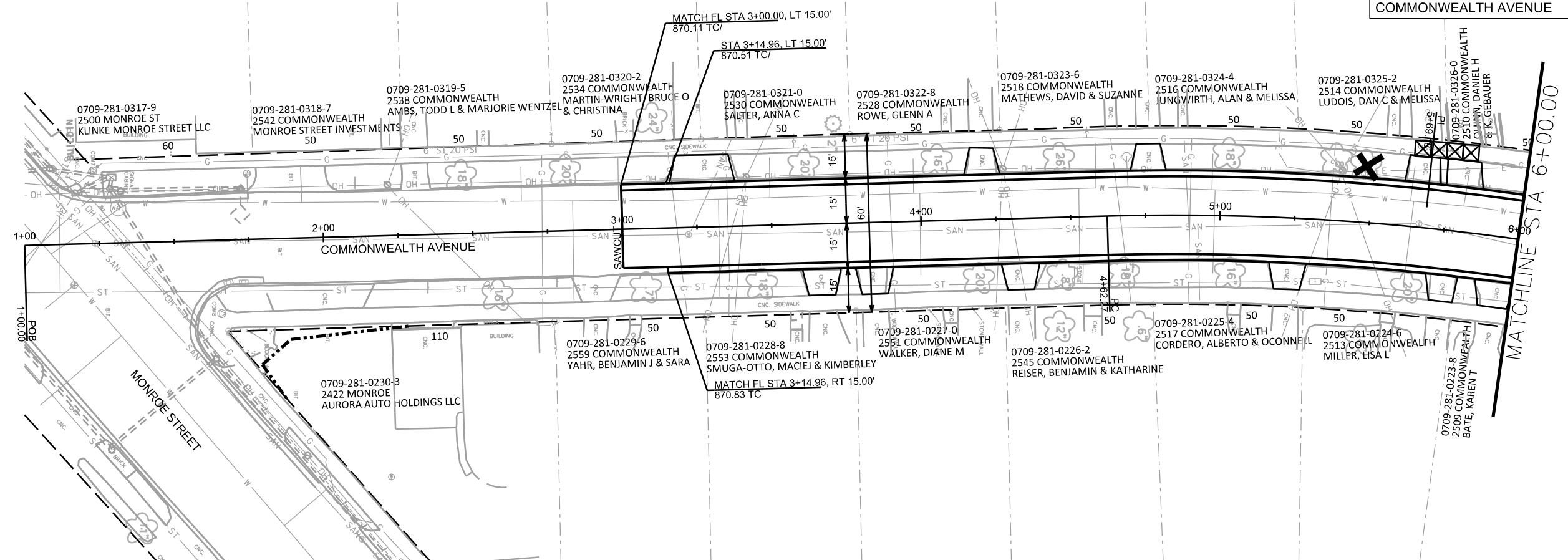

PLOT SCALE: _____

PLOT NAME: _____

REV. DATE: _____

ORIGINATOR: CITY OF MADISON, STREETS DIVISION

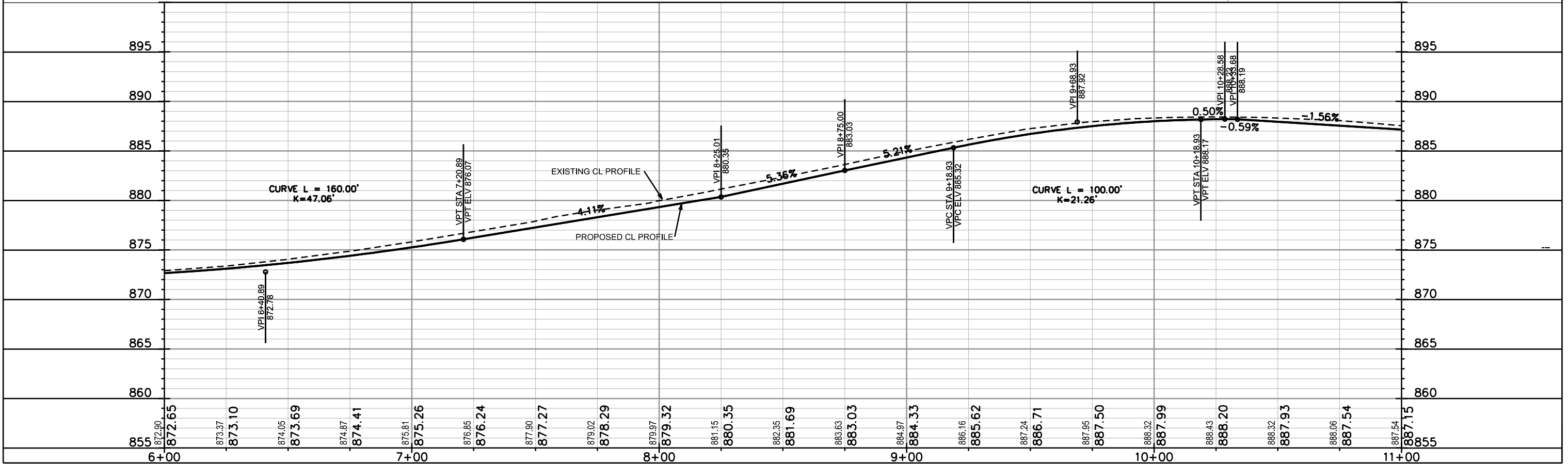
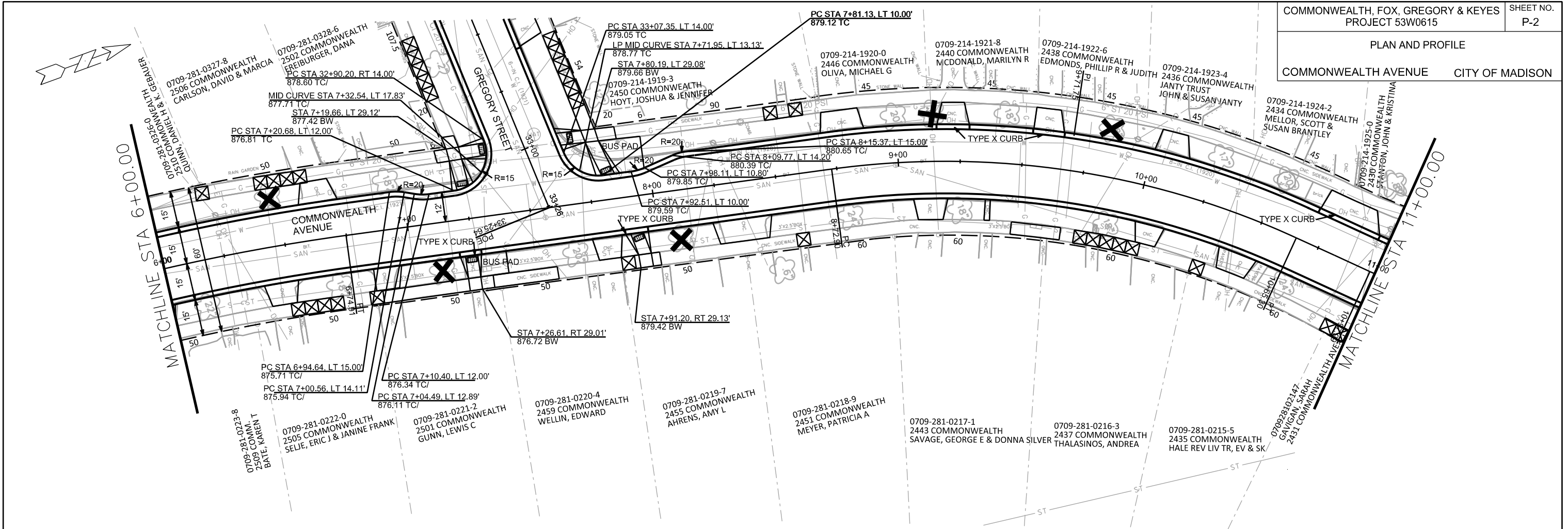

PLOT SCALE: _____

PLOT NAME: _____

REV. DATE: _____

ORIGINATOR: CITY OF MADISON, STREETS DIVISION

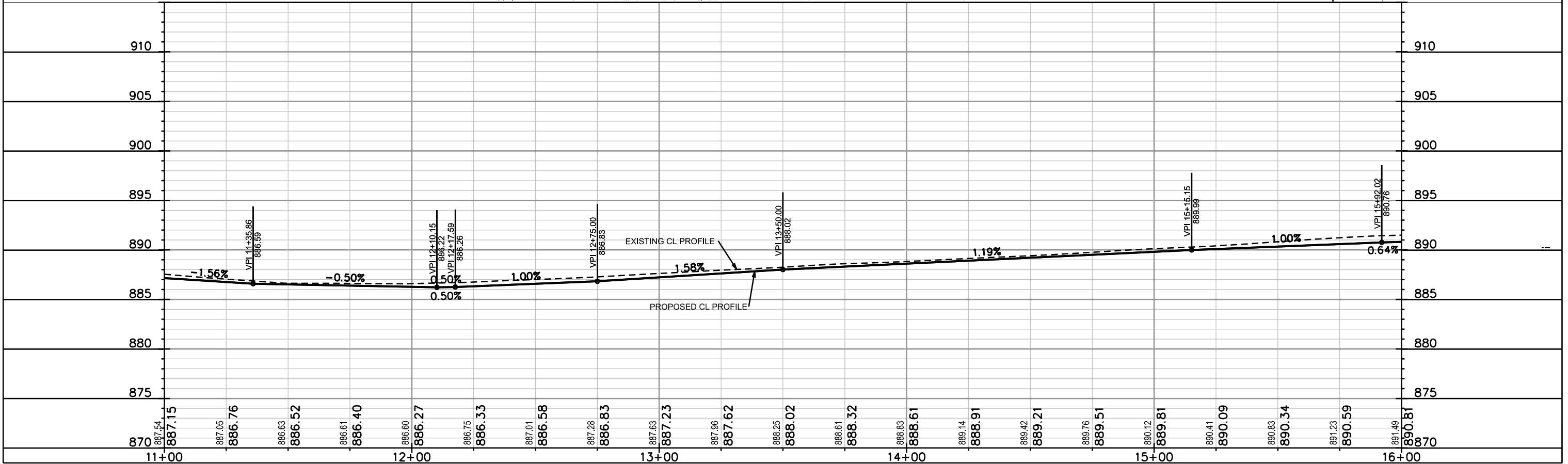
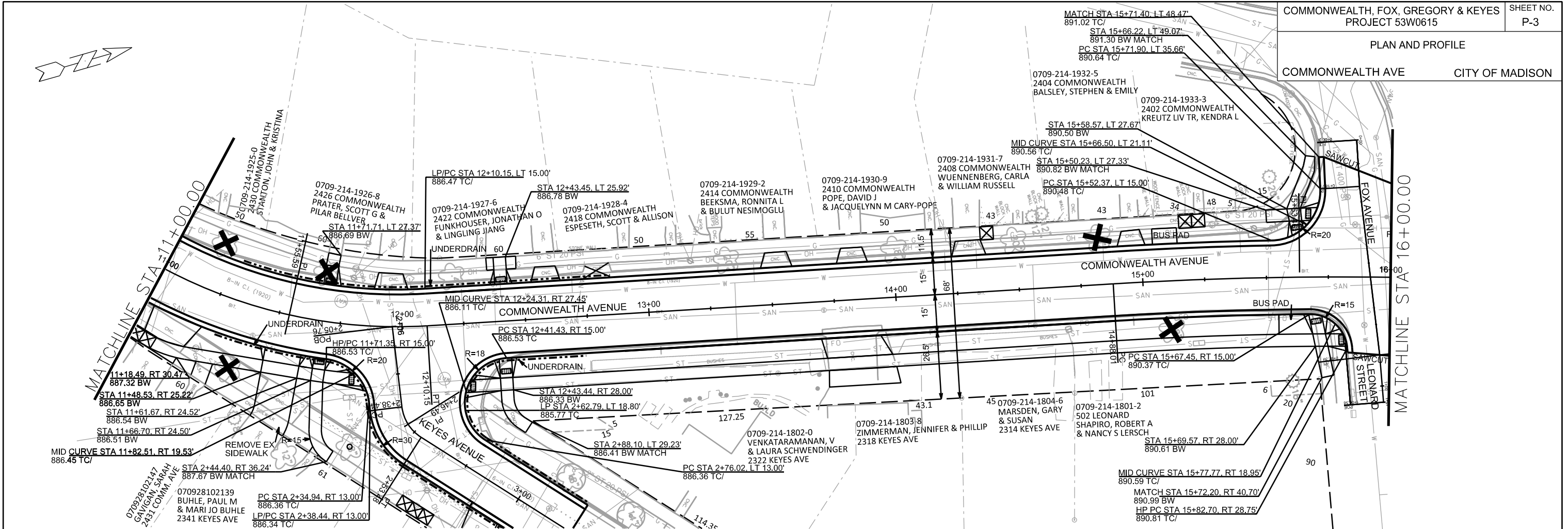

PLOT SCALE: _____

PLOT NAME: _____

REV. DATE: _____

ORIGINATOR: CITY OF MADISON, STREETS DIVISION

PLAN AND PROFILE
COMMONWEALTH AVENUE CITY OF MADISON

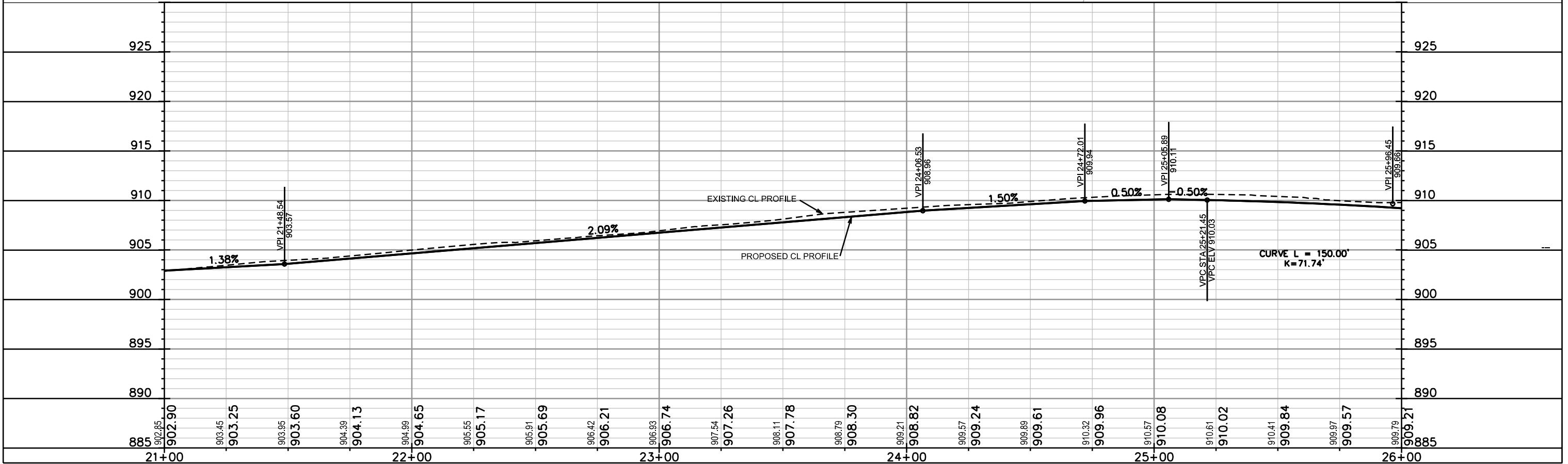
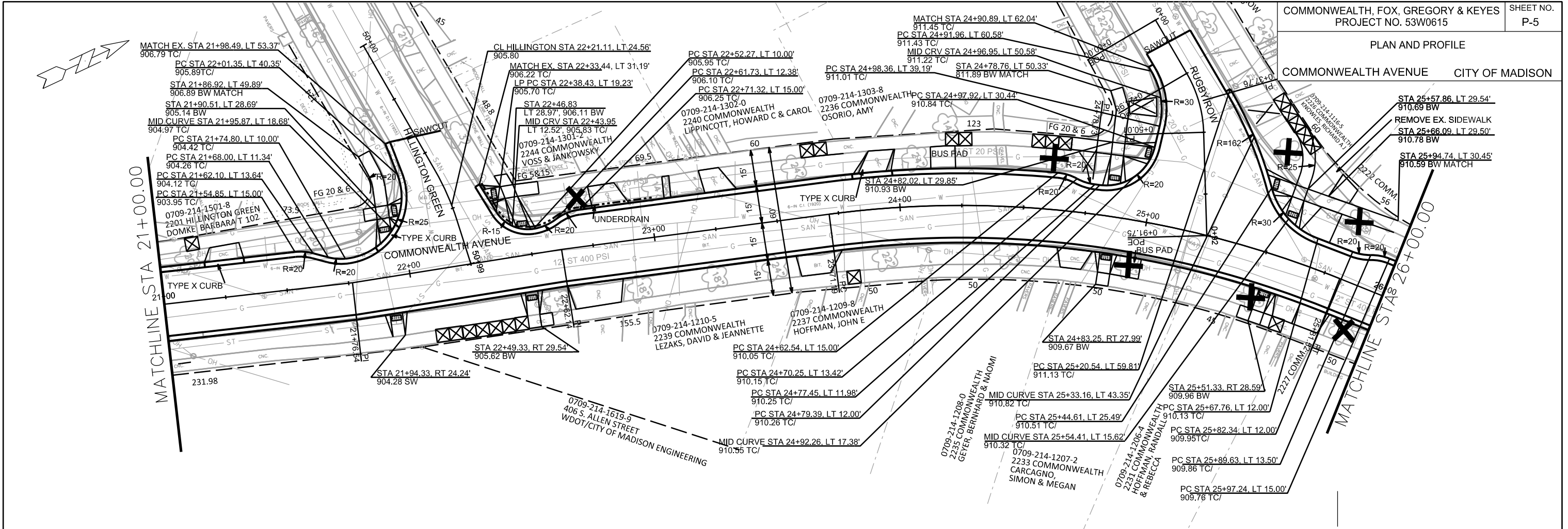

PLOT SCALE: _____

REV. DATE: _____

ORIGINATOR: CITY OF MADISON, STREETS DIVISION

PLAN AND PROFILE
COMMONWEALTH AVENUE CITY OF MADISON

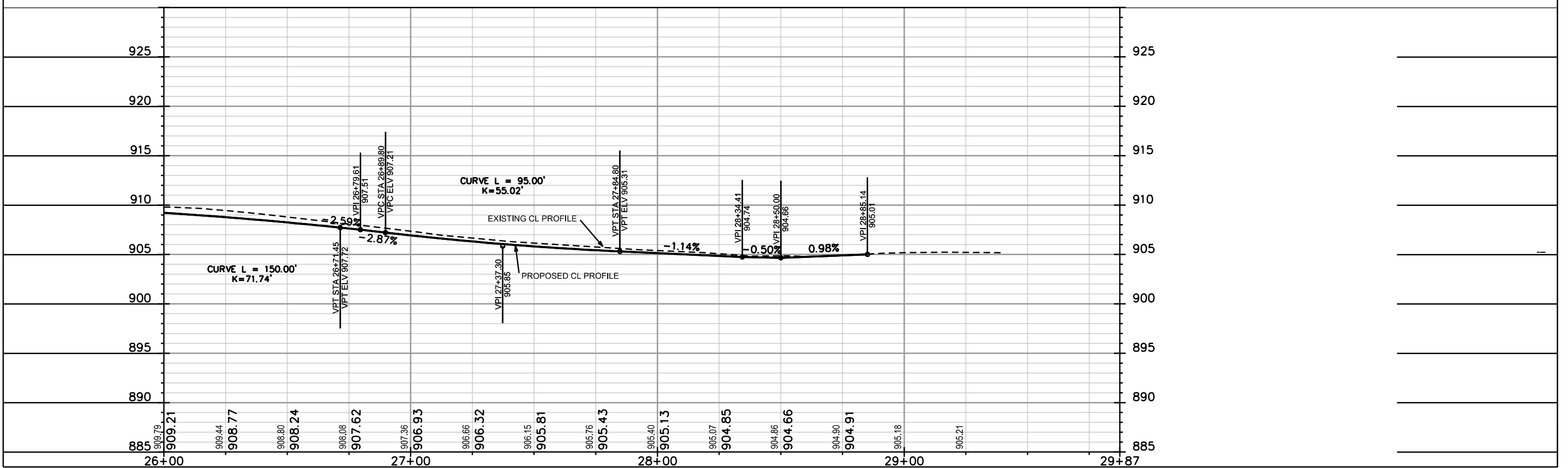
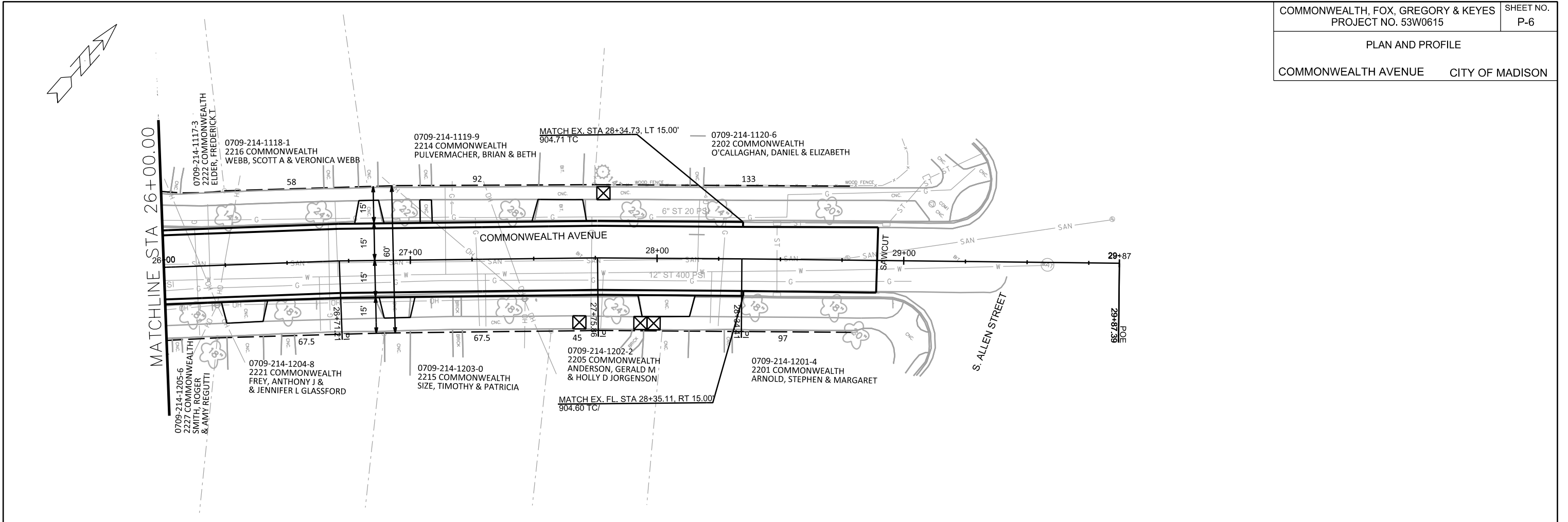

PLOT SCALE: _____

PLOT NAME: _____

REV. DATE: _____

ORIGINATOR: CITY OF MADISON, STREETS DIVISION

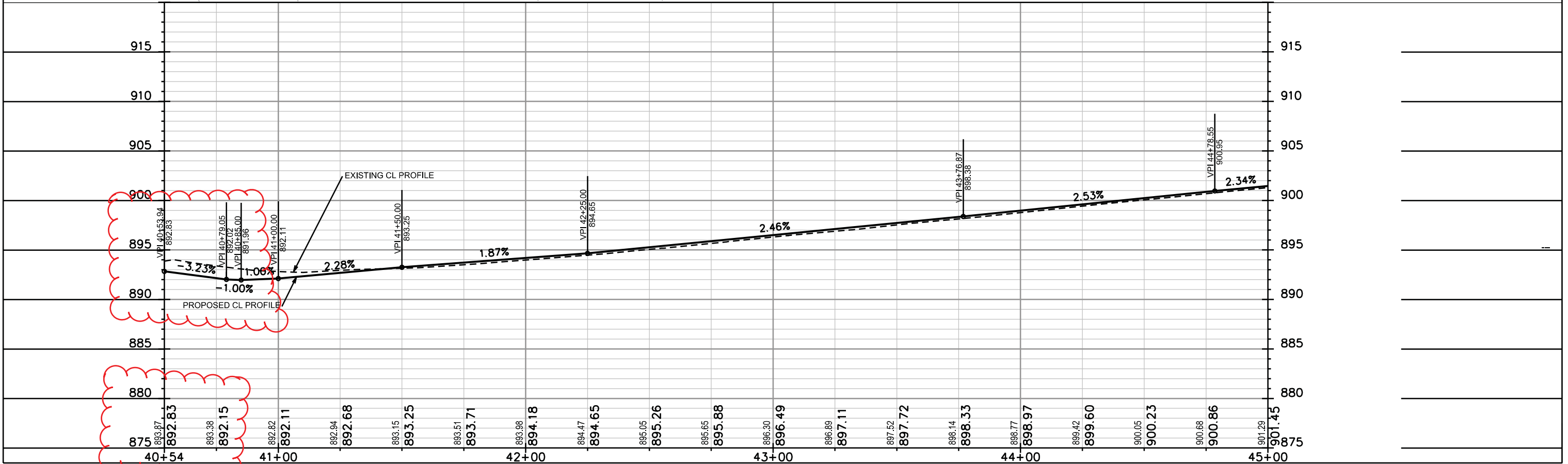
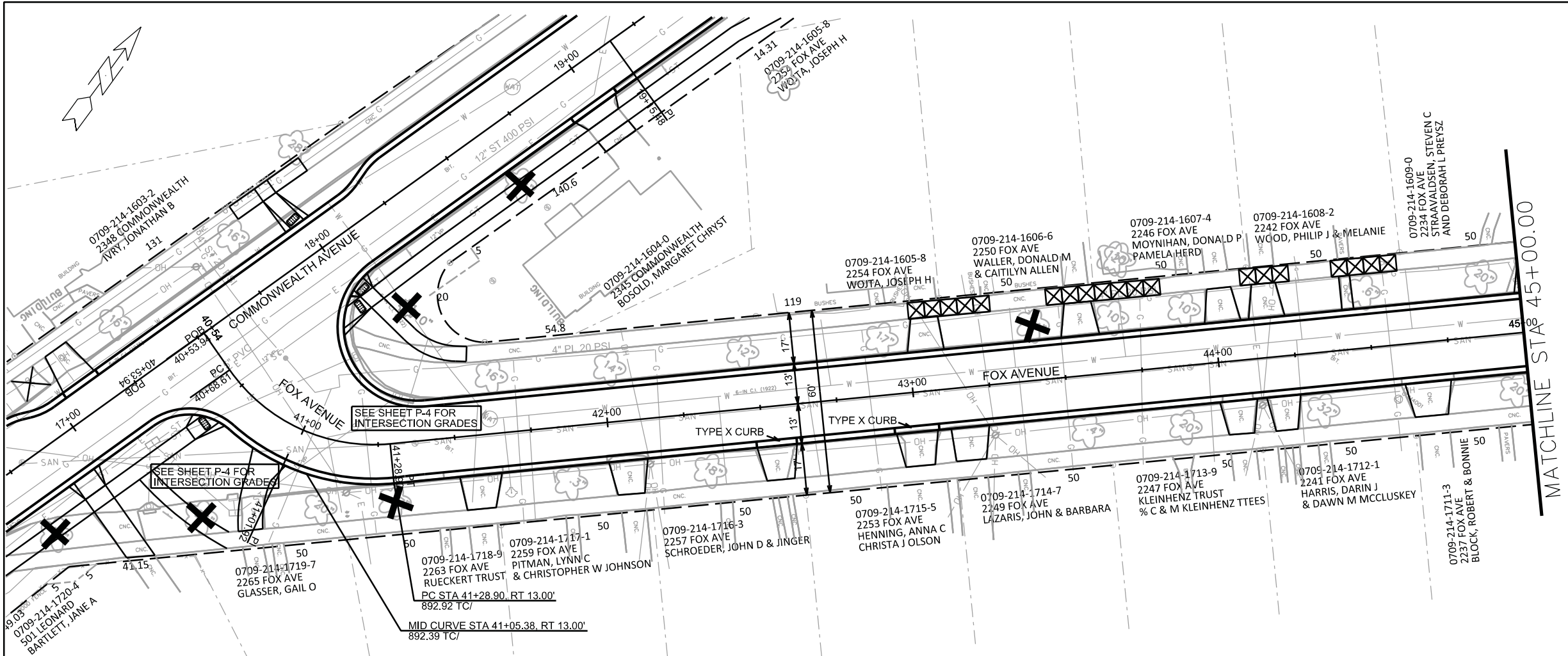

PLOT SCALE: _____

PLOT NAME: _____

REV. DATE: _____

ORIGINATOR: CITY OF MADISON, STREETS DIVISION

PLAN AND PROFILE

FOX AVENUE CITY OF MADISON

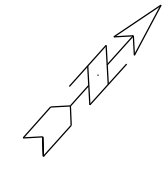

MATCHLINE STA 45+00.00

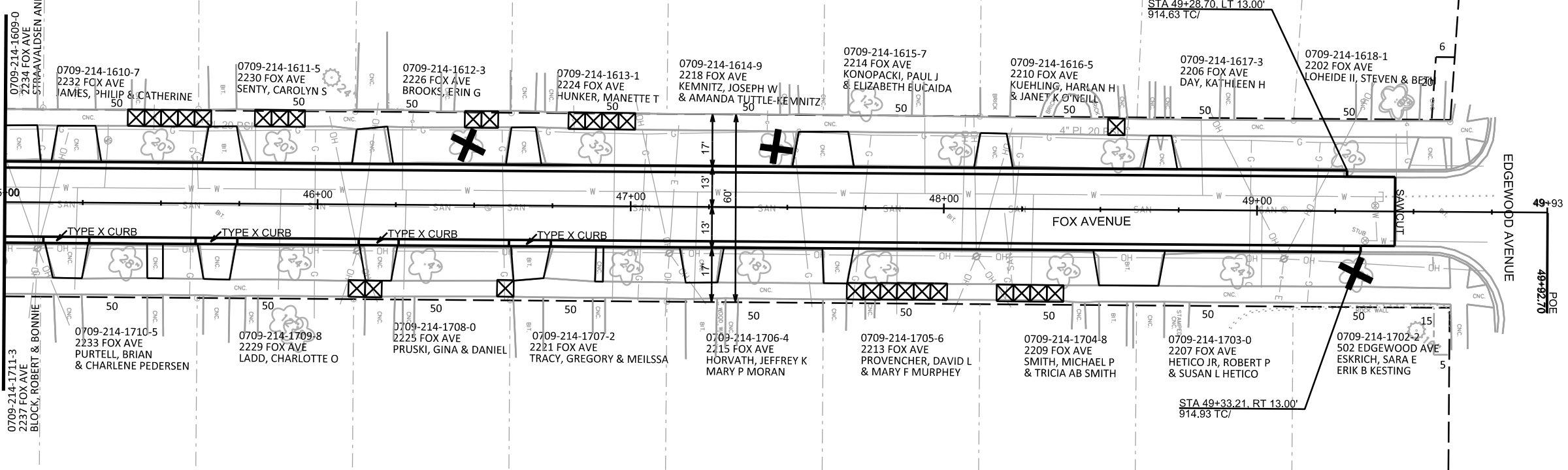

PLOT SCALE: _____

PLOT NAME: _____

REV. DATE: _____

ORIGINATOR: CITY OF MADISON, STREETS DIVISION

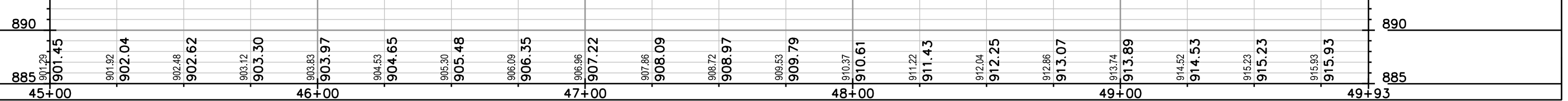

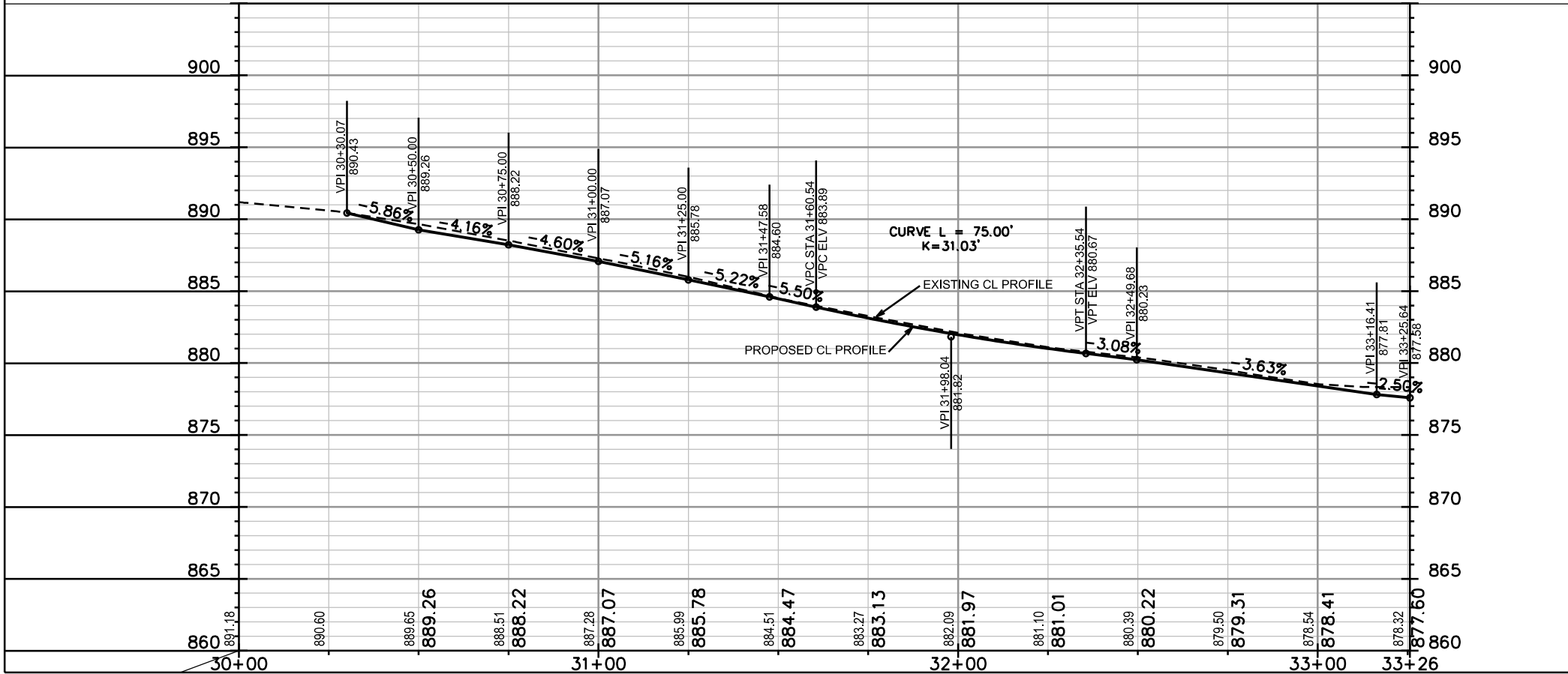
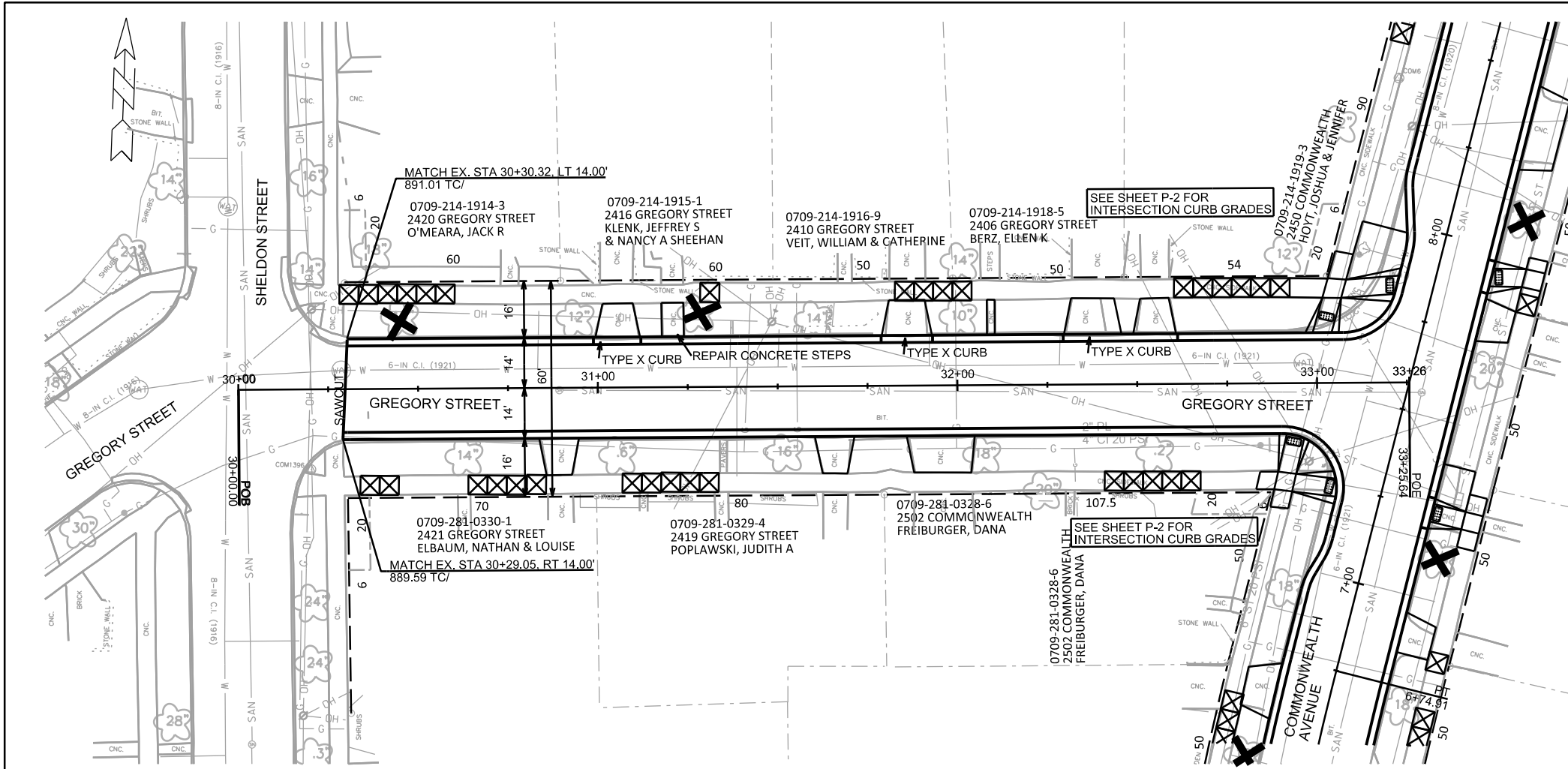

PLOT SCALE: _____

PLOT NAME: _____

REV. DATE: _____

ORIGINATOR: CITY OF MADISON, STREETS DIVISION

PLAN AND PROFILE

KEYES AVENUE

CITY OF MADISON

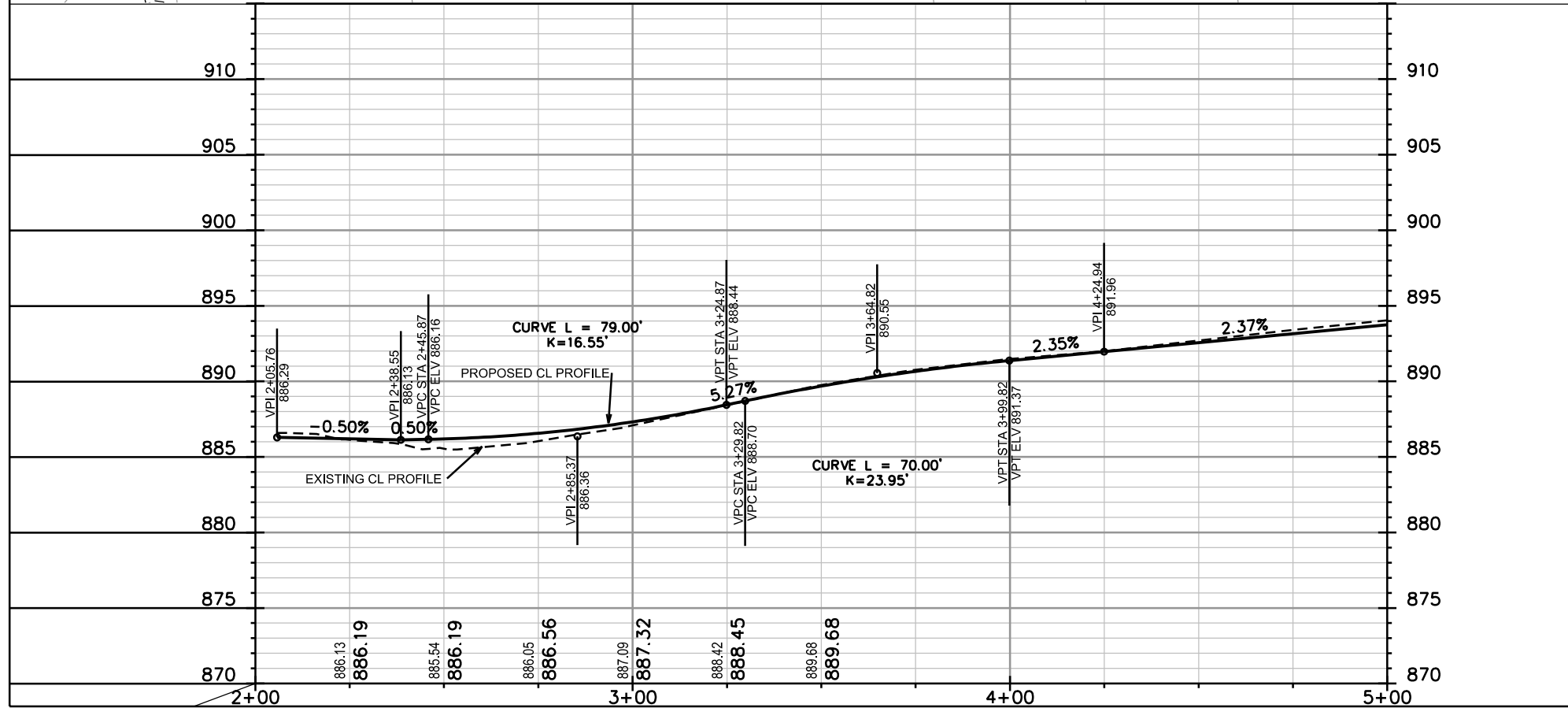
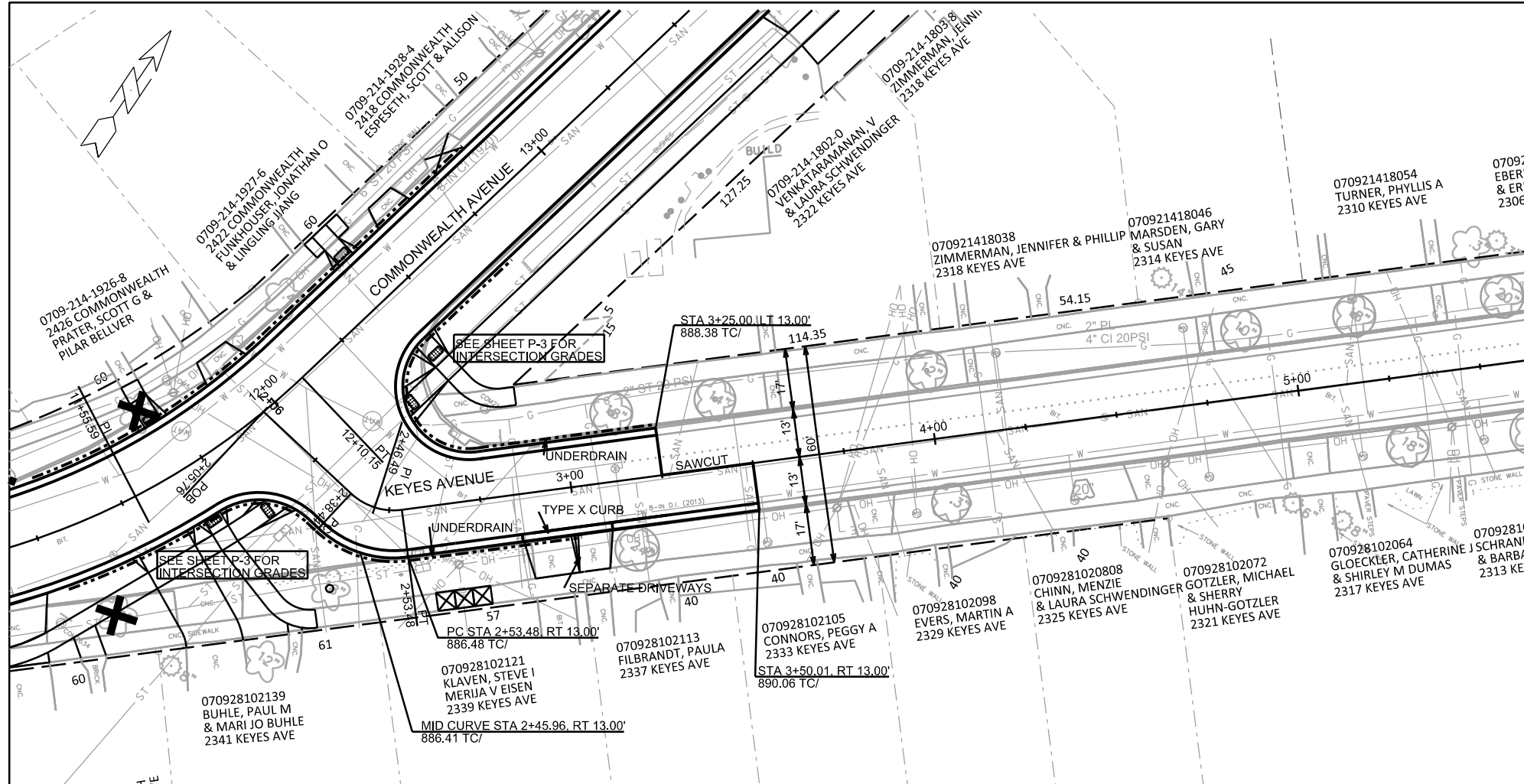

PLOT SCALE: _____

PLOT NAME: _____

REV. DATE: _____

ORIGINATOR: CITY OF MADISON, STREETS DIVISION



CONTRACTOR SHALL REM & REP
SIDEWALK AS NEEDED FOR LATERALS
(MAX. OF 4 SW SQUARES PER LATERAL)

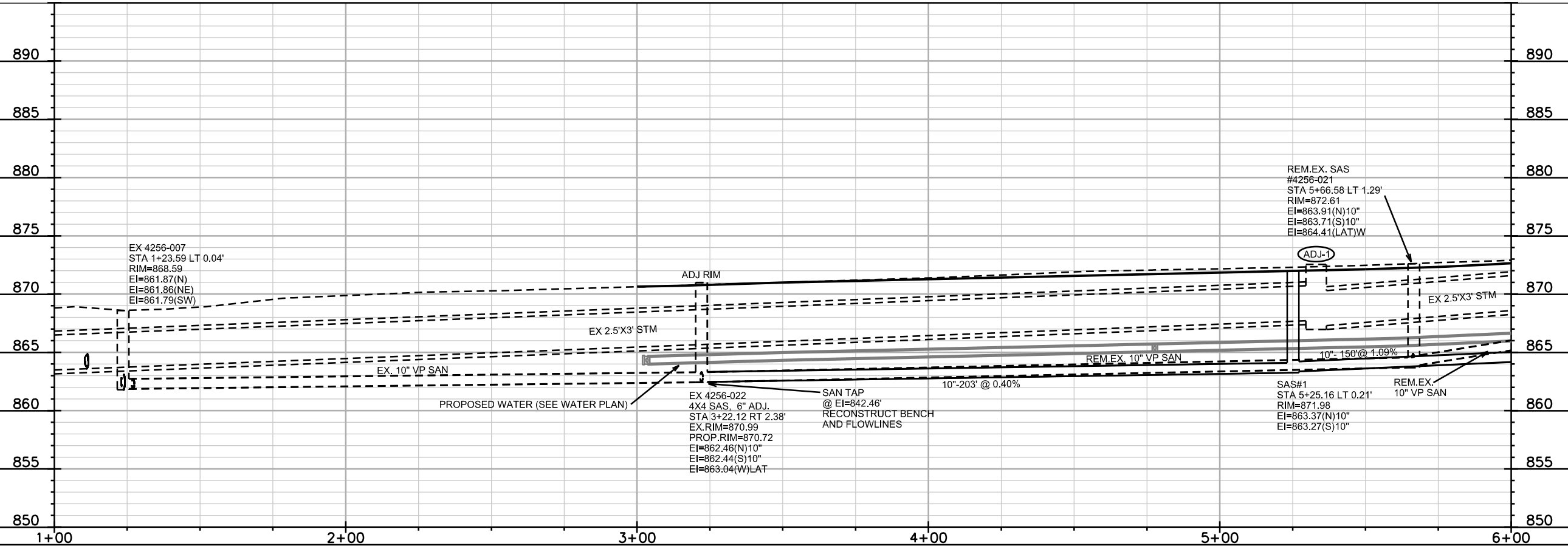
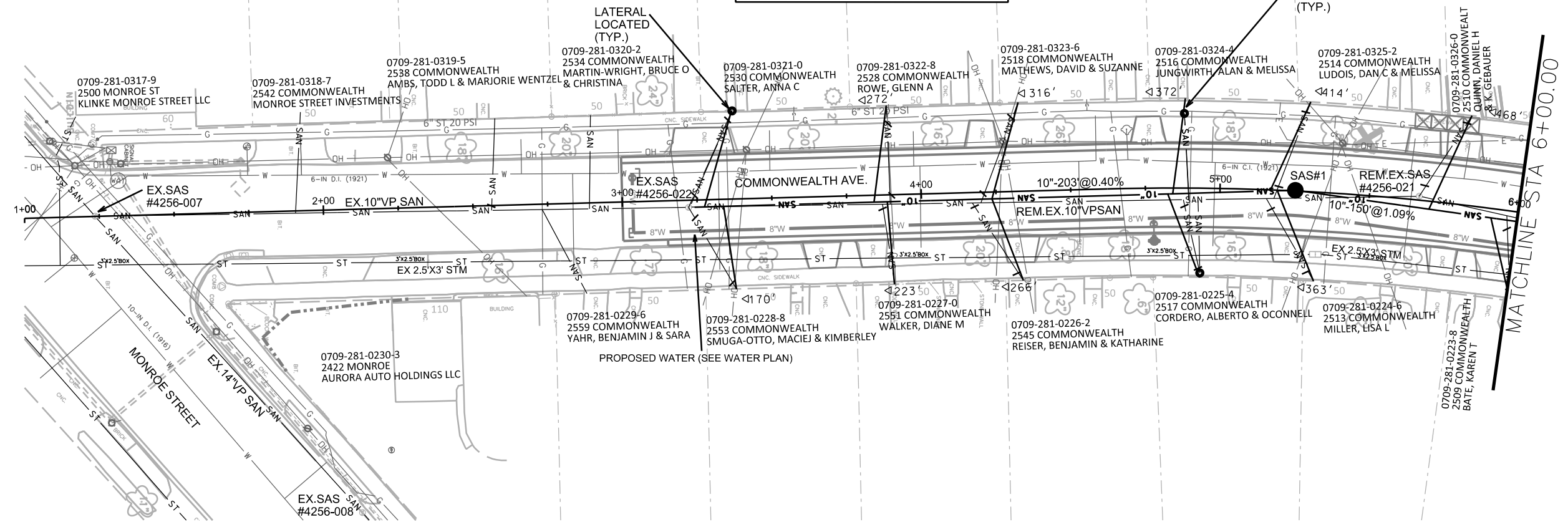

PLOT SCALE: _____

PLOT NAME: _____

REV. DATE: _____

ORIGINATOR: CITY OF MADISON, STREETS DIVISION

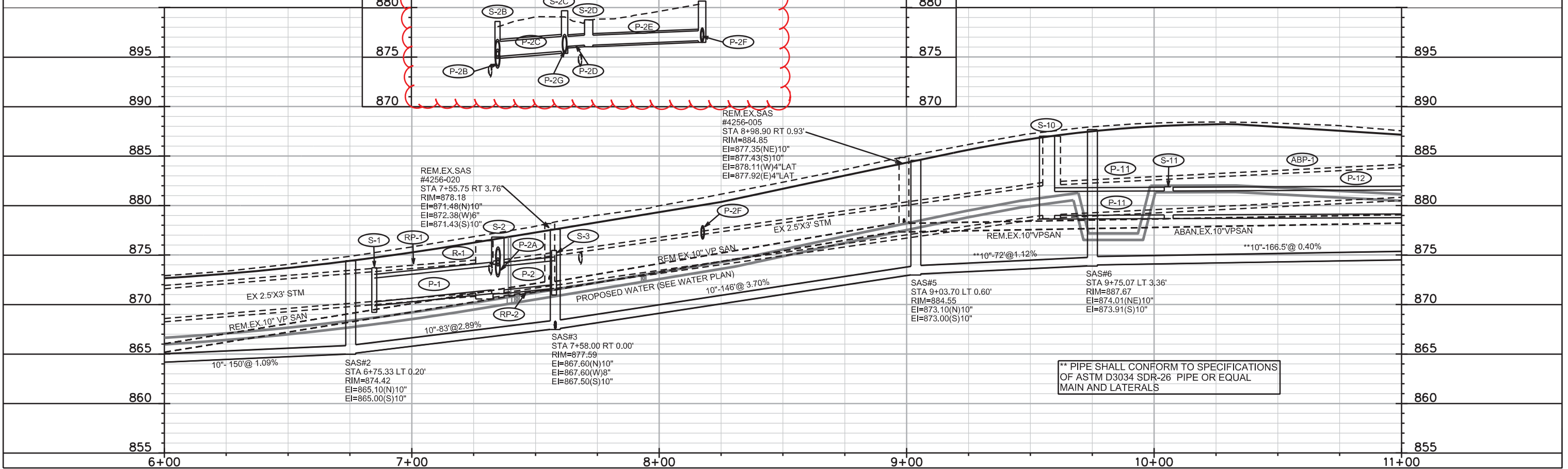
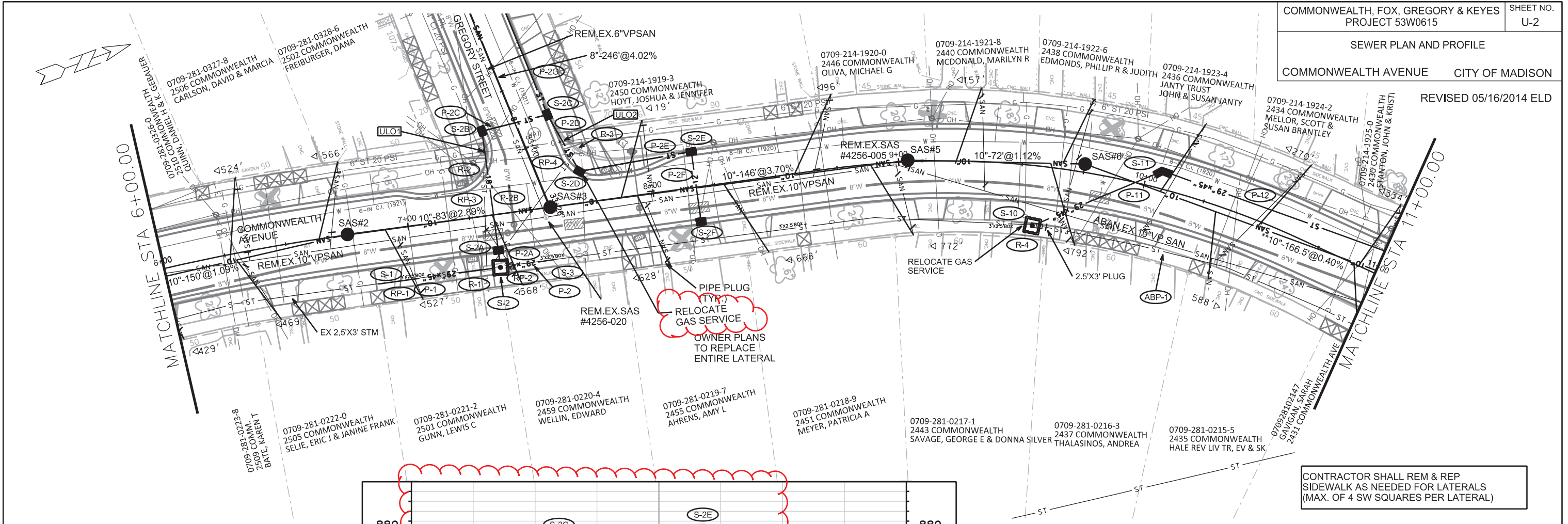

PLOT SCALE: _____

PLOT NAME: _____

REV. DATE: _____

ORIGINATOR: CITY OF MADISON, STREETS DIVISION

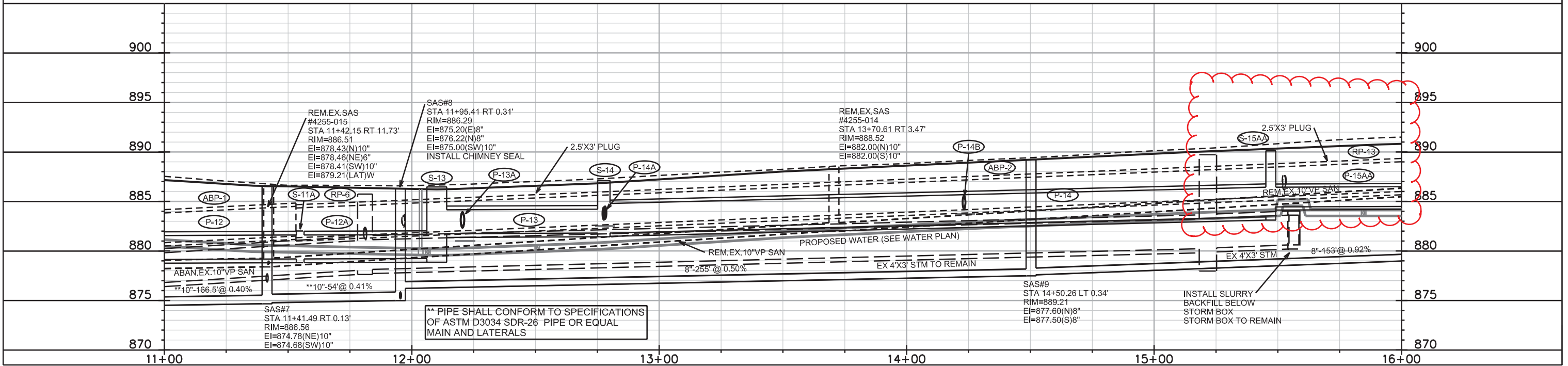
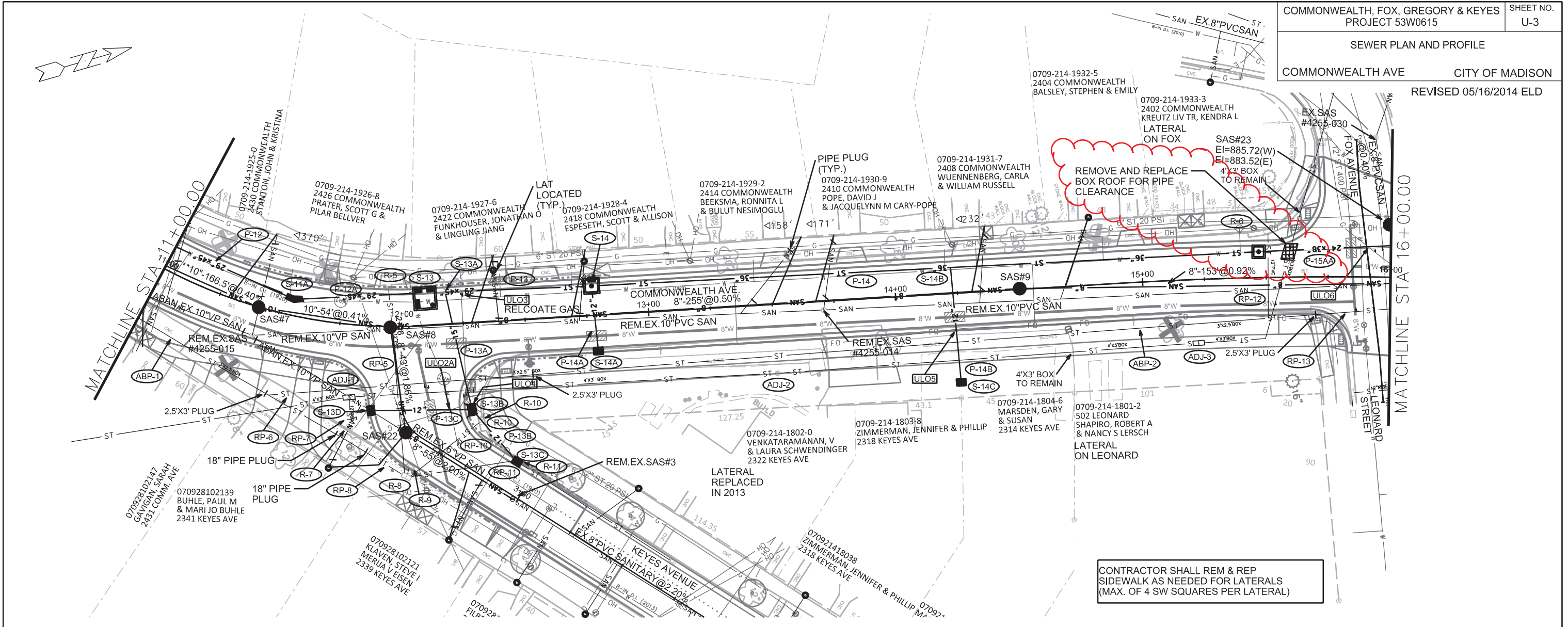

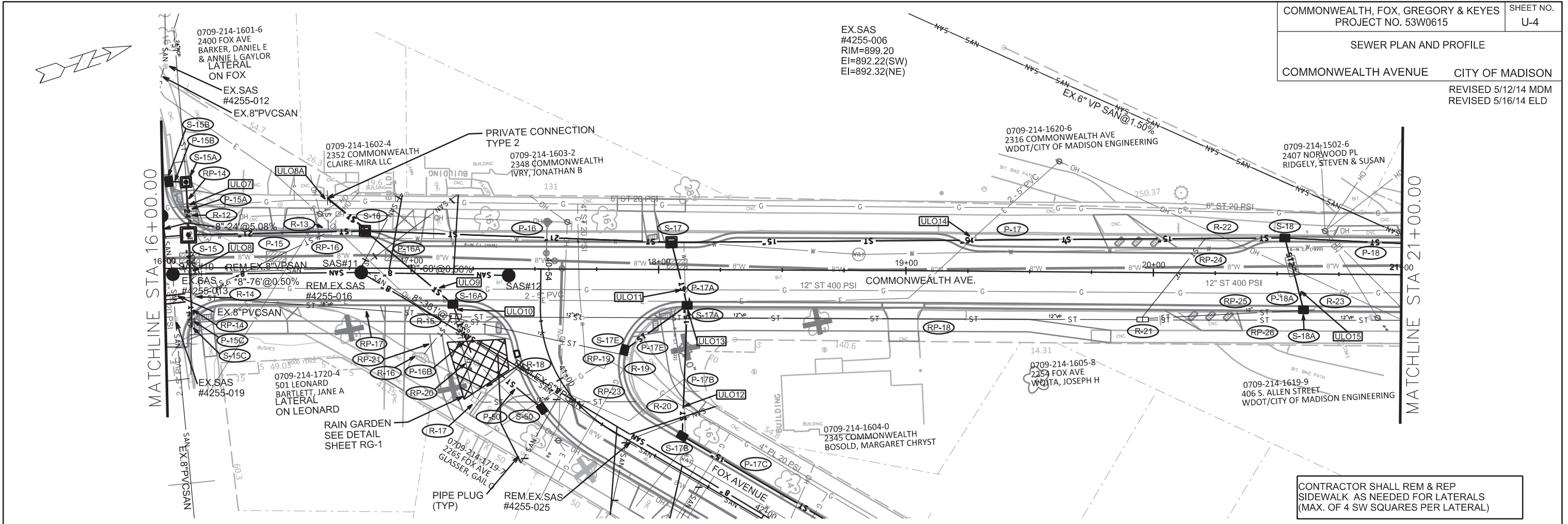

CONTRACTOR SHALL REM & REP
SIDEWALK AS NEEDED FOR LATERALS
(MAX. OF 4 SW SQUARES PER LATERAL)

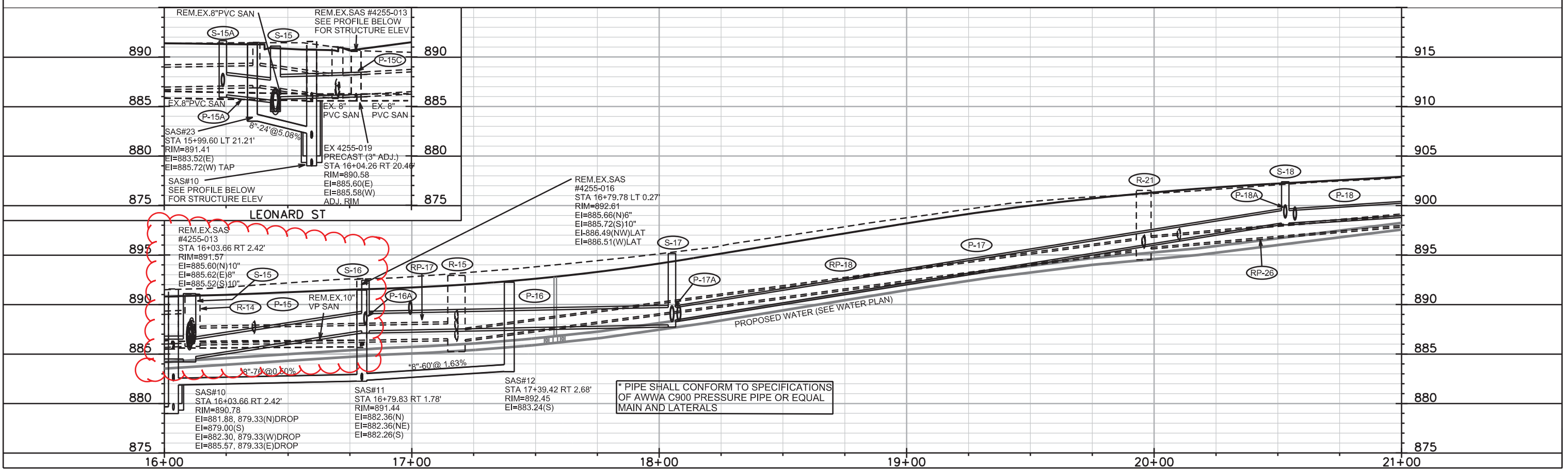

* PIPE SHALL CONFORM TO SPECIFICATIONS
OF AWWA C900 PRESSURE PIPE OR EQUAL
MAIN AND LATERALS

PLOT SCALE: _____

REV. DATE: _____

ORIGINATOR: CITY OF MADISON, STREETS DIVISION

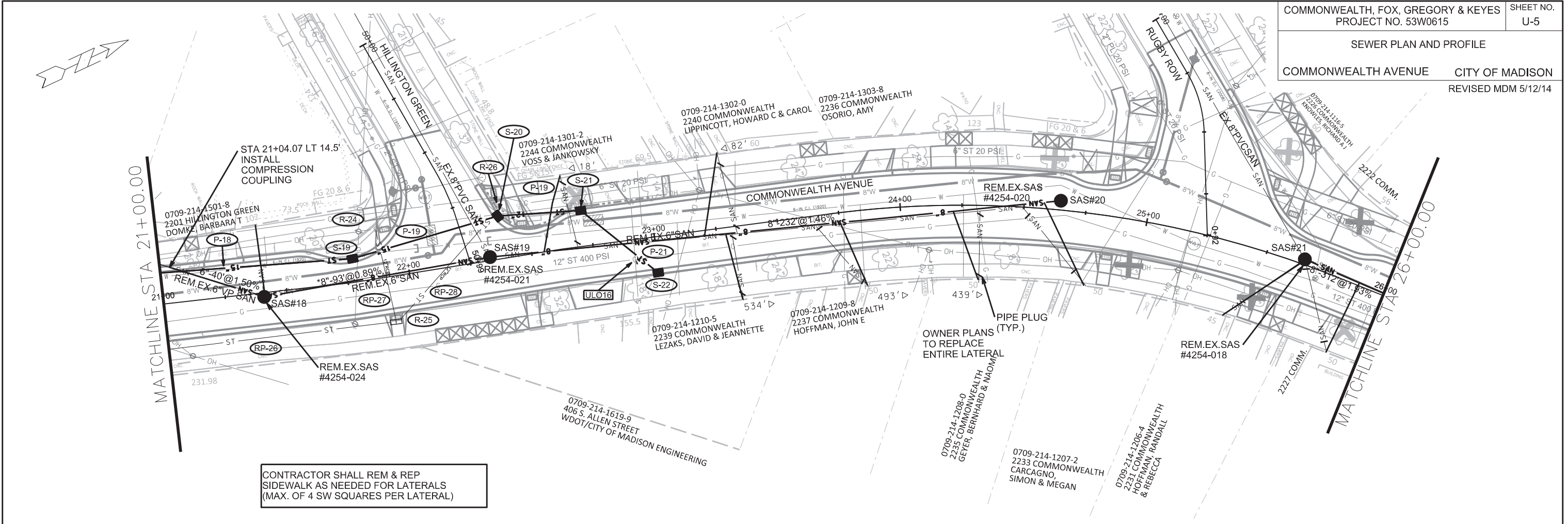

CONTRACTOR SHALL REM & REP SIDEWALK AS NEEDED FOR LATERALS (MAX. OF 4 SW SQUARES PER LATERAL)

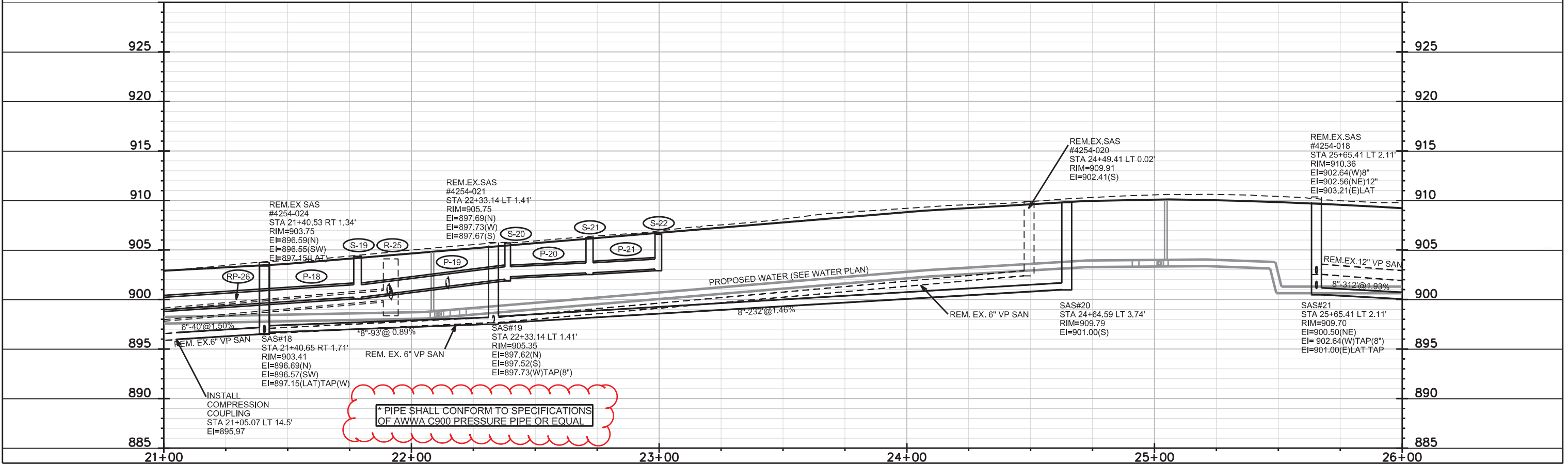

* PIPE SHALL CONFORM TO SPECIFICATIONS OF AWWA C900 PRESSURE PIPE OR EQUAL

PLOT SCALE: _____
REV. DATE: _____
ORIGINATOR: CITY OF MADISON, STREETS DIVISION

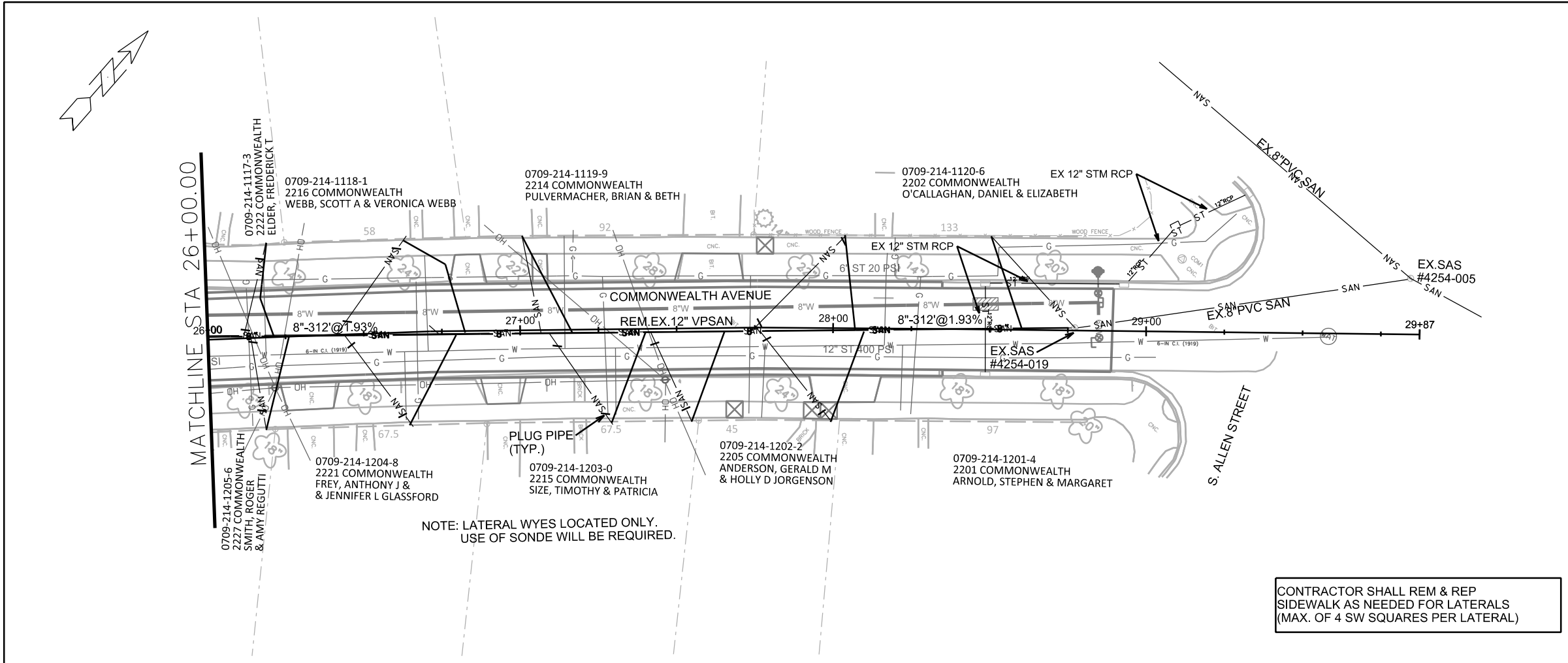

NOTE: LATERAL WYES LOCATED ONLY.
USE OF SONDE WILL BE REQUIRED.

CONTRACTOR SHALL REM & REP
SIDEWALK AS NEEDED FOR LATERALS
(MAX. OF 4 SW SQUARES PER LATERAL)

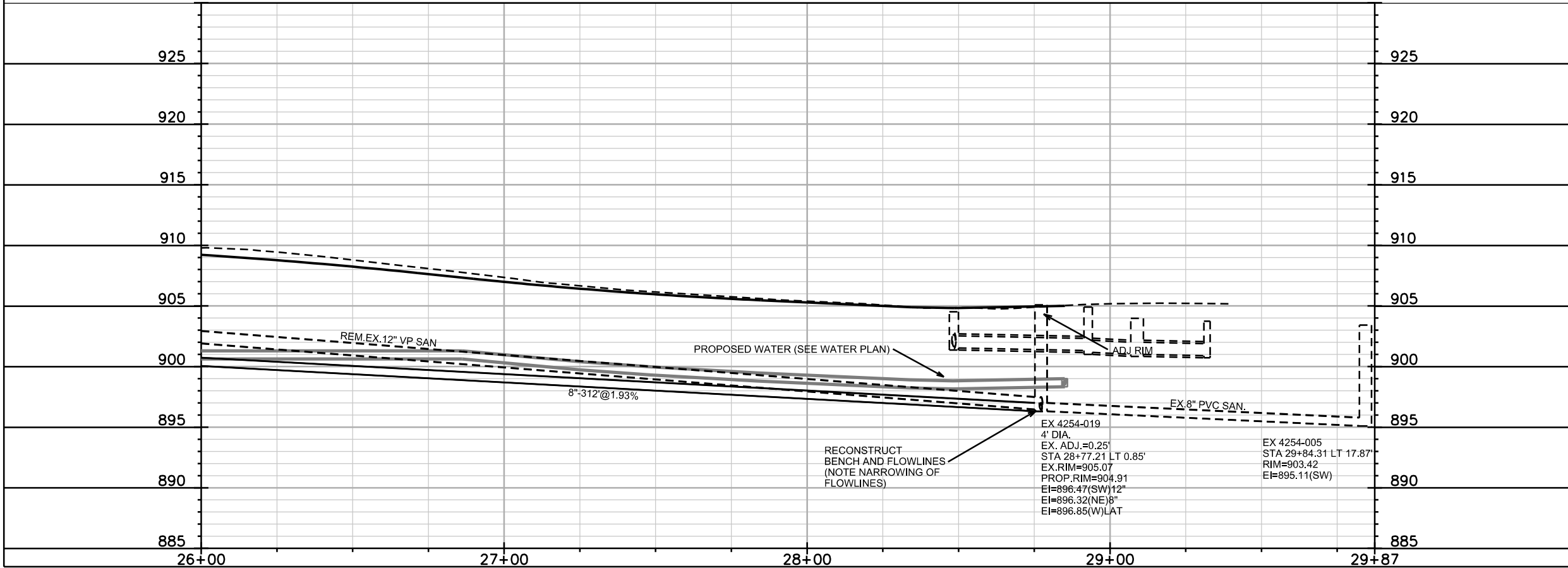

RECONSTRUCT
BENCH AND FLOWLINES
(NOTE NARROWING OF
FLOWLINES)

EX 4254-019
4' DIA.
EX. ADJ = 0.25'
STA 28+77.21 LT 0.85'
EX RIM = 905.07
PROP. RIM = 904.91
EI = 896.47 (SW) 12"
EI = 896.32 (NE) 8"
EI = 896.85 (W) LAT

EX 4254-005
STA 29+84.31 LT 17.87'
RIM = 903.42
EI = 895.11 (SW)

PLOT SCALE: _____

PLOT NAME: _____

REV. DATE: _____

ORIGINATOR: CITY OF MADISON, STREETS DIVISION

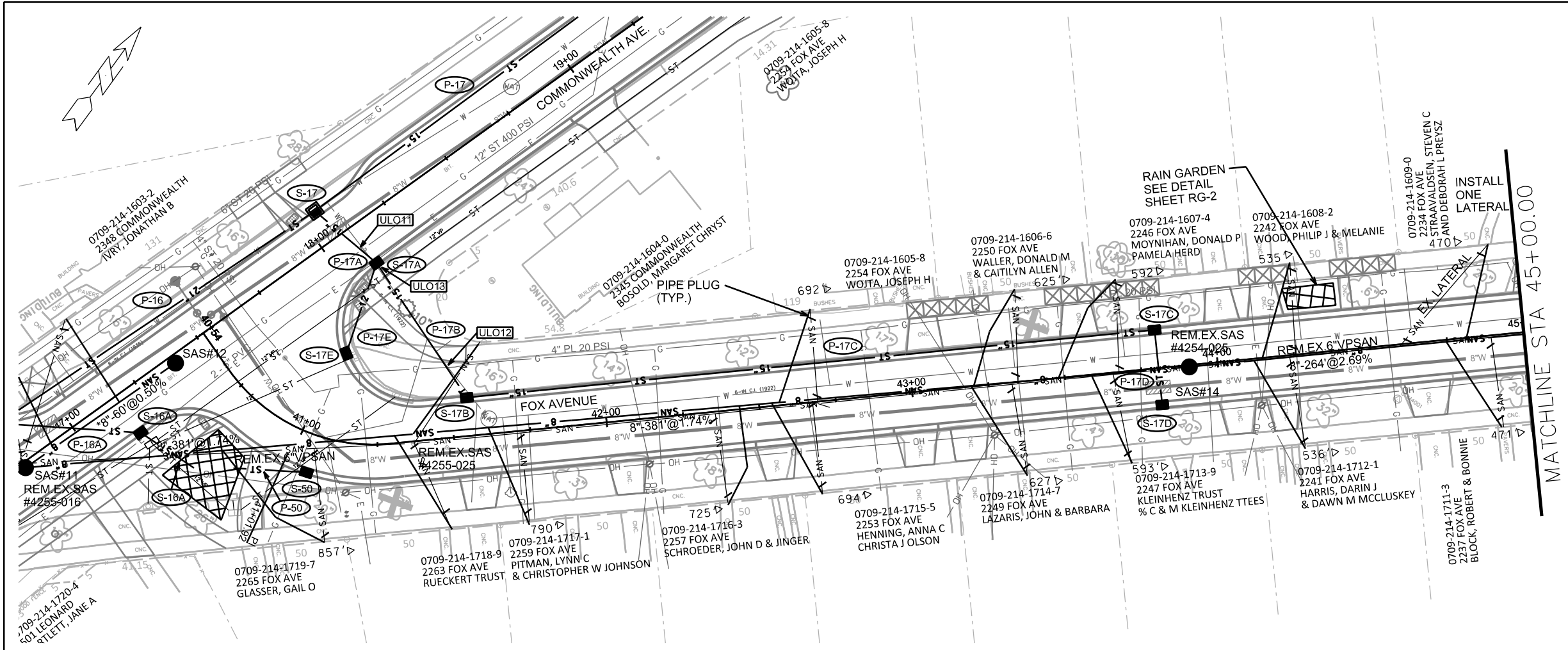

CONTRACTOR SHALL REM & REP
SIDEWALK AS NEEDED FOR LATERALS
(MAX. OF 4 SW SQUARES PER LATERAL)

STORM STRUCTURES AND PIPE
REMOVALS SHOWN ON SHEET U-4

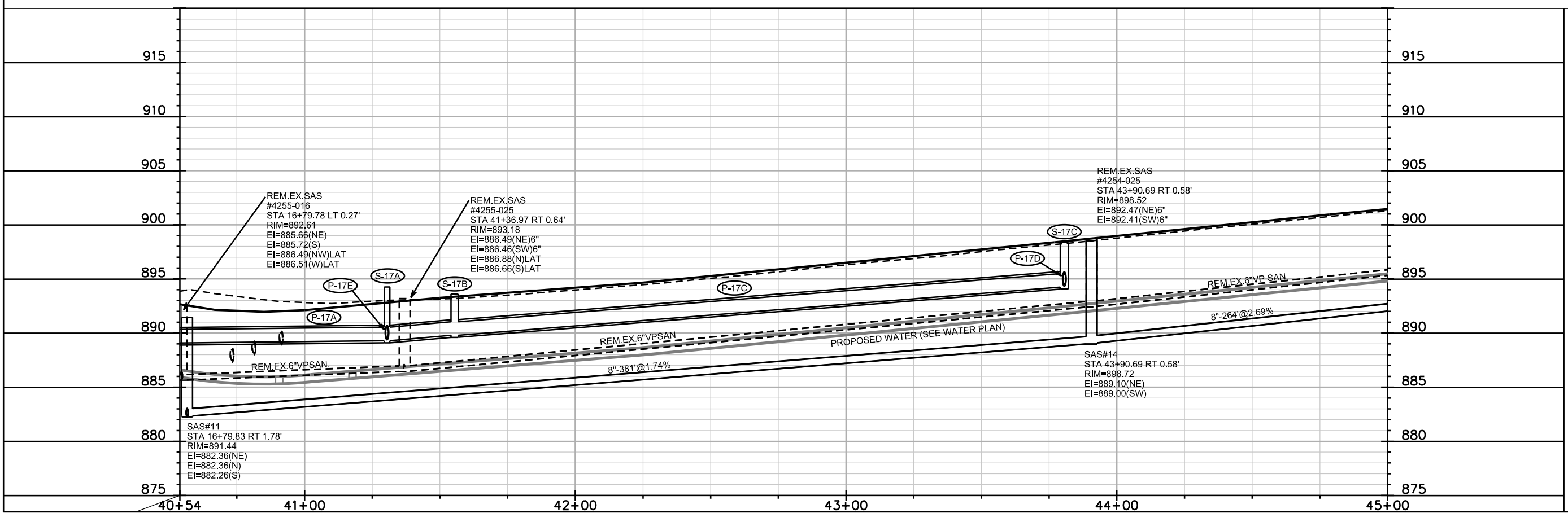

PLOT SCALE: _____

REV. DATE: _____

ORIGINATOR: CITY OF MADISON, STREETS DIVISION

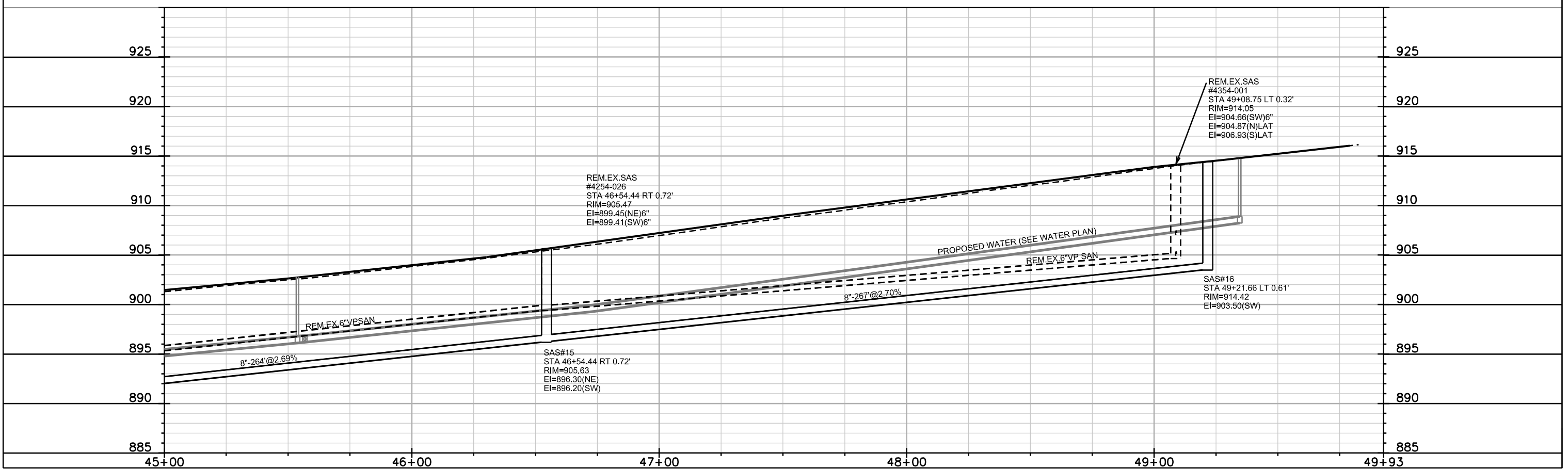
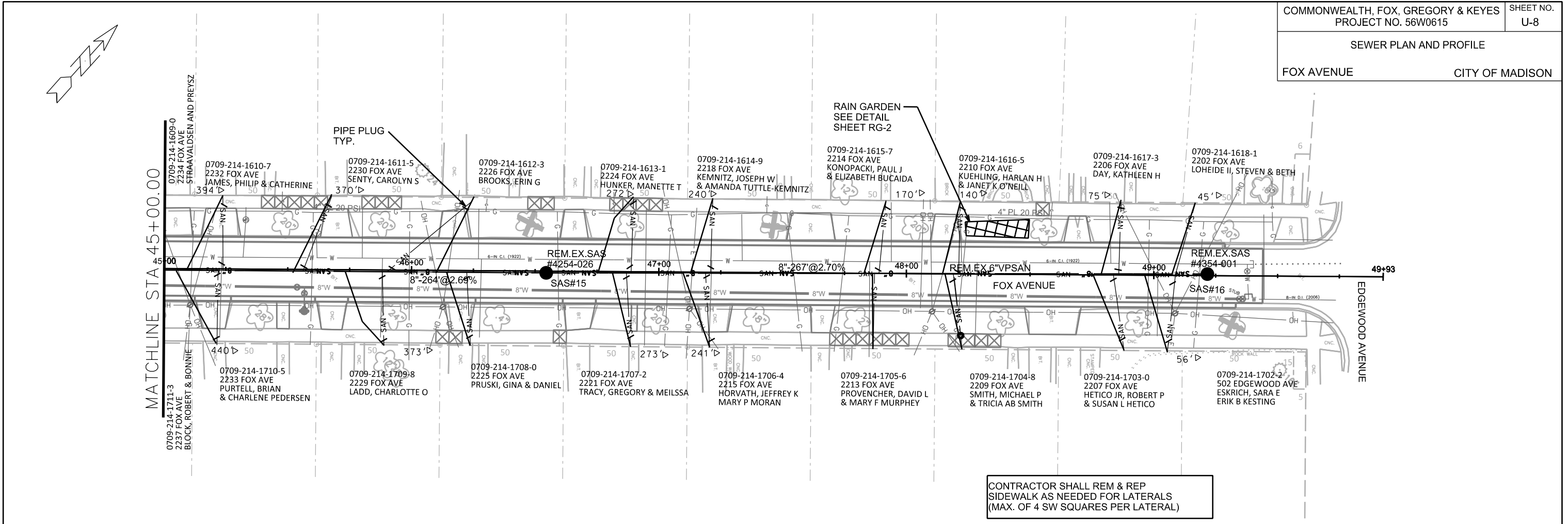

PLOT SCALE: _____

PLOT NAME: _____

REV. DATE: _____

ORIGINATOR: CITY OF MADISON, STREETS DIVISION

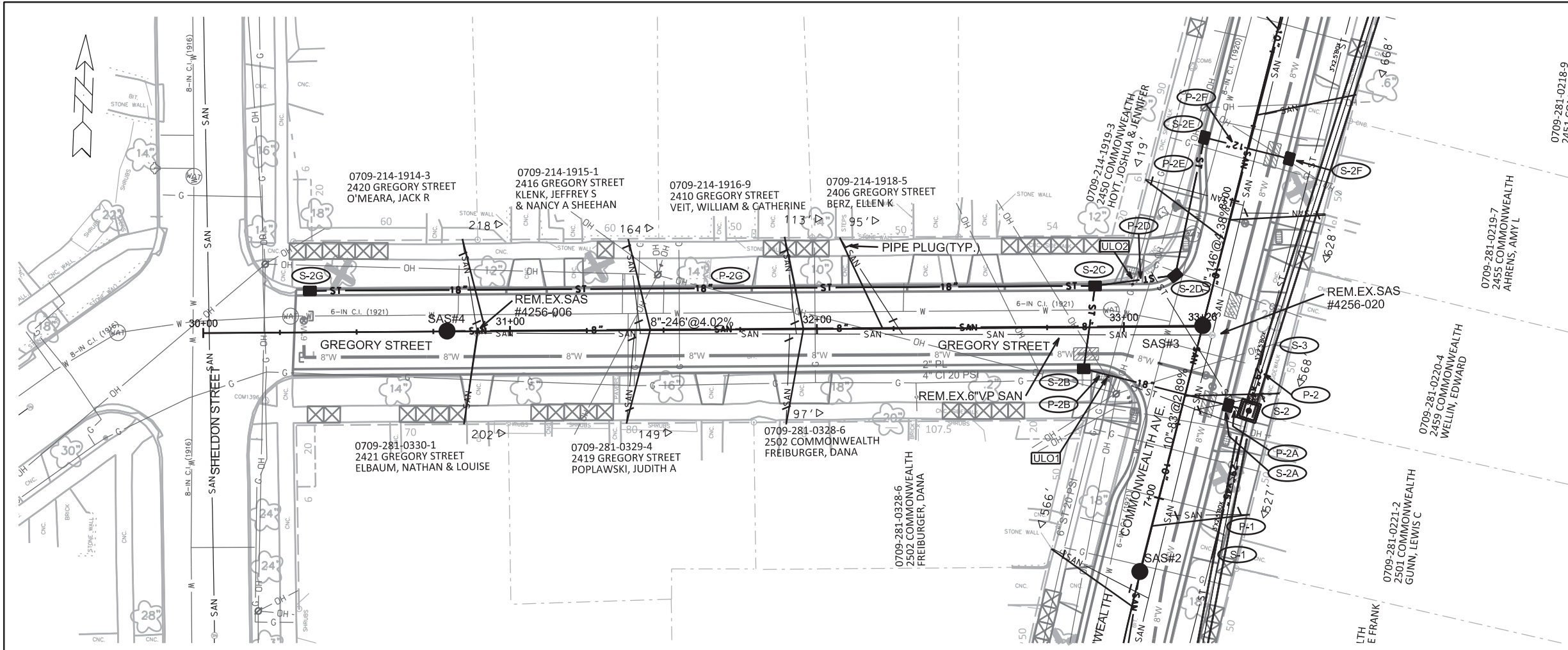

STORM STRUCTURES AND PIPE REMOVALS SHOWN ON SHEET U-2

CONTRACTOR SHALL REM & REP SIDEWALK AS NEEDED FOR LATERALS (MAX. OF 4 SW SQUARES PER LATERAL)

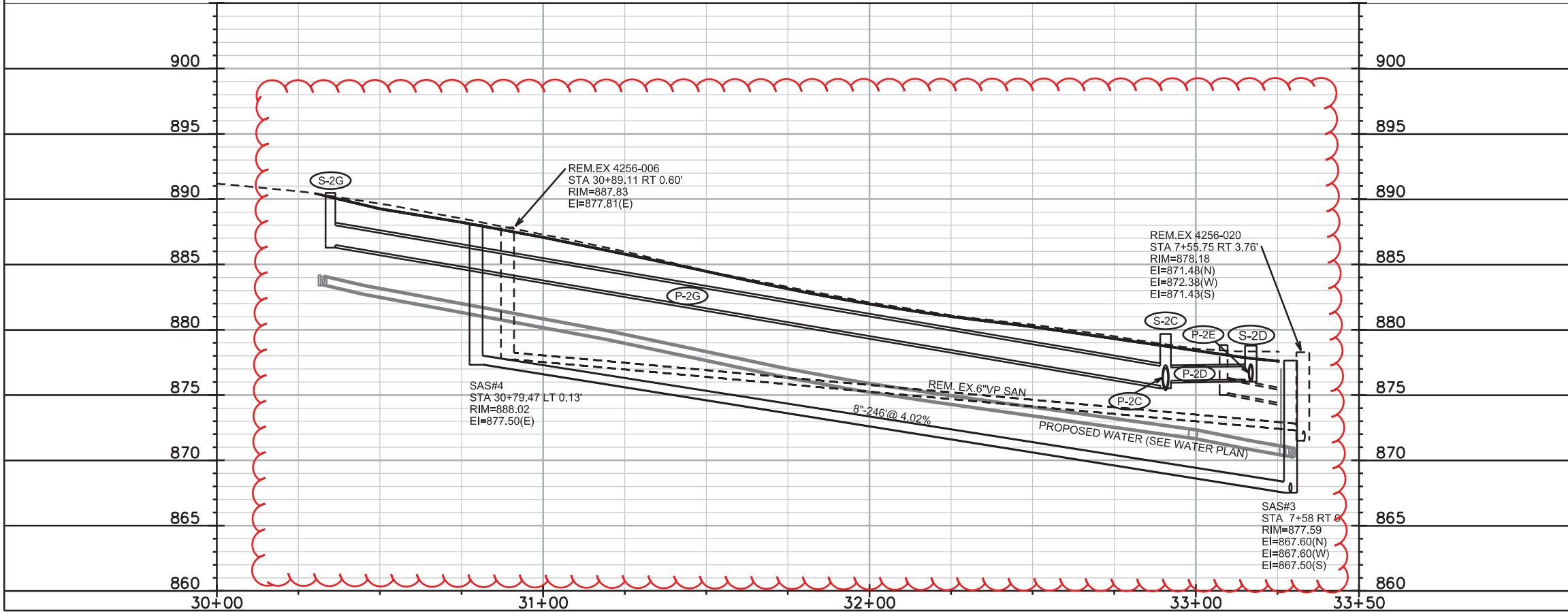

PLOT SCALE: _____

PLOT NAME: _____

REV. DATE: _____

ORIGINATOR: CITY OF MADISON, STREETS DIVISION

SEWER PLAN AND PROFILE

KEYES AVENUE CITY OF MADISON

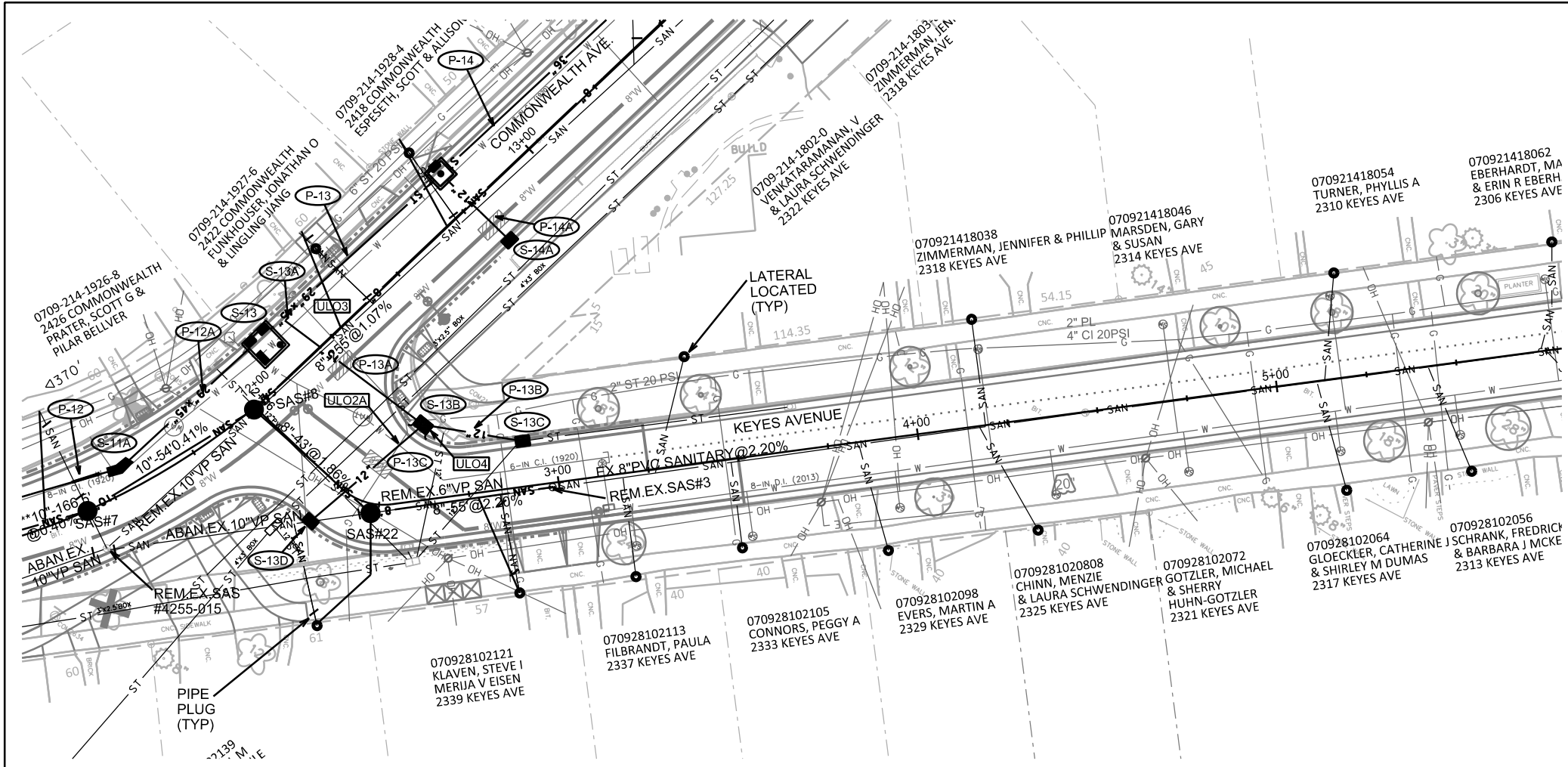
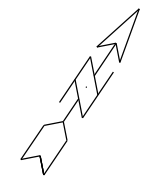

STORM STRUCTURES AND PIPE
REMOVALS SHOWN ON SHEET U-2

CONTRACTOR SHALL REM & REP
SIDEWALK AS NEEDED FOR LATERALS
(MAX. OF 4 SW SQUARES PER LATERAL)

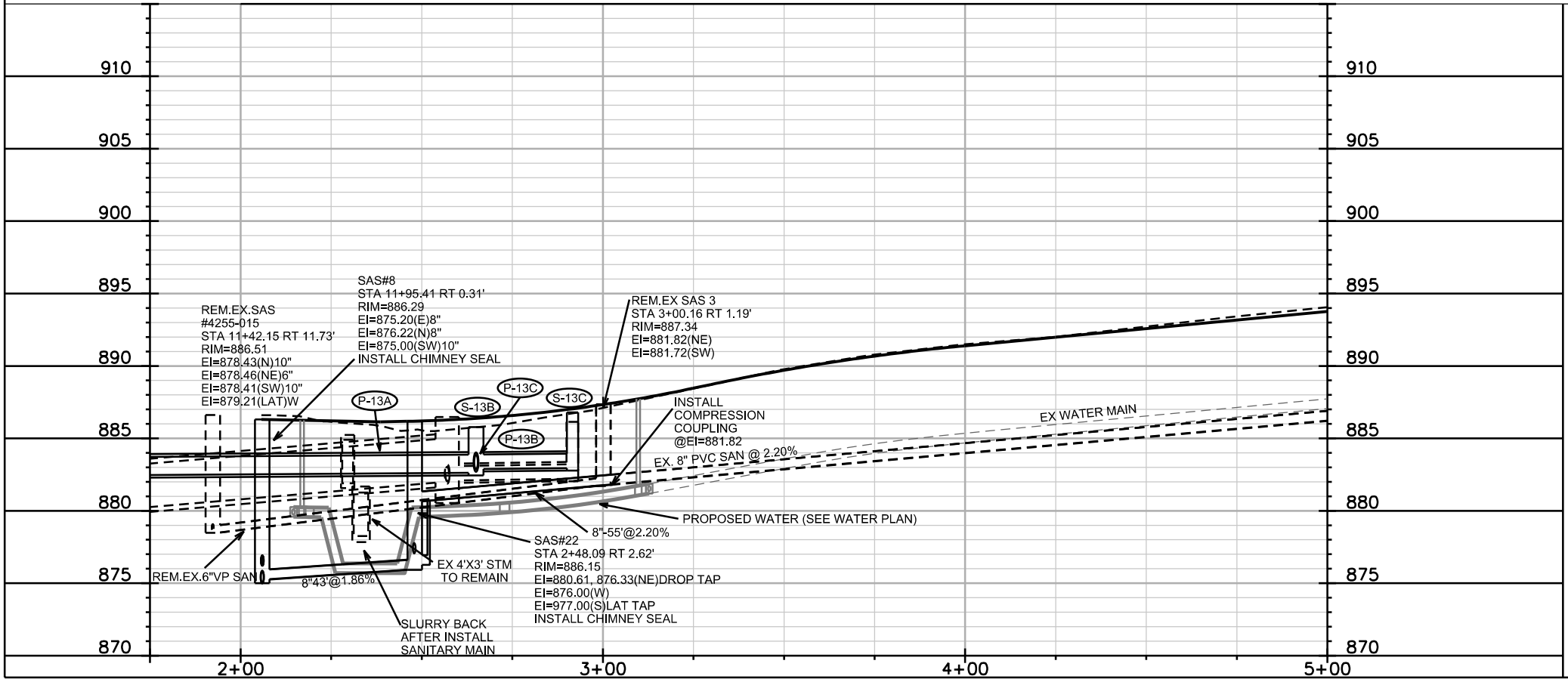

PLOT SCALE: _____

PLOT NAME: _____

REV. DATE: _____

ORIGINATOR: CITY OF MADISON, STREETS DIVISION

SANITARY SCHEDULE

PROPOSED SANITARY STRUCTURES

SAS NO.	STATION	LOCATION (OFFSET)	TOP OF CASTING	E.I.	DEPTH	NOTES
COMMONWEALTH AVE.						
SAS#1	5+25.16	LT-0.21	871.98	863.27	8.71	
SAS#2	6+75.33	LT-0.20	874.42	865.00	9.42	
SAS#3	7+58.00	CL	877.59	867.50	10.09	
SAS#5	9+03.70	LT-0.60	884.55	873.00	11.55	
SAS#6	9+75.07	LT-3.36	887.67	873.91	13.76	
SAS#7	11+41.49	RT-0.13	886.56	874.68	11.88	
SAS#8	11+95.41	RT-0.31	886.29	875.00	11.29	INSTALL CHIMNEY SEAL
SAS#9	14+50.26	LT-0.34	889.21	877.50	11.71	
SAS#10	16+03.66	RT-2.42	890.78	879.00	11.78	OUTSIDE DROPS(3 TOTAL); WEST(2.97'); EAST(6.24'); NORTH(2.55')
SAS#11	16+79.83	RT-1.78	891.44	882.26	9.18	
SAS#12	17+39.42	RT-2.68	892.45	883.24	9.21	
SAS#18	21+40.65	RT-1.71	903.41	896.57	6.84	
SAS#19	22+33.14	LT-1.41	905.35	897.52	7.83	
SAS#20	24+64.59	LT-3.74	909.79	901.00	8.79	
SAS#21	25+65.41	LT-2.11	909.70	900.50	9.20	
SAS#23	15+99.60	LT-21.21	891.41	883.52	7.89	

GREGORY ST

SAS#4	30+79.47	LT-0.13	888.02	877.50	10.52	
-------	----------	---------	--------	--------	-------	--

KEYES AVE.

SAS#22	2+48.09	RT-2.62	886.15	876.00	10.15	OUTSIDE DROP E (880.61, 876.33)INSTALL CHIMNEY SEAL
--------	---------	---------	--------	--------	-------	---

FOX AVE.

SAS#14	43+90.69	RT-0.58	898.72	889.00	9.72	
SAS#15	46+54.44	RT-0.72	905.63	896.20	9.43	
SAS#16	49+21.66	LT-.61	914.42	903.50	10.92	

ADJUST SANITARY STRUCTURES

STRUCTURE	STATION	LOCATION (OFFSET)	EX. TOP OF CASTING	EX. ADJ (ft)	PROP.RIM	NOTES
EX.SAS 4255-019	16+04.26	RT-20.46	890.58	0.25	891.09	4' DIA.
EX.SAS 4256-022	3+22.12	RT-2.38	870.99	0.50	870.72	4X4 SAS
EX.SAS 4254-019	28+77.21	LT-0.85	905.07	0.25	904.91	4' DIA.

REMOVE SEWER ACCESS STRUCTURES

STRUCTURE	STATION	LOCATION	RIM	EI	DEPTH	NOTES
COMMONWEALTH AVE.						
EX 4256-021	5+66.58	LT-1.29	872.61	863.71	8.90	-
EX 4256-020	7+55.75	RT-3.76	878.18	871.43	6.75	-
EX 4256-005	8+98.90	RT-0.93	884.85	877.43	7.42	-
EX 4255-015	11+42.15	RT-11.73	886.51	878.41	8.10	-
EX 4255-014	13+70.61	RT-3.47	888.52	882.00	6.52	-
EX 4255-013	16+03.66	RT-2.42	891.57	885.52	6.05	-
EX 4255-016	16+79.78	LT-0.27	892.61	885.72	6.89	-
EX 4254-024	21+40.53	RT-1.34	903.75	896.57	7.18	-
EX 4254-021	22+33.14	LT-1.41	905.75	897.67	8.08	-
EX 4254-020	24+49.41	LT-0.02	909.91	902.41	7.50	-
EX 4254-018	25+65.41	LT-2.11	910.36	902.56	7.80	-
GREGORY ST						
EX 4256-006	30+89.11	RT-0.60	887.83	877.81	10.02	-
KEYES AVE.						
EX SAS 3	3+00.16	RT-1.19	887.34	881.72	5.62	-
FOX AVE.						
EX 4255-025	41+36.97	RT-0.64	893.18	886.46	6.72	-
EX 4254-025	43+90.69	RT-0.58	898.52	892.41	6.11	-
EX 4254-026	46+54.44	RT-0.72	905.47	899.41	6.06	-
EX 4354-001	49+08.75	LT-0.32	914.05	904.66	9.39	-

PROPOSED SANITARY PIPES

FROM SAS (DWNSTRM)	TO SAS (UPSTREAM)	EI # (DWNSTRM)	EI # (UPSTRM)	LENGTH (FT)	SLOPE (%)	SIZE (DIA)	PVC TYPE	NOTES
COMMONWEALTH AVE.								
EX.SAS#4256-022	SAS#1	862.46	863.27	203	0.40%	10"	SDR-35	RECONSTRUCT BENCH AND FLOWLINES
SAS#1	SAS#2	863.37	865.00	150	1.09%	10"	SDR-35	
SAS#2	SAS#3	865.10	867.50	83	2.89%	10"	SDR-35	
SAS#3	SAS#5	867.60	873.00	146	3.70%	10"	SDR-35	
SAS#5	SAS#6	873.10	873.91	72	1.12%	10"	SDR-26	
SAS#6	SAS#7	874.01	874.68	166.5	0.40%	10"	SDR-26	
SAS#7	SAS#8	874.78	875.00	54	0.41%	10"	SDR-26	
SAS#8	SAS#9	876.22	877.50	255	0.50%	8"	SDR-35	
SAS#9	SAS#10	877.60	879.00	153	0.92%	8"	SDR-35	
SAS#10	SAS#11	881.88	882.26	76	0.50%	8"	AWWA C900	
SAS#10	SAS#23	882.30	883.52	24	5.08%	8"	SDR-35	
SAS#11	SAS#12	882.36	883.24	60	1.47%	8"	AWWA C900	
STA 21+05.07 LT 14.5	SAS#18	895.97	896.57	40	1.50%	6"	SDR-35	COMPRESSION COUPLING
SAS#18	SAS#19	896.69	897.52	93	0.89%	8"	AWWA C900	
SAS#19	SAS#20	897.62	901.00	232	1.46%	8"	SDR-35	
EX.SAS 4254-019	SAS#21	896.32	900.50	312	1.34%	8"	SDR-35	RECONSTRUCT BENCH AND FLOWLINES

GREGORY ST

SAS#3	SAS#4	867.60	877.50	246	4.02%	8"	SDR-35	
-------	-------	--------	--------	-----	-------	----	--------	--

KEYES AVE.

SAS#8	SAS#22	875.20	876.00	43	1.86%	8"	SDR-35	
SAS#22	STA 3+00.16, RT 1.19'	880.61	881.82	55	2.20%	8"	SDR-35	COMPRESSION COUPLING

FOX AVE.

SAS#11	SAS#14	882.36	889.00	381	1.74%	8"	SDR-35	
SAS#14	SAS#15	889.10	896.20	264	2.69%	8"	SDR-35	
SAS#15	SAS#16	896.30	903.50	267	2.70%	8"	SDR-35	
SAS#10	SAS#23	882.30	883.52	24	5.08%	8"	SDR-35	

SANITARY SEWER PIPE REMOVAL

FROM SAS (DWNSTRM)	TO SAS (UPSTREAM)	LENGTH (FT)	PAID (Y/N)	PAID LENGTH*	SIZE (DIA in)	PIPE TYPE	NOTES
COMMONWEALTH AVE.							
EX 4256-022	EX 4256-021	244.5	N	0	10"	VP	-
EX 4256-021	EX 4256-020	189	Y	102	10"	VP	-
EX 4256-020	EX 4256-005	143	N	0	10"	VP	-
EX 4255-015	SAS#8	55	Y	55	10"	VP	-
SAS#8	EX 4255-014	220	Y	16	10"	VP	-
EX 4255-014	EX 4255-013	233	Y	130	10"	VP	-
EX 4255-013	SAS#23	24	N	0	8"	VP	-
EX 4255-013	EX 4255-016	76	N	0	8"	VP	-
STA 21+04.07, LT-14.5	EX 4254-024	40	N	0	6"	VP	-
EX 4254-024	EX 4254-021	93	N	0	6"	VP	-
EX 4254-021	EX 4254-020	216	N	0	6"	VP	-
EX 4254-019	EX 4254-018	312	N	0	12"	VP	-

GREGORY ST

EX 4256-020	EX 4256-006	240	N	0	6"	VP	-
-------------	-------------	-----	---	---	----	----	---

KEYES AVE.

STA 2+48.09, RT-2.62	EX SAS 3	53	N	0	6"	VP	-
----------------------	----------	----	---	---	----	----	---

FOX AVE.

EX 4255-016	EX 4255-025	128	N	0	6"	VP	-
EX 4255-025	EX 4254-025	254	N	0	6"	VP	-
EX 4254-025	EX 4254-026	264	N	0	6"	VP	-
EX 4254-026	EX 4354-001	255.5	N	0	6"	VP	-

*PAY LENGTH IS LENGTH OF PIPE 3' OR GREATER AWAY FROM EXISTING PIPE (PIPE OUTSIDE LIMITS OF TRENCH)

SANITARY SEWER PIPE ABANDONMENT

FROM SAS (DWNSTRM)	TO SAS (UPSTREAM)	LENGTH Feet	PAID (Y/N)	SIZE (DIA in)	PIPE TYPE	NOTES
EX 4256-005	EX 4255-015	241	Y	10	VP	PIPE PLUGS BOTH PIPE ENDS
EX 4255-015	STA 2+48.09, RT-2.62	73	Y	6	VP	PIPE PLUGS BOTH PIPE ENDS

STORM SEWER SCHEDULE

*REVISED 05-16-2014 ELD

COMMONWEALTH, FOX, GREGORY & KEYES	SHEET NO.
PROJECT NO. 53W0615	U-12
STORM SEWER SCHEDULE	
COMMONWEALTH/FOX/GREGORY/KEYES	CITY OF MADISON

PROPOSED STORM STRUCTURES

STRUC. NO.	STATION	LOCATION (OFFSET)	TYPE	TOP OF CASTING	E.I.	DEPTH	NOTES
COMMONWEALTH AVE							
S-1	6+84.85	RT-21.36	CONCRETE COLLAR	DNA	870.25	4.65	(1)
S-2	7+34.78	RT-21.37	5X5 SAS	876.82	871.47	5.35	W/R1550-0054
* S-2A	7+34.85	RT-14.50	H INLET	876.76	873.70	3.06	W/R-3067-7004-V, FP
* S-2D	7+71.66	LT-12.73	H INLET	878.77	876.21	2.56	FP, W/R-3067-7004-VB, LP, UD
S-2E	8+17.50	LT-14.50	H INLET	880.65	876.65	4.00	W/R-3067-7004-V
S-2F	8+17.61	RT-14.50	H INLET	880.16	876.92	3.24	W/R-3067-7004-V
S-3	7+57.50	RT-22.73	CONCRETE COLLAR	DNA	872.00	5.40	(1)
S-10	9+56.73	RT-24.26	5X5 SAS	887.00	879.00	8.00	FP, W/R1550-0054
S-11	10+05.90	LT-7.18	45° BEND	DNA	879.05	8.77	(5), INCIDENTAL TO PIPE
S-11A	11+54.92	LT-6.58	22.5° BEND	DNA	879.19	7.31	(5), INCIDENTAL TO PIPE
S-13	12+10.07	LT-11.06	TREATMENT DEVICE	886.47	879.24	7.23	(2), LP, UD
S-13A	12+18.67	LT-10.75	STM TAP	DNA	882.50	3.70	(5)
S-14	12+77.59	LT-9.91	5X5 SAS	887.10	881.80	5.30	(3), (7), W/R-3067-7004-V
S-14A	12+78.76	RT-14.50	H INLET	886.73	883.50	3.23	W/R-3067-7004-V
S-14B	14+22.93	LT-7.75	STM TAP	DNA	883.11	5.59	(5)
S-14C	14+24.39	RT-36.00	H INLET	888.60	885.00	3.60	W/R-1878-B7G
* S-15AA			4X4 SAS	890.10	884.44	5.66	W/R-3067-7004-V
S-15	16+10.19	LT-13.38	4X4 SAS	891.10	884.50	6.60	W/R1550-0054
S-15A	16+09.50	LT-34.73	3X3 SAS	891.65	886.19	5.46	FP, W/R1550-0054
S-15B	16+02.71	LT-35.07	H INLET	891.58	887.63	3.95	W/R-3067-7004-VB, LP, UD
S-15C	16+11.08	RT-23.95	CONCRETE COLLAR	DNA	886.25	-	
S-16	16+81.25	LT-15.01	3X3 SAS	892.44	887.34	5.10	(6), W/R1550-0054, LP, UD
* S-16A	17+16.95	RT-14.50	H INLET	891.95	890.23	1.72	FP, W/R-3067-7004-V
* S-17	18+05.16	LT-11.01	3X3 SAS	895.14	887.94	7.20	W/R-3067-7004-V
* S-17A	18+11.63	RT-14.50	H INLET	894.26	888.56	5.70	FP, W/R-3067-7004-V
S-18	20+53.01	LT-14.50	H INLET	902.40	898.23	4.17	W/R-3067-7004-V
S-18A	20+60.81	RT-14.50	H INLET	902.43	898.90	3.53	W/R-3067-7004-V
S-19	21+78.23	LT-9.50	H INLET	904.35	900.24	4.11	W/R-3067-7004-V
S-20	22+38.83	LT-17.27	H INLET	905.70	902.06	3.64	W/R-3067-7004-VB, LP, UD
S-21	22+71.89	LT-14.50	H INLET	906.25	902.70	3.55	W/R-3067-7004-V
S-22	22+99.65	RT-14.50	H INLET	906.59	903.07	3.52	W/R-3067-7004-V
GREGORY STREET							
* S-2B	32+86.84	RT-13.50	H INLET	878.60	875.08	3.52	FP, W/R-3067-7004-V
* S-2C	32+90.73	LT-13.50	H INLET	879.68	875.59	4.09	FP, W/R-3067-7004-V
S-2G	30+34.85	LT-13.50	H INLET	890.48	886.61	3.87	FP, W/R-3067-7004-V
KEYES AVENUE							
S-13B	2+65.00	LT-20.57	TERRACE INLET TYPE 3	885.77	882.61	3.16	(4), LP, UD
S-13C	2+90.10	LT-13.00	H INLET	886.78	882.93	3.19	W/R-3067-7004-V
S-13D	2+38.43	RT-12.50	H INLET	886.34	882.95	3.39	W/R-3067-7004-VB, LP, UD
FOX AVENUE							
S-17B	41+55.42	LT-12.50	H INLET	893.61	889.80	3.81	W/R-3067-7004-V
S-17C	43+80.60	LT-12.50	H INLET	898.37	894.24	4.13	W/R-3067-7004-V
S-17D	43+79.88	RT-12.50	H INLET	898.70	894.95	3.75	W/R-3067-7004-V
* S-17E	41+06.12	LT-28.41	H INLET	893.00	889.48	3.52	W/R-3067-7004-VB, LP, UD
S-50	41+05.38	RT-12.50	H INLET	892.35	890.40	1.95	FP, W/R-3067-7004-V

PROPOSED STORM PIPES

PIPE NO.	FROM (DNSTM)	TO (UPSTM)	PLAN LGTH (FT)	PIPE LGTH (FT)	DISCH. E.I.	INLET E.I.	SLOPE (%)	PIPE SIZE	TYPE	NOTES
P-1	S-1	S-2	50	47.5	870.25	871.47	2.57	29" X 45"	HERCP	-
P-2	S-2	S-3	23	20.5	871.47	872.00	2.62	29" X 45"	HERCP	-
* P-2A	S-2	S-2A	7	3.5	873.01	873.70	20.00	18"	RCP	-
* P-2B	S-2A	S-2B	49	46	873.01	875.08	3.00	18"	RCP	-
* P-2C	S-2B	S-2C	27.5	25.5	875.08	875.59	2.00	18"	RCP	-
* P-2D	S-2C	S-2D	26.5	23	876.09	876.21	0.50	12"	RCP	-
* P-2E	S-2D	S-2E	46	43	876.21	876.65	1.03	12"	RCP	-
P-2F	S-2E	S-2F	28.5	26.5	876.65	876.92	1.00	12"	RCP	-
* P-2G	S-2E	S-2G	256	253	875.59	886.61	4.26	18"	RCP	-
P-11	S-10	S-11	57.5	51	879.00	879.05	0.10	29" X 45"	HERCP	-
P-12	S-11	S-11A	148	143.5	879.05	879.19	0.10	29" X 45"	HERCP	-
P-12A	S-11A	S-13	53	47	879.20	879.24	0.10	29" X 45"	HERCP	-
P-13	S-13	S-14	67.5	60.5	881.74	881.80	0.10	29" X 45"	HERCP	-
P-13A	S-13A	S-13B	46.5	44.5	882.50	882.61	0.25	15"	RCP	SEE ULO102B
P-13B	S-13B	S-13C	28	24	882.87	882.93	0.25	12"	RCP	-
P-13C	S-13B	S-13D	41	39	882.85	882.95	0.25	12"	RCP	-
* P-14	S-14	S-15AA	267	265.5	881.80	883.44	0.62	36"	RCP	-
P-14A	S-14A	S-14	24.5	20.5	883.30	883.50	1.00	12"	RCP	-
P-14B	S-14B	S-14C	45	44	884.34	885.00	1.50	12"	RCP	-
* P-15AA	S-15AA	S-15	63.5	59	884.44	884.50	0.10	24"X38"	HERCP	(8)
* P-15	S-15	S-16	71.5	67.5	884.75	887.34	3.85	21"	RCP	-
P-15A	S-15	S-15A	21.5	17.5	885.67	886.19	3.00	24"	RCP	-
P-15B	S-15A	S-15B	7	4.5	887.19	887.63	10.00	12"	RCP	-
P-15C	S-15	S-15C	37.5	35	886.00	886.25	0.72	24"	RCP	-
* P-16	S-16	S-17	124	121	887.34	887.94	0.50	21"	RCP	-
P-16A	S-16	S-16A	46.5	43	888.09	890.23	5.00	15"	RCP	-
P-16B	S-16A	FREE END	21	20	890.57	890.84	1.37	8"	PVC	END STA 40+81.58, RT-29.91
* P-17	S-17	S-18	248	245	888.44	898.23	4.00	15"	RCP	-
* P-17A	S-17	S-17A	26.5	24	888.44	888.56	0.50	15"	RCP	-
* P-17B	S-17A	S-17B	53	51	888.56	889.80	2.44	15"	RCP	-
P-17C	S-17B	S-17C	225.5	222.5	889.80	894.24	2.00	15"	RCP	-
P-17D	S-17C	S-17D	25.5	23.5	894.49	894.95	2.00	12"	RCP	-
* P-17E	S-17A	S-17E	31	28	889.06	889.48	1.50	12"	RCP	-
P-18	S-18	S-19	125	122	898.23	900.24	1.65	15"	RCP	-
P-18A	S-18A	S-18	30	28	898.48	898.90	1.50	12"	RCP	-
P-19	S-19	S-20	61.5	58.5	900.24	902.06	3.10	15"	RCP	-
P-20	S-20	S-21	34	31	902.31	902.70	1.25	12"	RCP	-
P-21	S-21	S-22	40.5	37.5	902.70	903.07	1.00	12"	RCP	-
P-50	FREE END	S-50	24	22.5	890.34	890.40	0.25	8"	PVC	END STA 40+88.52, RT-21.95

NOTE: PLAN LENGTH IS FROM CENTER OF STRUCTURE TO CENTER OF STRUCTURE. PIPE LENGTH IS ACTUAL LENGTH OF PIPE FROM STRUCTURE WALL TO STRUCTURE WALL. SLOPE CALCULATED USING PIPE LENGTH.

STANDARD NOTES:

- ABBREVIATIONS: AE = APRON ENDWALL; RCP = REINFORCED CONCRETE PIPE; HERCP = HORIZONTAL ELLIPTICAL REINFORCED CONCRETE PIPE; DNA = DOES NOT APPLY; SAS = SEWER ACCESS STRUCTURE; LP = LOW POINT INLET STRUCTURE; FP = FIELD POURED STRUCTURE; TR = TOP OF CONCRETE ROOF; NCM = NO CROWN MATCH FOR PIPES; UD = UNDERDRAIN

- APPROXIMATE DISCHARGE E.I. GIVEN, ADJUST E.I. AND PIPE SLOPE IN THE FIELD.

- TOP OF CASTING GRADE GIVEN IS THE TOP OF CURB FOR INLET STRUCTURES AND THE FLOWLINE OF THE CLOSED CASTING FOR SAS's.

- TOP OF CONCRETE ROOF (TR) IS 1.25' BELOW TOP OF CASTING UNLESS OTHERWISE NOTED.

- ALL REINFORCED CONCRETE PIPES TO BE CLASS III UNLESS OTHERWISE NOTED.

- SURVEYOR TO CONFIRM THAT ALL INLET STATION / OFFSETS LINE UP WITH PROPOSED CURB AND GUTTER.

- ALL STRUCTURES CALLED OUT AS FIELD POURED SHALL BE FIELD POURED. ALL OTHER STRUCTURES (NOT INDICATED AS FIELD POURED) SHALL BE SUBMITTED TO CITY ENGINEERING FOR APPROVAL IF PRECAST STRUCTURES ARE PREFERRED. CONTACT ERIC DUNDEE OF CITY ENGINEERING AT (608) 266-4913 FOR PRECAST APPROVALS, FAX SHOP DRAWINGS TO (608)264-9275, OR EMAIL SHOP DRAWINGS TO EDUNDEE@CITYOFMADISON.COM.

SPECIFIC NOTES

(1) PAID PER BID ITEM 90033 CONCRETE COLLAR (BOX CULVERT)

(2) SCREEN TREATMENT DEVICE PER DETAIL SHEET U-14

(3) TOP OF CASTING = TOP OF CURB ELEVATION

(4) TOP OF GRATE = 885.57, GRATE IS NEENAH COMPONENT NUMBER 38080007

(5) PLACE MARKER BALL ABOVE BENDS AND TAPS

(6) PRIVATE CONNECTION TYPE II

(7) TWO CASTINGS, ONE R-3067-7004-V AND ONE R1550-0054

(8) REQUIRES EXISTING STORM BOX ROOF REPLACEMENT

STORM SEWER SCHEDULE

REVISED 05-16-2014 ELD

COMMONWEALTH, FOX, GREGORY & KEYES	SHEET NO.
PROJECT NO. 53W0615	U-13
STORM SEWER SCHEDULE	
COMMONWEALTH/FOX/GREGORY/KEYES	CITY OF MADISON

REMOVE STORM STRUCTURES

STRUC. NO.	ID NO.	STATION	LOCATION (OFFSET)	TYPE	NOTES
COMMONWEALTH AVE					
R-1	AS 4256-002	7+29.35	RT-21.09	CATCHBASIN	-
R-2	IN 4256-003	7+33.66	LT-19.32	INLET	-
R-3	IN 4256-004	7+71.89	LT-21.70	INLET	-
R-4	AS 4256-022	9+58.59	RT-24.08	CATCHBASIN	-
R-5	IN 4255-035	11+94.36	LT-16.23	INLET	-
R-6	IN 4255-076	15+50.71	LT-19.48	INLET	-
R-7	IN 4255-032	11+81.78	RT-42.48	INLET	-
R-8	AS 4255-031	12+00.98	RT-60.62	CATCHBASIN	-
R-9	IN 4255-034	12+02.15	RT-56.80	INLET	-
R-10	IN 4255-024	12+30.31	RT-39.53	INLET	-
R-11	IN 4255-033	12+43.78	RT-56.28	INLET	-
R-12	IN 4255-021	16+10.82	LT-21.55	INLET	-
R-13	IN 4255-037	16+66.29	LT-15.17	INLET	-
R-14	AS 4255-020	16+11.40	LT-15.17	5'X5' SAS	-
R-15	AS 4255-036	17+18.03	RT-19.26	CATCHBASIN	-
R-16	IN 4255-041	17+04.57	RT-35.95	INLET	-
R-17	CB 4255-071	17+26.55	RT-53.5	CATCHBASIN	-
R-18	IN 4255-040	17+28.66	RT-49.46	INLET	-
R-19	IN 4255-077	17+89.01	RT-35.22	INLET	-
R-20	IN 4255-039	17+92.52	RT-52.93	INLET	-
R-21	AS 4254-041	19+95.79	RT-19.00	CATCHBASIN	-
R-22	IN 4254-049	20+20.98	LT-15.15	INLET	-
R-23	IN 4254-046	20+66.73	RT-14.96	INLET	-
R-24	IN 4254-033	21+89.45	LT-21.52	INLET	-
R-25	AS 4254-031	21+91.61	RT-18.40	CATCHBASIN	-
R-26	IN 4254-104	22+40.05	LT-20.48	DOUBLE INLET	-

STORM SEWER ULOS

ULO NO.	STATION	LOCATION (OFFSET)	TYPE	NOTES
ULO1A	7+34.3	LT 26.2	GAS(874.34 TOP 8IN)	REVISED STORM S-2 TO S-2E
ULO2A	7+65.5	LT 25.8	GAS(875.57 TOP 8IN)	REVISED STORM S-2 TO S-2E
ULO2AA	12+17.7	RT 34.9	GAS(880.63 TOP 11IN)	NO CONFLICT
ULO3A	12+25.3	LT 11.6	GAS(882.43 TOP 2IN)	GAS RELOCATION NEEDED
ULO4A	12+27.6	RT 34.1	GAS(881.41 TOP 2IN)	NO CONFLICT
ULO5A	14+23.6	RT 14.8	TELE(887.82 COAX)	NO CONFLICT
ULO6A	15+96.9	LT 11.5	GAS(887.26 TOP 4IN)	GAS RELOCATION NEEDED
ULO6B	15+93.9	LT 10.8	GAS(888.33 TOP 12IN)	REVISED STORM S-14 TO S-16
ULO7A	16+12.8	LT 26.1	GAS(884.78 TOP 8IN)	NO CONFLICT
ULO7B	16+10.0	LT 24.6	TE(889.18 TOP CONC DUCT)	NO CONFLICT
ULO8A	16+08.0	LT 0.9	GAS(888.59 TOP 12IN AT 45 DOWN BEND)	GAS CONCRETE CAP TO BE REMOVED
ULO8AA	16+67.2	LT 27.0	GAS(889.12 TOP 8IN)	PRIVATE STORM CONNECTION-NO CONFLICT
ULO9A	17+09.5	RT 8.0	GAS(889.15 TOP 12IN)	NO CONFLICT
ULO10A	17+18.0	RT 12.5	ELEC(889.94 TOP DOUBLE 6IN)	RELOCATE ELECTRIC
ULO11A	18+10.3	RT 8.1	GAS(891.64 TOP 12IN)	REVISED STORM P-16 TO S-17B
ULO12A	18+11.3	RT 60.1	WATER(887.63 BW 8IN)	REVISED STORM P-16 TO S-17B
ULO13A	18+12.5	RT 12.7	ELEC(891.84 TOP 6IN)	RELOCATE ELECTRIC
ULO13B	18+12.5	RT 12.0	ELEC(891.89 TOP 6IN)	RELOCATE ELECTRIC
ULO14A	19+26.3	LT 12.4	ELEC(896.52 TOP 6IN)	NO CONFLICT
ULO14B	19+25.5	LT 12.5	ELEC(896.54 TOP 6IN)	NO CONFLICT
ULO15A	20+59.7	RT 8.1	GAS(895.5 TOP 12IN)	NO CONFLICT
ULO16A	22+92.2	RT 7.6	GAS(901.4 TOP 12IN)	NO CONFLICT
ULO16B	22+91.6	RT 9.3	GAS(903.36 TOP 11IN)	GAS RELOCATION NEEDED
ULO101A	7+73.5	LT 12.7	GAS(876.01 TOP 11IN)	GAS RELOCATION NEEDED
ULO102A	12+24.4	RT 28.6	GAS(883.7 TOP 2IN)	GAS RELOCATION NEEDED
ULO102B	12+23.4	RT 29.1	TE(882.34 TOP BOX)	REVISED STORM - NO BELL OVER BOX
ULO103A	17+67.4	LT 11.4	GAS(890.4 TOP 4IN)	NO CONFLICT
ULO104A	19+64.6	LT 12.2	FO(897.92 TOP 3IN)	NO CONFLICT
ULO104B	19+64.5	LT 11.9	ELEC(897.7 TOP 1IN)	NO CONFLICT

REMOVE STORM PIPES

REMOVE NO.	REMOVE FROM	REMOVE TO	LGTH (FT)	PIPE SIZE	PIPE TYPE	PAID (Y/N)	NOTES
COMMONWEALTH AVE							
RP-1	S-1	R-1	40	3'X2.5'	RCP BOX	N	-
RP-2	R-1	S-3	29	3'X2.5'	RCP BOX	N	-
RP-3	R-1	R-2	40	12"	VP	N	-
RP-4	R-1	R-3	57	12"	VP	Y	-
RP-5	R-8	R-5	75	12"	VP	Y	50 L.F. IN SANITARY TRENCH INCIDENTAL
RP-6	STA 11+50, RT-33.50	STA 12+50, RT-22.50	100	3'X2.5'	RCP BOX	Y	-
RP-7	EX AS 4255-023	R-7	11	12"	VP	Y	-
RP-8	STA 11+50, RT-33.50	R-8	63	18"	VP	Y	-
RP-9	R-8	R-9	3	12"	VP	Y	-
RP-10	R-8	R-10	35	12"	VP	Y	-
RP-11	R-8	R-11	42	12"	VP	Y	-
RP-12	STA 15+50, RT-16.50	R-6	35	12"	PVC	Y	-
RP-13	STA 15+70, RT-15.25	R-14	41	3'X2.5'	RCP BOX	Y	-
RP-14	R-14	STA 16+11.08, RT-24.00	11	24"	RCP	N	-
RP-15	R-14	STA 16+09.50, LT-35.00	48	24"	RCP	N	-
RP-16	R-14	R-13	58	18"	RCP	Y	-
RP-17	R-14	R-15	104	18"	VP	Y	-
RP-18	R-15	R-21	273	12"	VP	Y	-
RP-19	R-15	R-19	70	12"	VP	Y	-
RP-20	R-15	R-17	32	12"	VP	Y	-
RP-21	R-15	R-16	18	12"	VP	Y	-
RP-22	R-17	R-18	3	12"	VP	Y	-
RP-23	R-17	R-20	62	12"	VP	Y	-
RP-24	R-21	R-22	40	12"	VP	Y	-
RP-25	R-21	R-23	67	12"	VP	Y	-
RP-26	R-21	R-25	192	12"	VP	Y	-
RP-27	R-25	R-24	37	12"	VP	Y	-
RP-28	R-25	R-26	59	12"	VP	Y	-

STORM SEWER ABANDONMENTS

PIPE NO.	FROM (DNSTM)	TO (UPSTM)	LGTH (FT)	PIPE SIZE	TYPE	PAID (Y/N)	NOTES
ABP-1	R-4	STA 11+50, RT-33.5	195	3'X2.5'	RCP BOX	Y-PLUGS	-
ABP-2	STA 12+50, RT-22.50	STA 15+70, RT-15.25	320	3'X2.5'	RCP BOX	Y	PER BID ITEM 90035

STORM STRUCTURE ADJUSTMENTS

ADJUST NO.	STATION	LOCATION (OFFSET)	EX. TOC ELEV.	ADJUST ELEV.	ADJUST DIFF.	NOTES
ADJ-1	11+81.10	RT-29.40	885.74	886.46	0.72	CATCHBASIN
ADJ-2	13+50.60	RT-27.85	887.68	888.16	0.48	SAS
ADJ-3	15+21.75	RT-25.75	889.72	890.20	0.48	CATCHBASIN

STANDARD NOTES:

- ABBREVIATIONS: AE = APRON ENDWALL; RCP = REINFORCED CONCRETE PIPE; HERCP = HORIZONTAL ELLIPTICAL REINFORCED CONCRETE PIPE; DNA = DOES NOT APPLY; SAS = SEWER ACCESS STRUCTURE; LP = LOW POINT INLET STRUCTURE; FP = FIELD POURED STRUCTURE; TR = TOP OF CONCRETE ROOF; NCM = NO CROWN MATCH FOR PIPES; UD = UNDERDRAIN
- APPROXIMATE DISCHARGE E.I. GIVEN, ADJUST E.I. AND PIPE SLOPE IN THE FIELD.
- TOP OF CASTING GRADE GIVEN IS THE TOP OF CURB FOR INLET STRUCTURES AND THE FLOWLINE OF THE CLOSED CASTING FOR SAS's.
- TOP OF CONCRETE ROOF (TR) IS 1.25' BELOW TOP OF CASTING UNLESS OTHERWISE NOTED.
- ALL REINFORCED CONCRETE PIPES TO BE CLASS III UNLESS OTHERWISE NOTED.
- SURVEYOR TO CONFIRM THAT ALL INLET STATION / OFFSETS LINE UP WITH PROPOSED CURB AND GUTTER.
- ALL STRUCTURES CALLED OUT AS FIELD POURED SHALL BE FIELD POURED. ALL OTHER STRUCTURES (NOT INDICATED AS FIELD POURED) SHALL BE SUBMITTED TO CITY ENGINEERING FOR APPROVAL IF PRECAST STRUCTURES ARE PREFERRED. CONTACT ERIC DUNDEE OF CITY ENGINEERING AT (608) 266-4913 FOR PRECAST APPROVALS, FAX SHOP DRAWINGS TO (608)264-9275, OR EMAIL SHOP DRAWINGS TO edundee@cityofmadison.com.

REV #1
05.23.2014

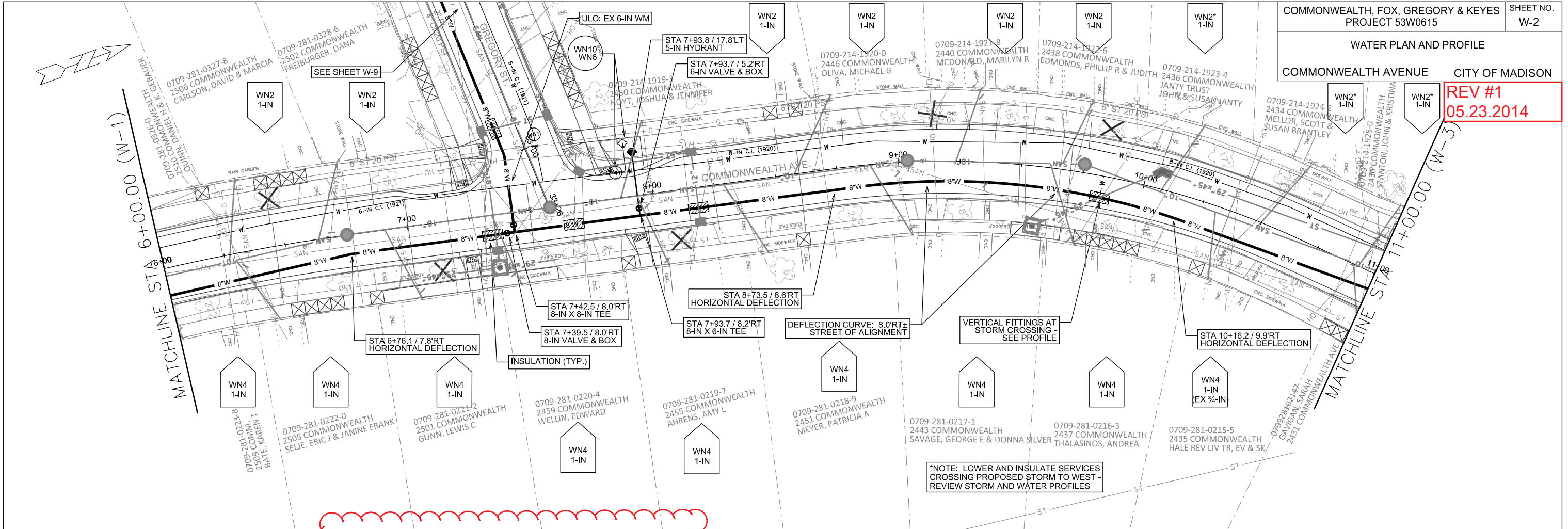

*NOTE: LOWER AND INSULATE SERVICES CROSSING PROPOSED STORM TO WEST - REVIEW STORM AND WATER PROFILES

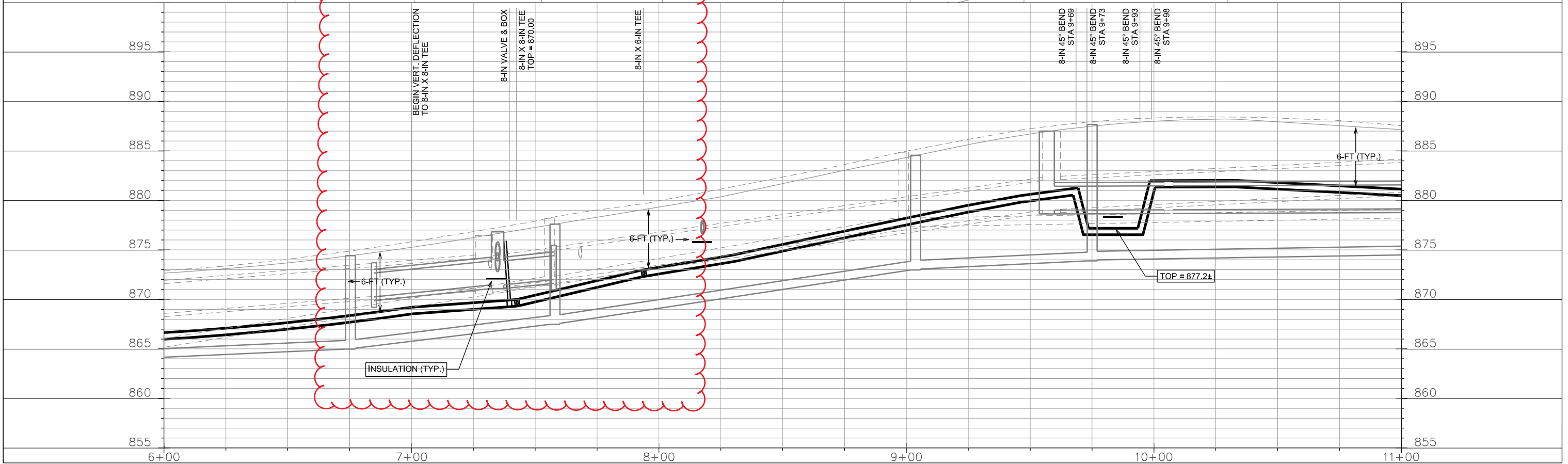

PLOT SCALE:

PLOT NAME:

REV. DATE:

ORIGINATOR: CITY OF MADISON, STREETS DIVISION

REV #1 05.23.2014

*NOTE: LOWER AND INSULATE SERVICES CROSSING PROPOSED STORM TO WEST- REVIEW STORM AND WATER PROFILES

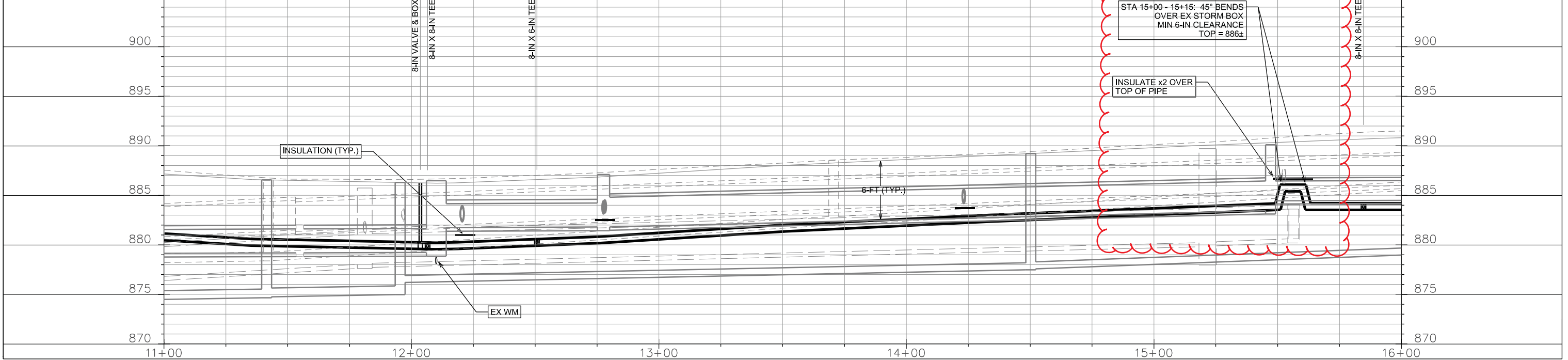
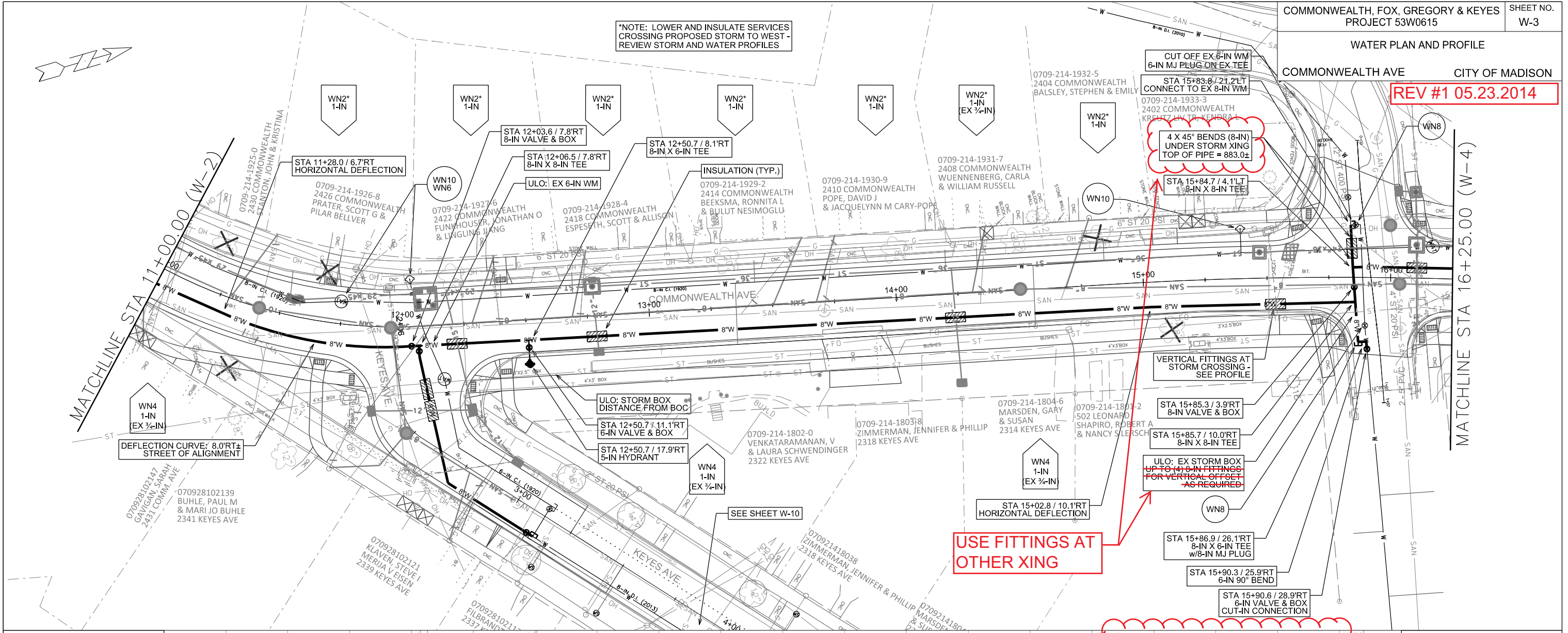

PLOT SCALE:

PLOT NAME:

REV. DATE:

ORIGINATOR: CITY OF MADISON, STREETS DIVISION

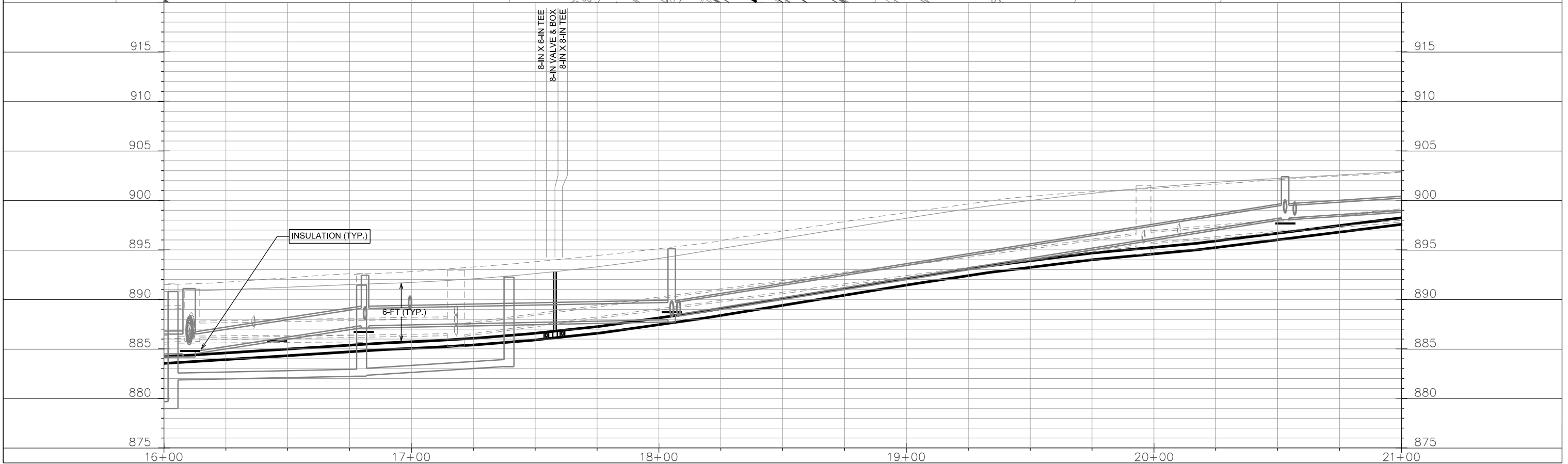
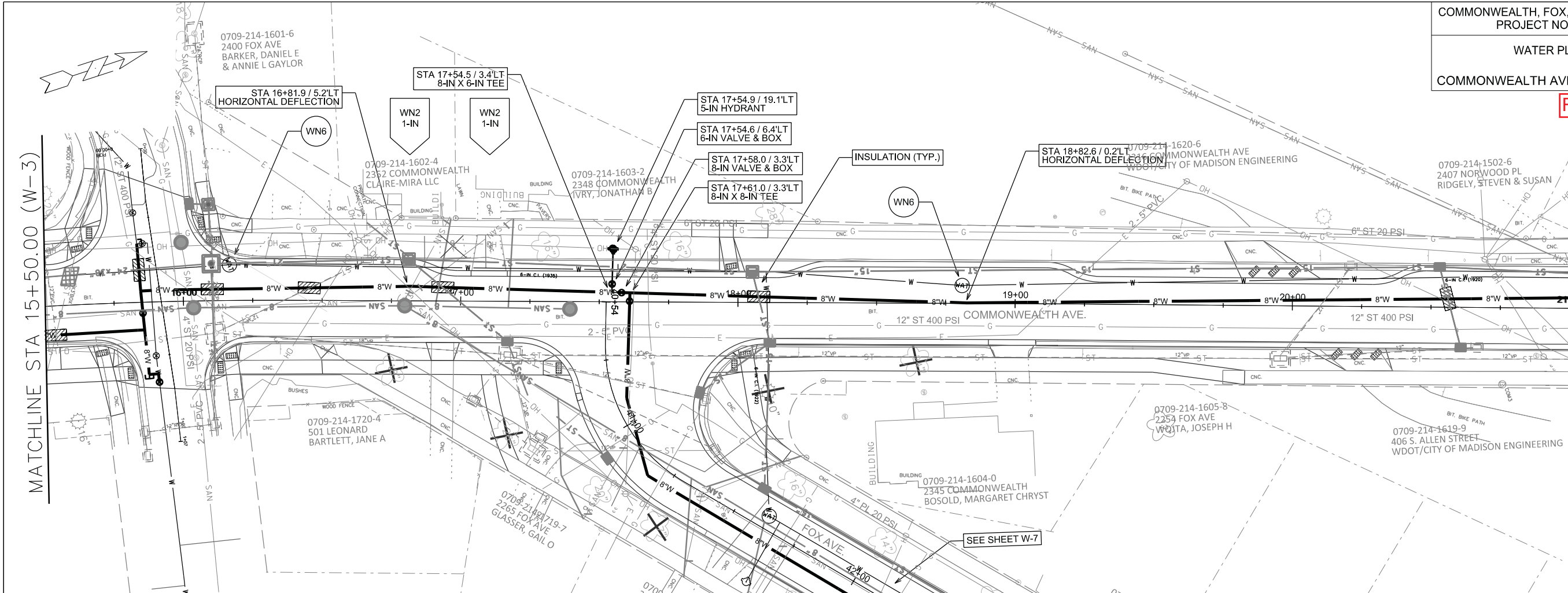

PLOT SCALE:

PLOT NAME:

REV. DATE:

ORIGINATOR: CITY OF MADISON, STREETS DIVISION

WATER PLAN AND PROFILE
COMMONWEALTH AVENUE CITY OF MADISON

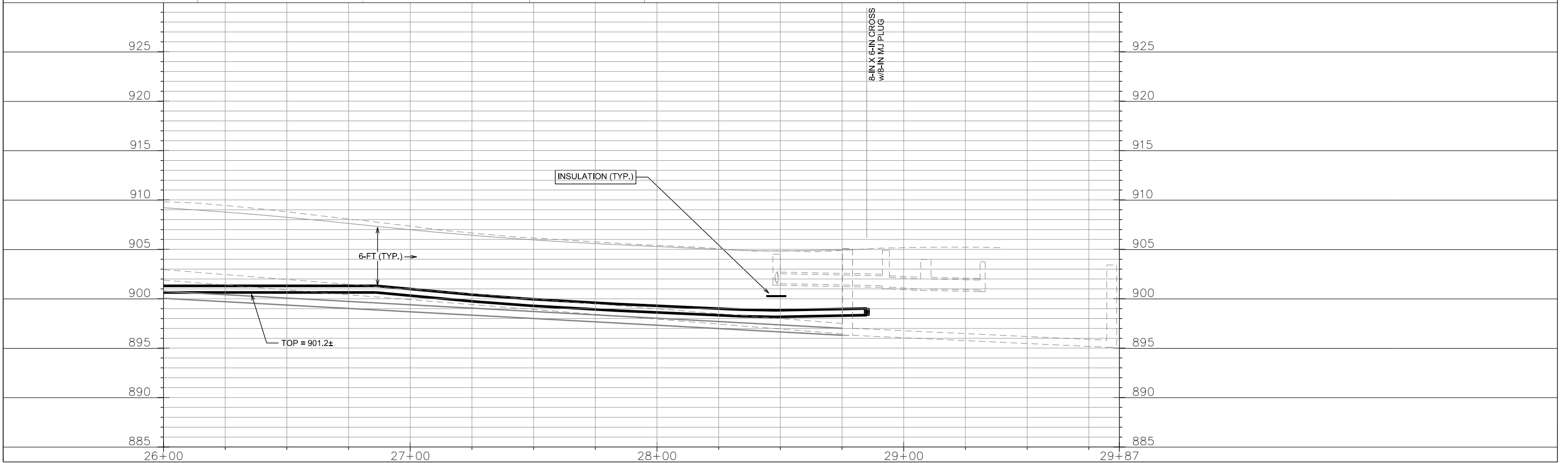
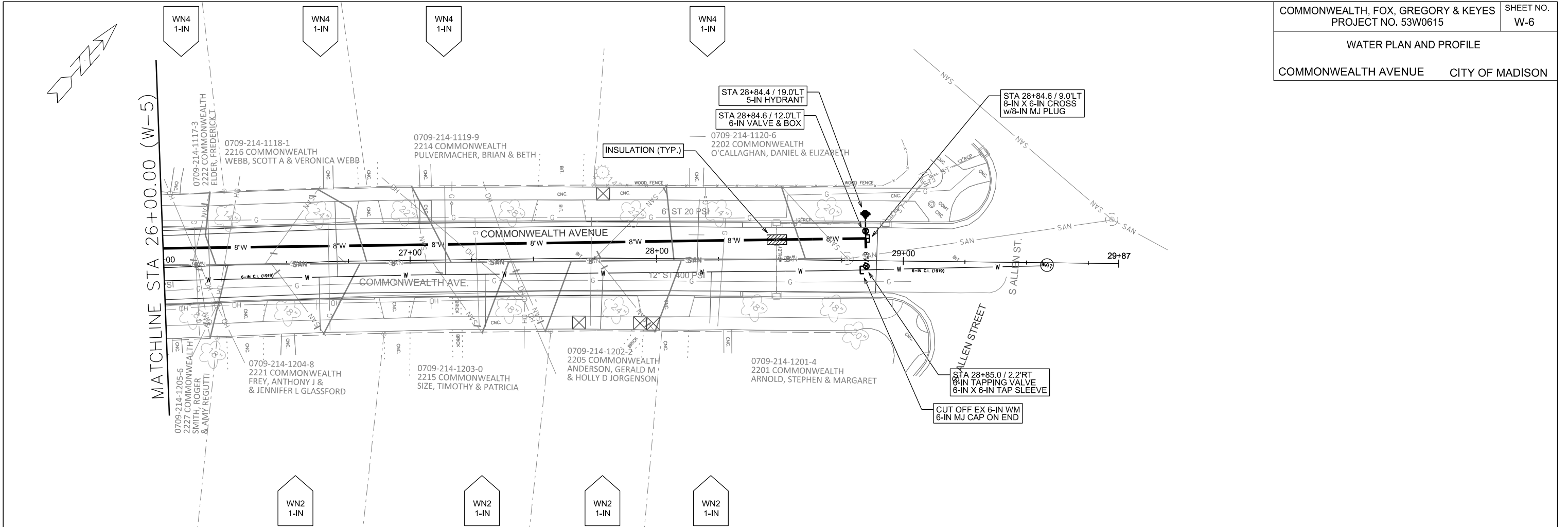

PLOT SCALE:

PLOT NAME:

REV. DATE:

ORIGINATOR: CITY OF MADISON, STREETS DIVISION

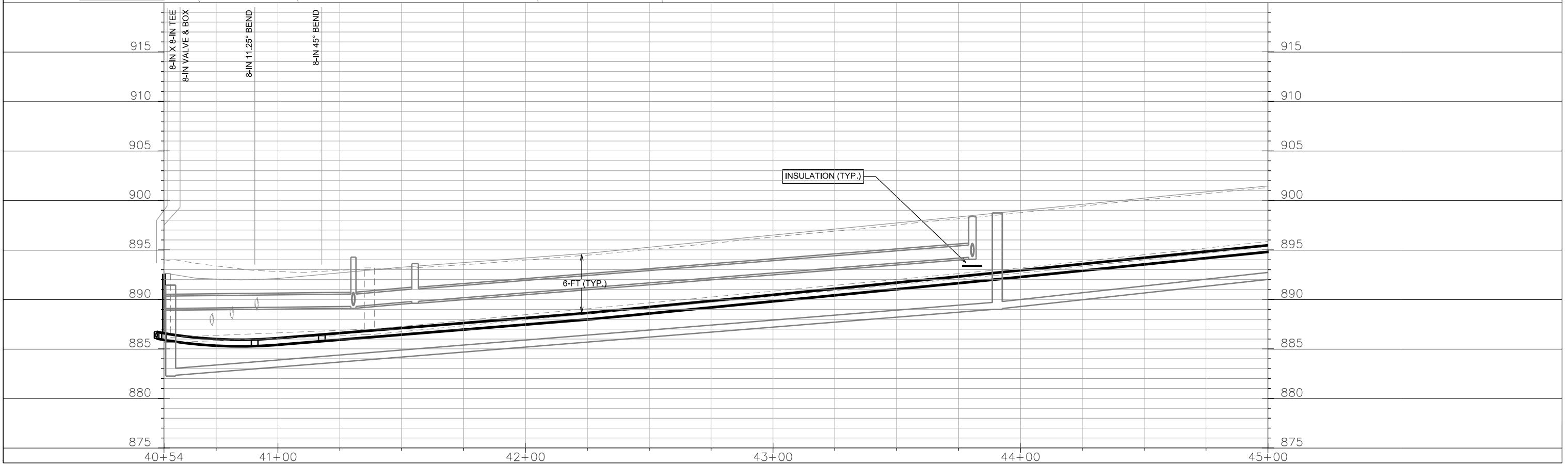
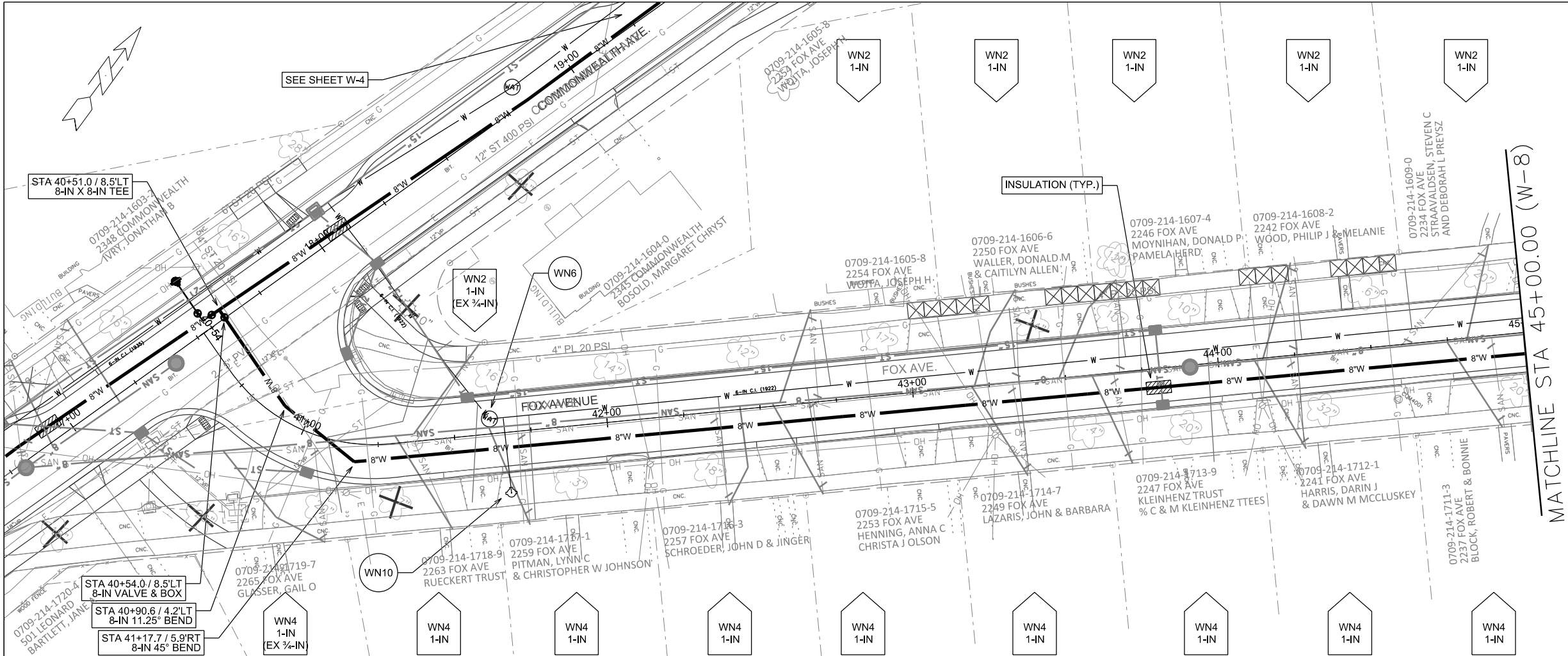

MATCHLINE STA 45+00.00 (W-8)

PLOT SCALE:

PLOT NAME:

REV. DATE:

ORIGINATOR: CITY OF MADISON, STREETS DIVISION

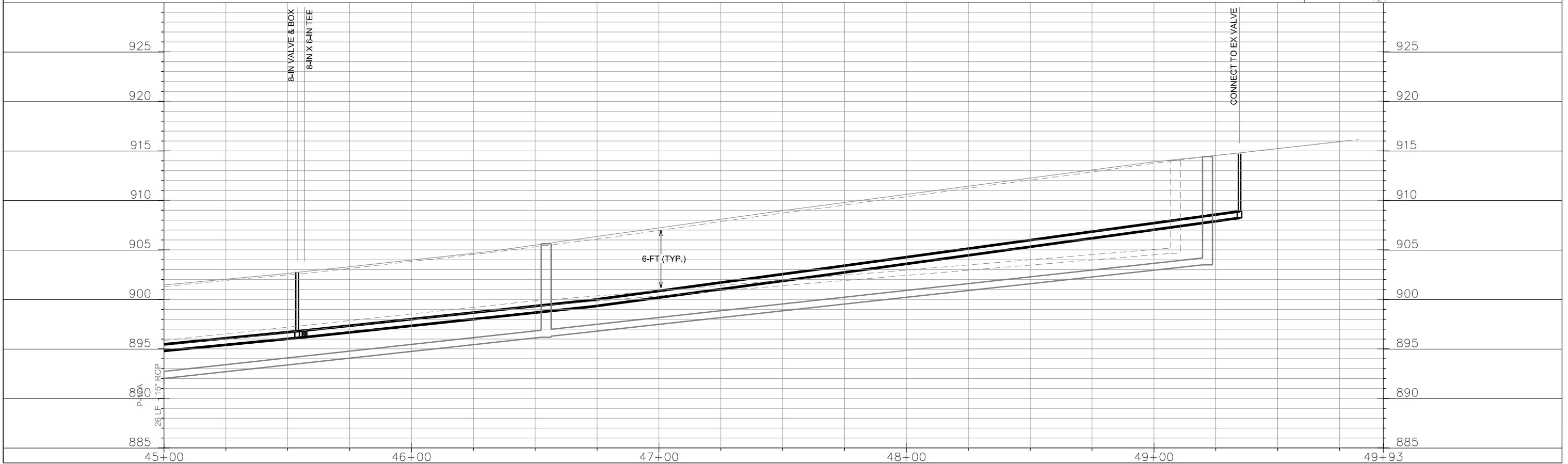
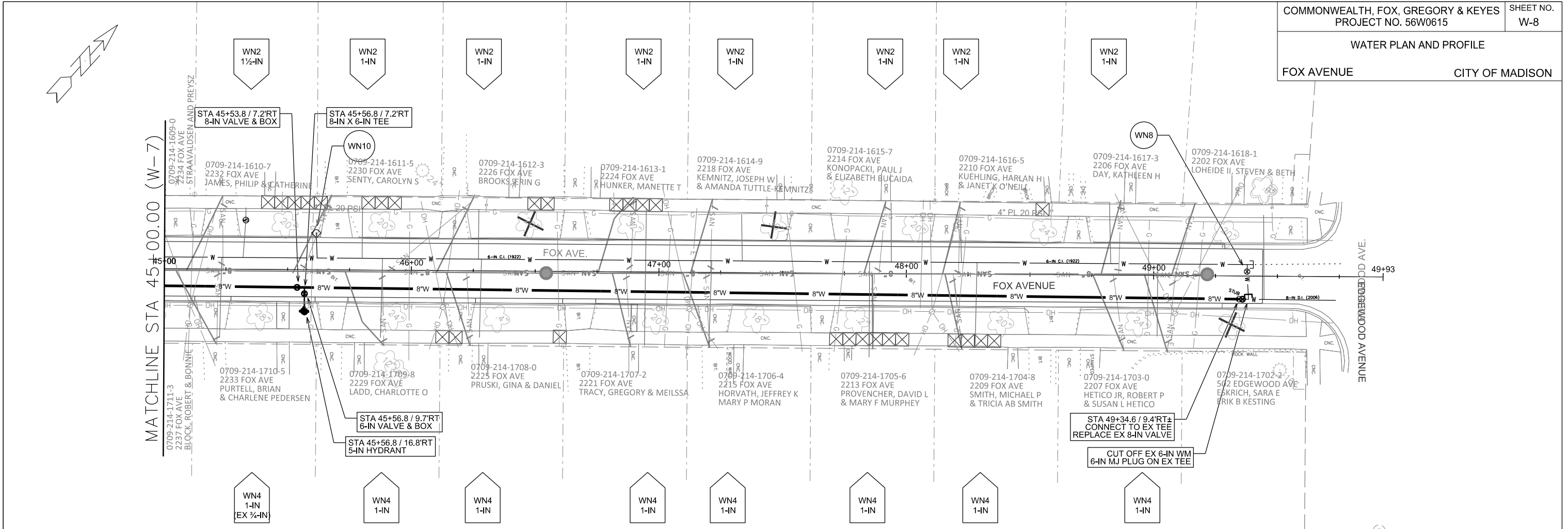

PLOT SCALE:

PLOT NAME:

REV. DATE:

ORIGINATOR: CITY OF MADISON, STREETS DIVISION

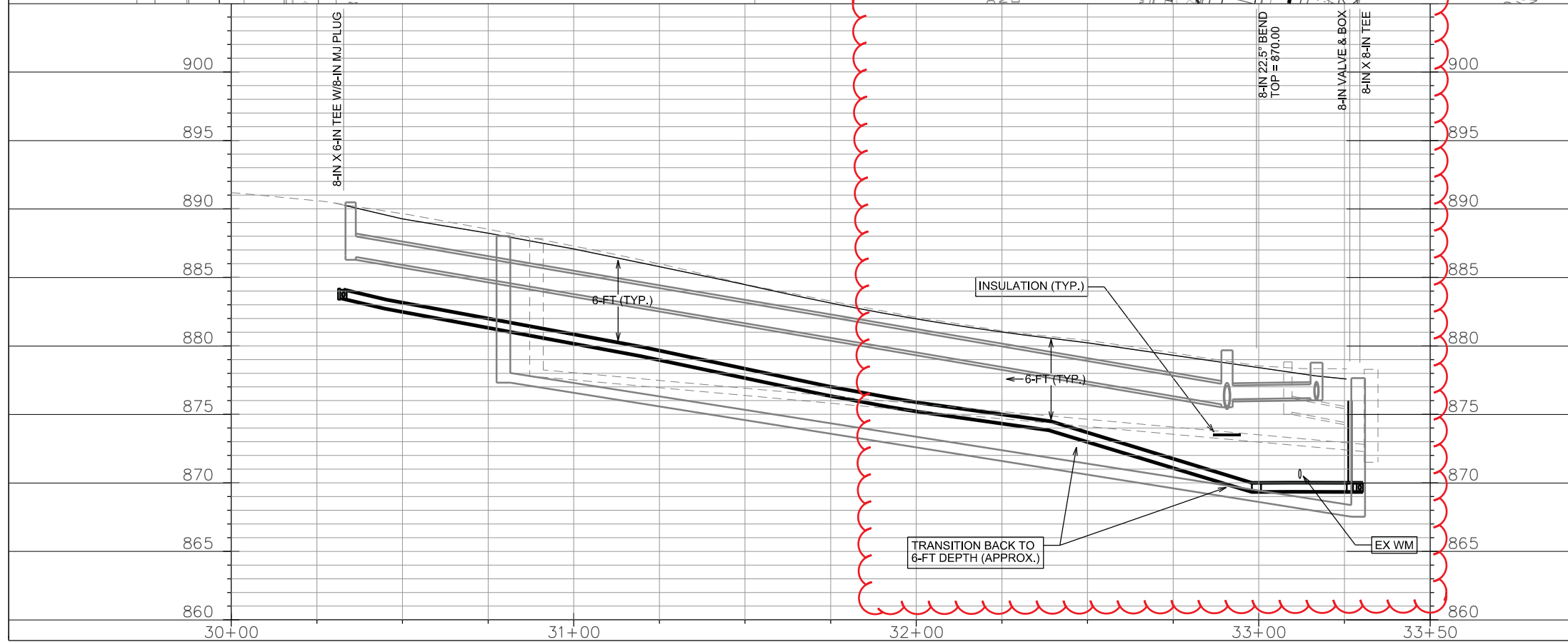
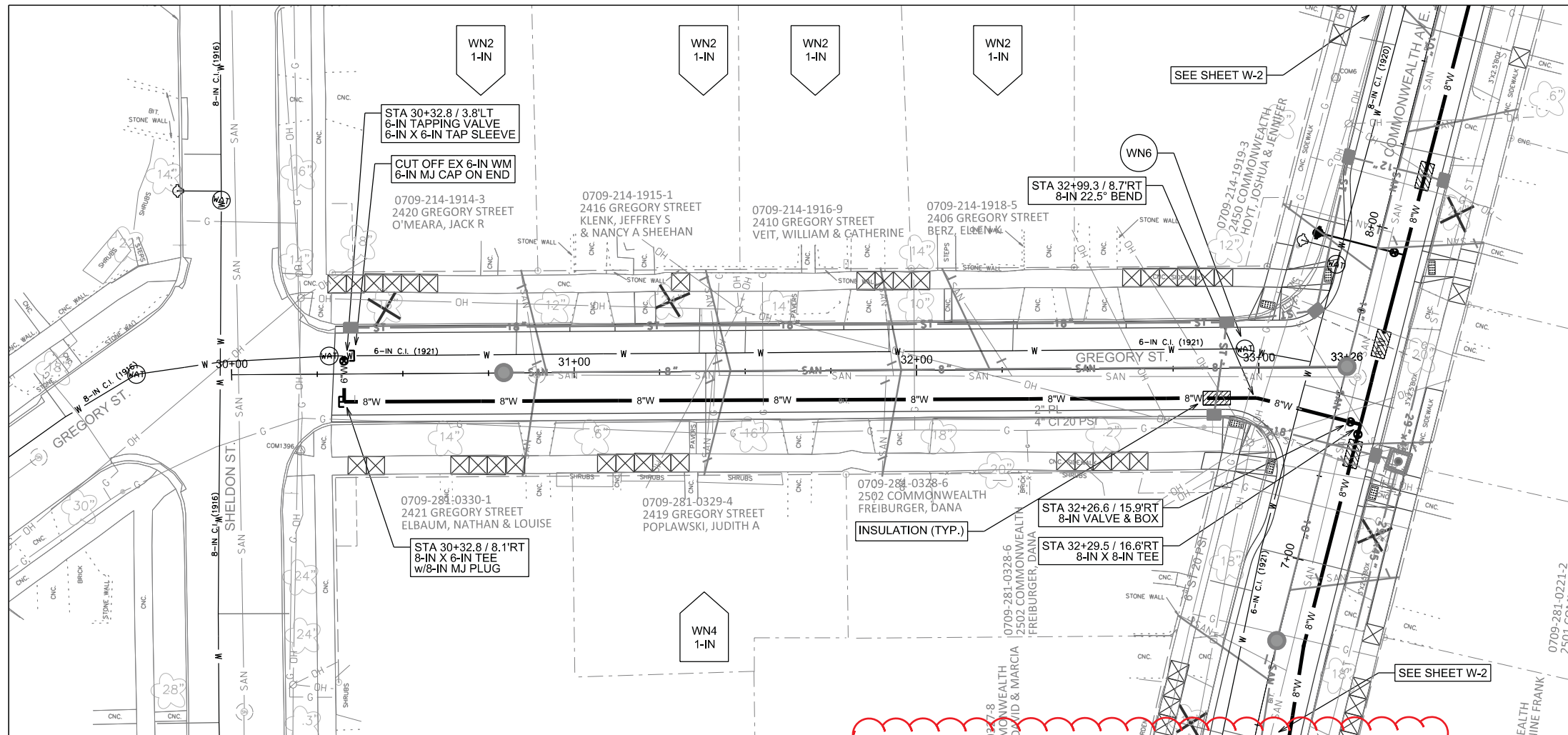

PLOT SCALE:

PLOT NAME:

REV. DATE:

ORIGINATOR: CITY OF MADISON, STREETS DIVISION

REV #1 05.23.2014

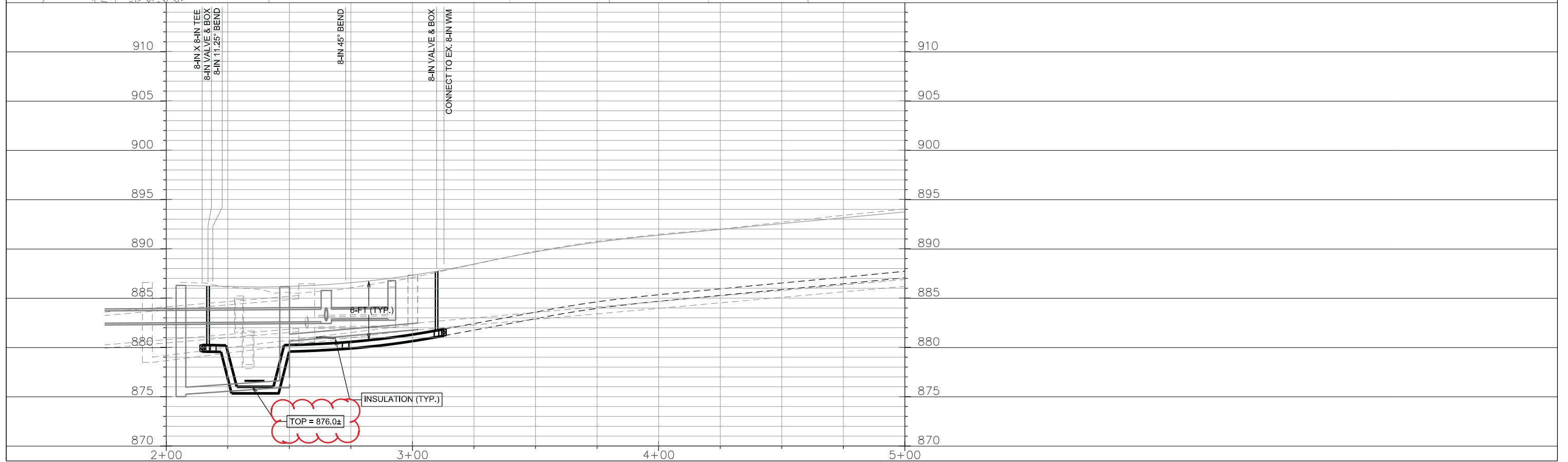
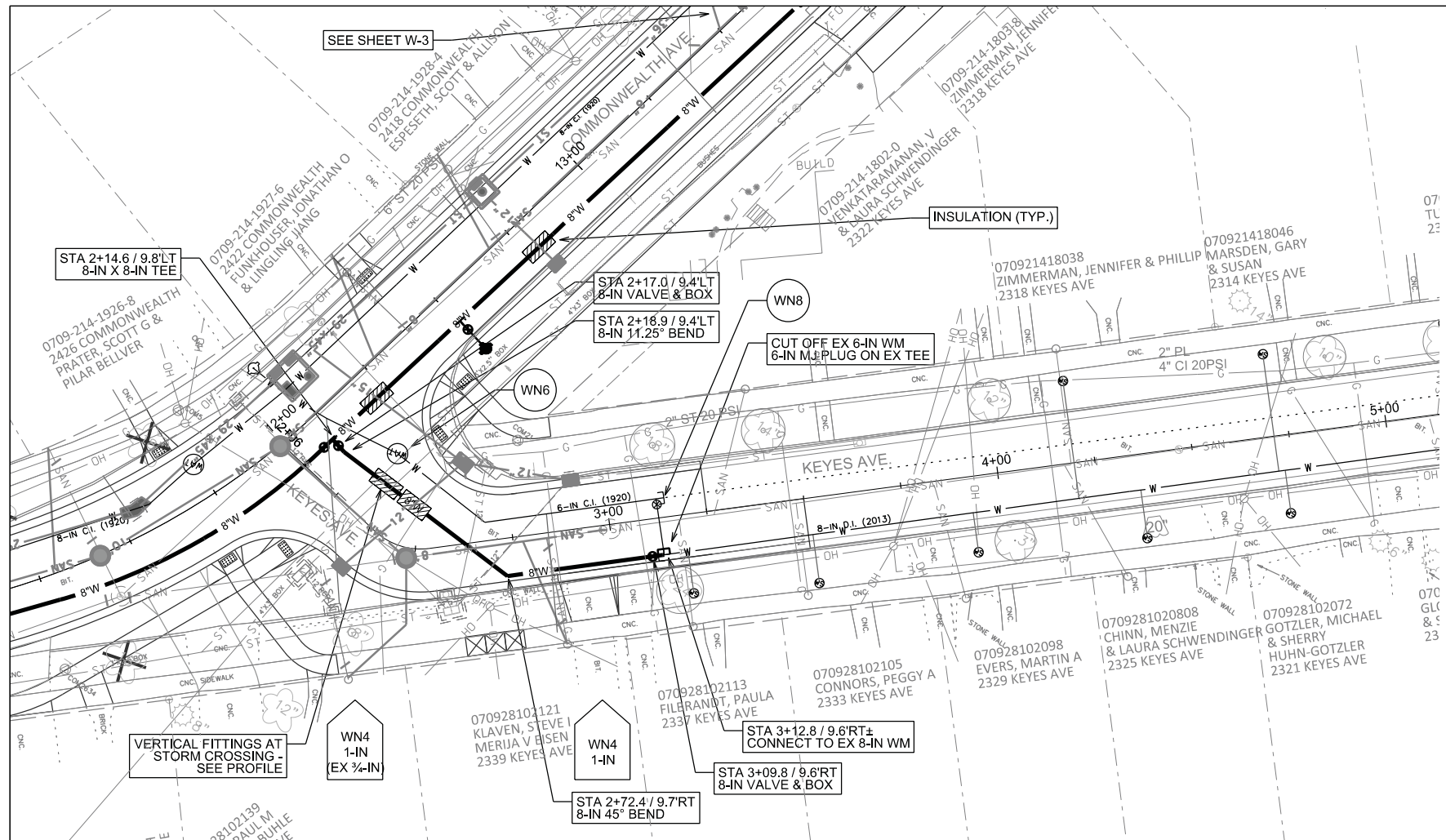

PLOT SCALE:

PLOT NAME:

REV. DATE:

ORIGINATOR: CITY OF MADISON, STREETS DIVISION

CONSTRUCTION NOTES:

1. CONSTRUCT NEW WATER MAIN 6.0' BELOW FINISHED GRADE, UNLESS OTHERWISE NOTED. INSULATE MAIN WITH POLYSTYRENE BOARD AT UTILITY CROSSINGS OR OTHER AREAS IDENTIFIED BY ENGINEER AS HAVING INADEQUATE COVER.
2. VERIFY SIZE OF EXISTING WATER SERVICES AND RECONNECT SERVICES AS INDICATED.
3. MINIMIZE DISTRUPTION OF SERVICE TO EXISTING CUSTOMERS. NOTIFY PER CONTRACT REQUIREMENTS OF ANY PLANNED WATER OUTAGE.
4. THE EXISTING UTILITIES SHOWN ON THIS PLAN REPRESENT THE BEST INFORMATION AVAILABLE TO THE WATER UTILITY AT THE TIME OF PLAN PREPARATION. CONTRACTOR IS RESPONSIBLE FOR HAVING EACH UTILITY LOCATED PRIOR TO COMMENCING WORK.

- WN1 REPLACE THE EXISTING LEAD SERVICE WITH A NEW COPPER SERVICE.
- WN2 EXTEND AND RECONNECT THE EXISTING COPPER SERVICE TO THE NEW WATER MAIN.
- WN3 EXISTING SERVICE TO BE ABANDONED WHEN THE WATER MAIN IS CUT OFF.
- WN4 DISCONNECT FROM THE OLD WATER MAIN AND RECONNECT THE EXISTING COPPER WATER SERVICE LATERAL TO THE NEW WATER MAIN.
- WN5 RELOCATE THE EXISTING FIRE HYDRANT.
- WN6 ABANDON WATER VALVE ACCESS STRUCTURE.
- WN7 FURNISH AND INSTALL THE NEW TOP SECTION FOR THE WATER ACCESS STRUCTURE.
- WN8 ABANDON THE VALVE BOX.
- WN9 FURNISH THE DITCH, COMPACTION, AND ALL MATERIALS AND LABOR FOR THE INSTALLATION OF NEW SERVICE LATERAL.
- WN10 REMOVE AND SALVAGE EXISTING HYDRANT
- WN11 REPLACE THE EXISTING COPPER SERVICE WITH A COPPER SERVICE

TO OBTAIN LOCATION OF PARTICIPANTS' UNDERGROUND FACILITIES BEFORE YOU DIG IN WISCONSIN

CALL DIGGERS HOTLINE
TOLL FREE
811 OR 1-800-242-9511
FAX-A-LOCATE 1-800-338-3860
TDD (FOR HEARING IMPAIRED) 1-800-542-2289

WIS. STATUTE 182.0175 (1974)
REQUIRES MIN. OF 3 WORK DAYS
NOTICE BEFORE YOU EXCAVATE.

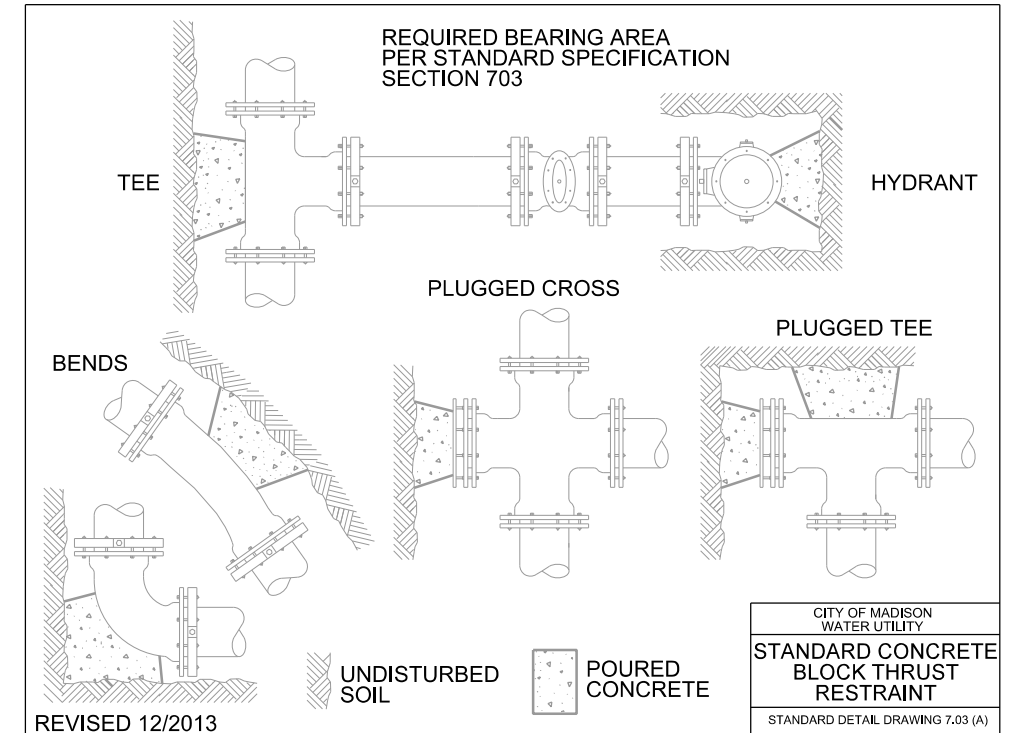
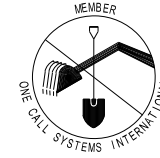

MATERIALS SUPPLIED BY CONTRACTOR*:

- | | |
|-----------------------------|------------------------------------|
| 200-FT - 6-IN PIPE | 2 - 8-IN 11.25° BEND |
| 4,000-FT - 8-IN PIPE | 2 - 8-IN 22.5° BEND |
| | 19 - 8-IN 45° BEND |
| 4,620-FT - POLYWRAP | 1 - 6-IN 90° BEND |
| 9 - 6-IN VALVE & BOX | 3 - 6-IN MJ PLUG |
| 12 - 8-IN VALVE & BOX | 4 - 8-IN MJ PLUG |
| 1 - 6-IN X 6-IN TEE | 4 - 6-IN MJ CAP |
| 10 - 8-IN X 6-IN TEE | 160-FT - 2-IN STYROFOAM INSULATION |
| 6 - 8-IN X 8-IN TEE | COPPER - 1-IN AS REQ'D |
| 1 - 8-IN X 6-IN CROSS | |
| 7 - 5-IN HYDRANTS | |
| TEMPORARY HYDRANTS AS REQ'D | |

MATERIALS SUPPLIED BY CITY*:

- 3 - 6-IN TAPPING VALVE
- 3 - 6-IN X 6-IN TAP SLEEVE

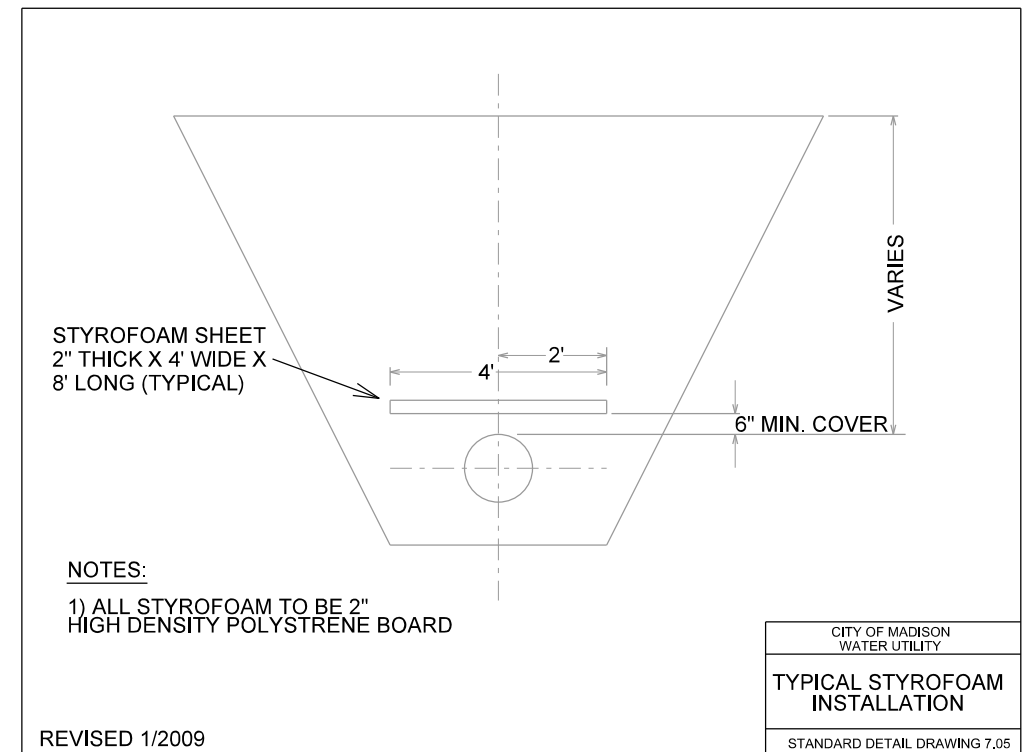
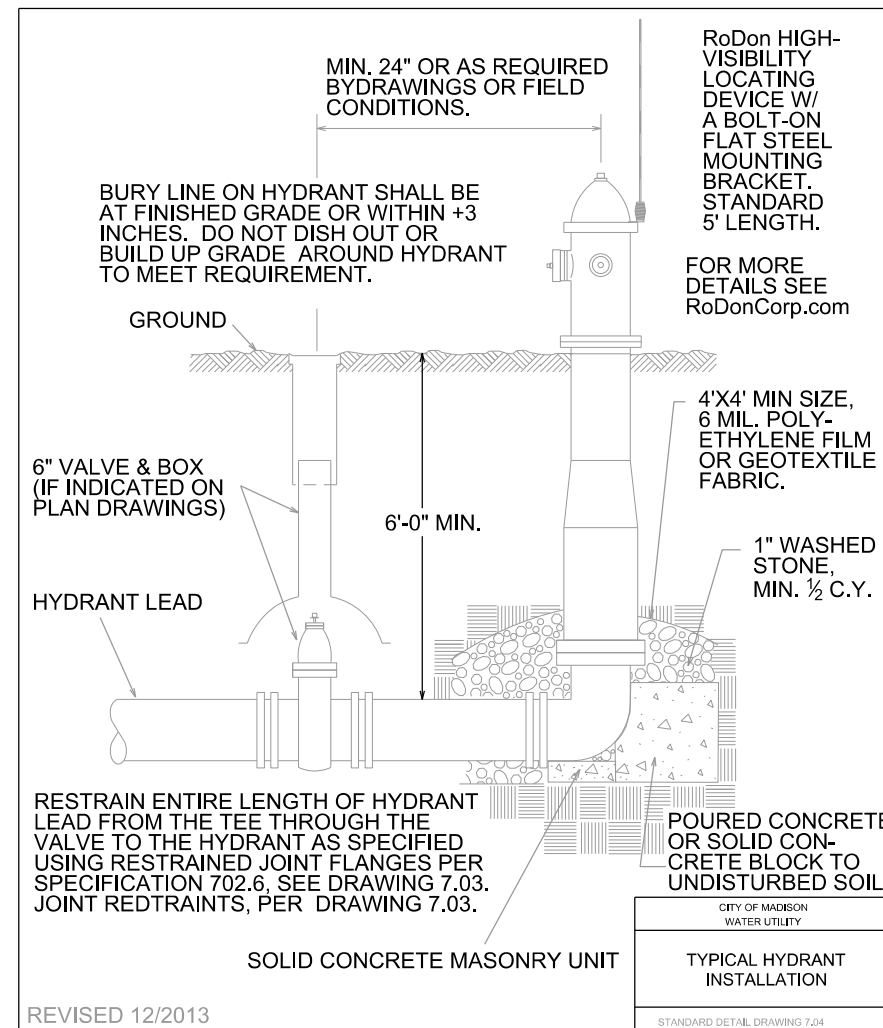

* ESTIMATES FOR INFORMATION ONLY. ENGINEER DOES NOT GUARANTEE ACCURACY OF MATERIAL TAKE-OFFS.

CUT OFF & CAP EX WM
 -TURN VALVES:
 *V-3 *V-4
 -NOTIFY:
 *GREGORY ST
 (2406-2420)

CUT OFF & CAP EX WM
 -TURN VALVES:
 *V-4 *V-5 *V-9
 -NOTIFY:
 *COMMONWEALTH AVE
 (2459, 2501-2559)

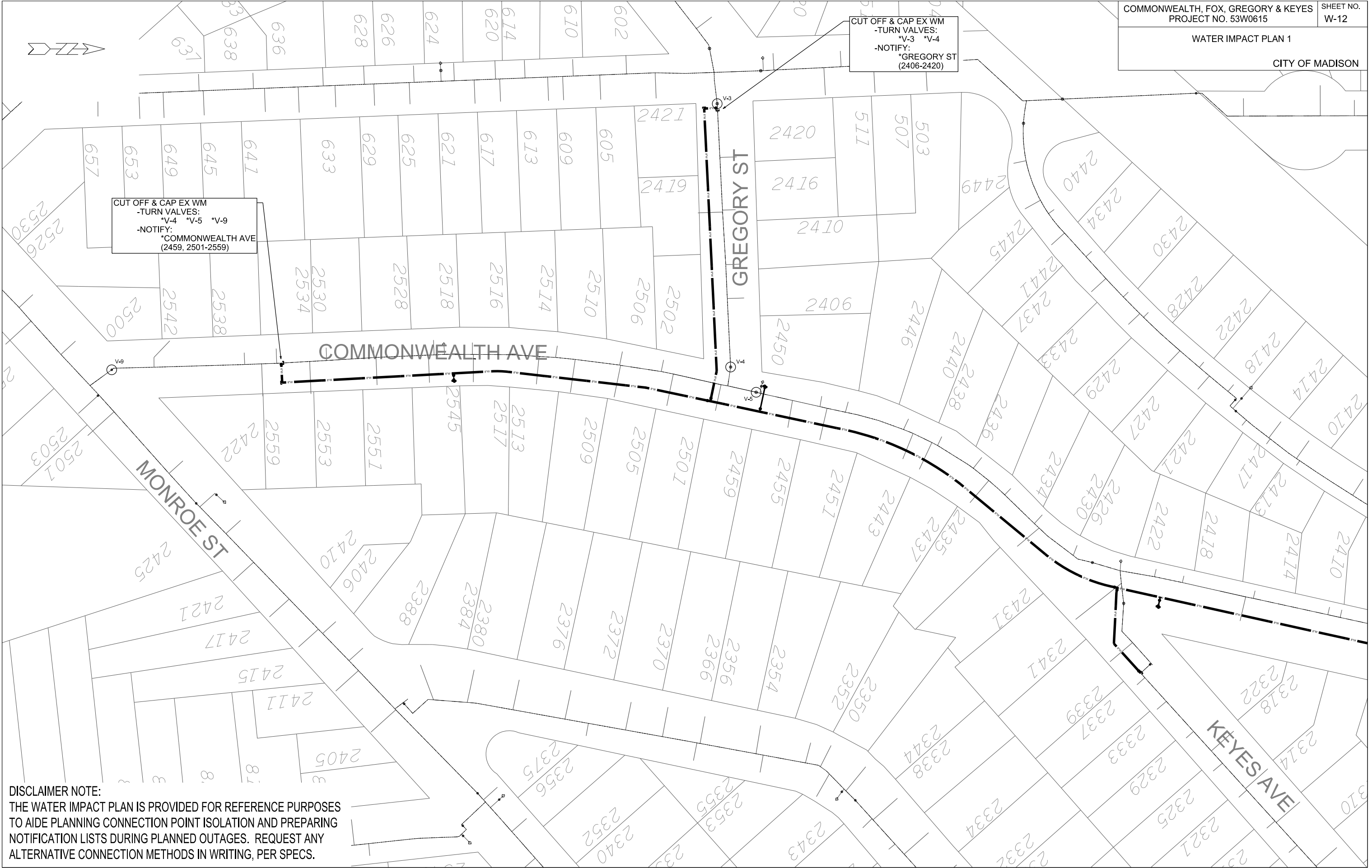

DISCLAIMER NOTE:
 THE WATER IMPACT PLAN IS PROVIDED FOR REFERENCE PURPOSES TO AIDE PLANNING CONNECTION POINT ISOLATION AND PREPARING NOTIFICATION LISTS DURING PLANNED OUTAGES. REQUEST ANY ALTERNATIVE CONNECTION METHODS IN WRITING, PER SPECS.

PLOT SCALE:

PLOT NAME:

REV. DATE:

ORIGINATOR: CITY OF MADISON, STREETS DIVISION

FILE NAME:

DATE:

WATER IMPACT PLAN 2

CITY OF MADISON

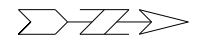

PLOT SCALE:

PLOT NAME:

REV. DATE:

ORIGINATOR: CITY OF MADISON, STREETS DIVISION

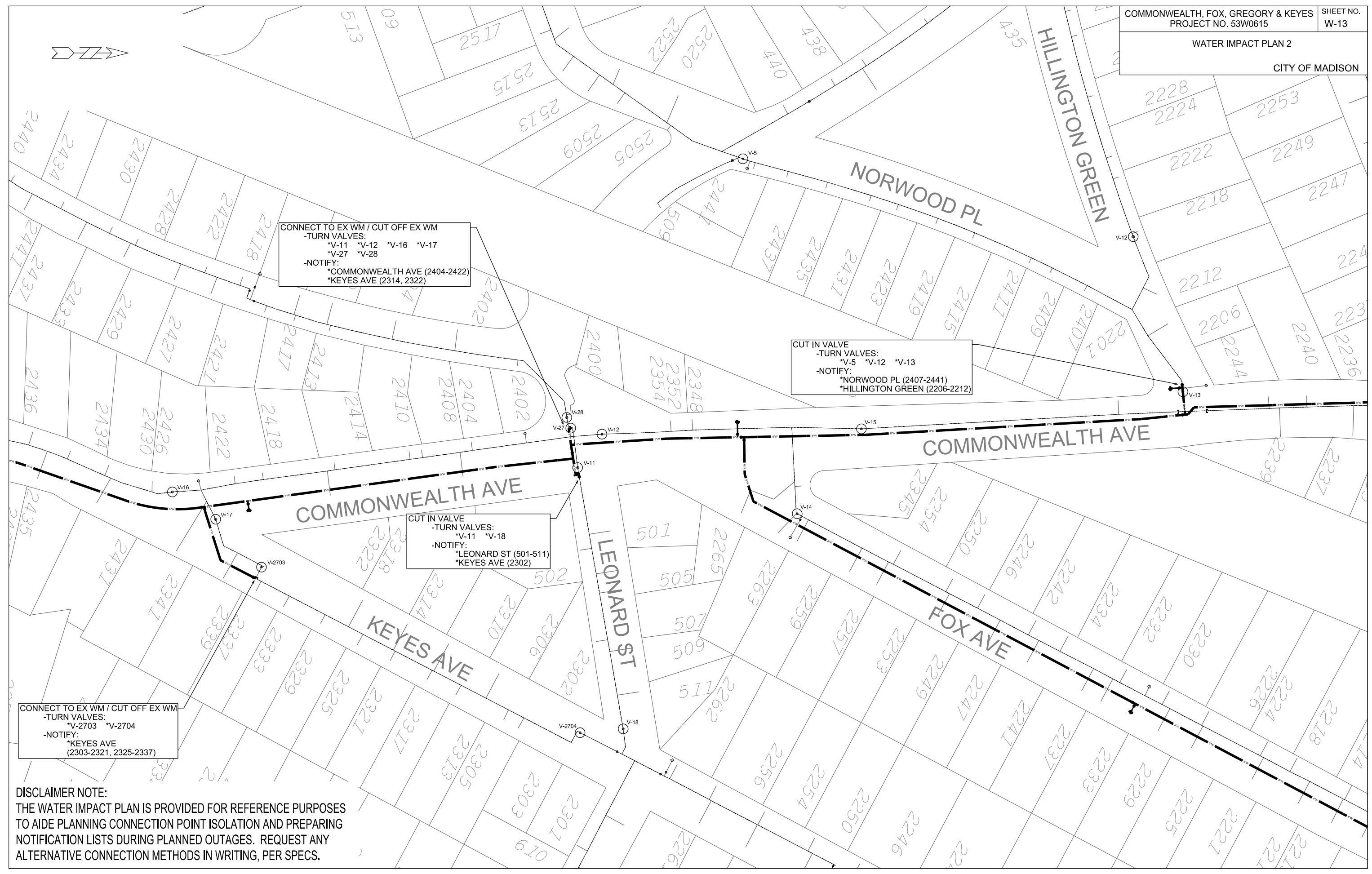

CONNECT TO EX WM / CUT OFF EX WM
-TURN VALVES:
*V-11 *V-12 *V-16 *V-17
*V-27 *V-28
-NOTIFY:
*COMMONWEALTH AVE (2404-2422)
*KEYES AVE (2314, 2322)

CUT IN VALVE
-TURN VALVES:
*V-5 *V-12 *V-13
-NOTIFY:
*NORWOOD PL (2407-2441)
*HILLINGTON GREEN (2206-2212)

CUT IN VALVE
-TURN VALVES:
*V-11 *V-18
-NOTIFY:
*LEONARD ST (501-511)
*KEYES AVE (2302)

CONNECT TO EX WM / CUT OFF EX WM
-TURN VALVES:
*V-2703 *V-2704
-NOTIFY:
*KEYES AVE
(2303-2321, 2325-2337)

DISCLAIMER NOTE:
THE WATER IMPACT PLAN IS PROVIDED FOR REFERENCE PURPOSES
TO AIDE PLANNING CONNECTION POINT ISOLATION AND PREPARING
NOTIFICATION LISTS DURING PLANNED OUTAGES. REQUEST ANY
ALTERNATIVE CONNECTION METHODS IN WRITING, PER SPECS.

FILE NAME:

DATE:

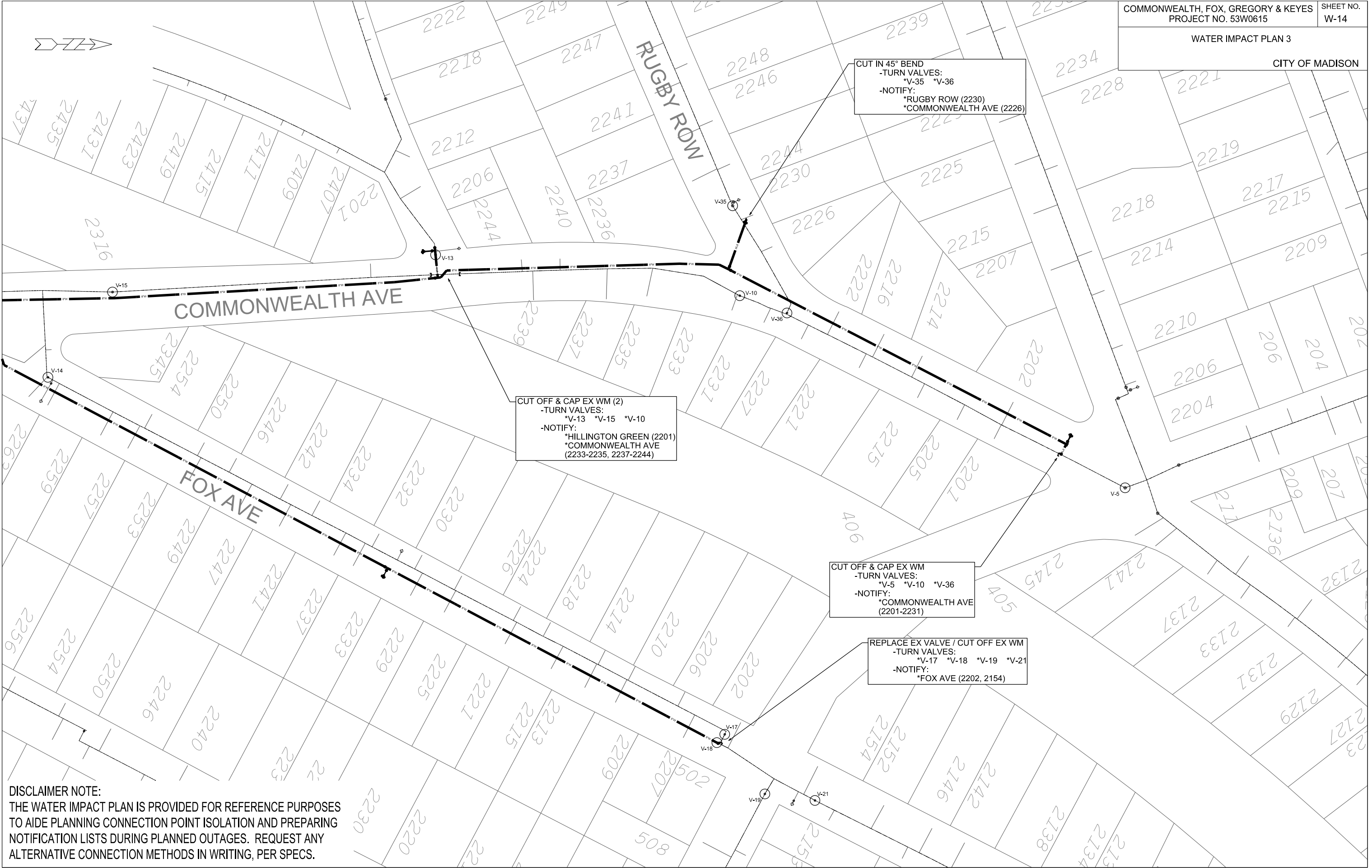
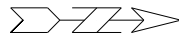

CUT IN 45° BEND
-TURN VALVES:
*V-35 *V-36
-NOTIFY:
*RUGBY ROW (2230)
*COMMONWEALTH AVE (2226)

CUT OFF & CAP EX WM (2)
-TURN VALVES:
*V-13 *V-15 *V-10
-NOTIFY:
*HILLINGTON GREEN (2201)
*COMMONWEALTH AVE
(2233-2235, 2237-2244)

CUT OFF & CAP EX WM
-TURN VALVES:
*V-5 *V-10 *V-36
-NOTIFY:
*COMMONWEALTH AVE
(2201-2231)

REPLACE EX VALVE / CUT OFF EX WM
-TURN VALVES:
*V-17 *V-18 *V-19 *V-21
-NOTIFY:
*FOX AVE (2202, 2154)

DISCLAIMER NOTE:
THE WATER IMPACT PLAN IS PROVIDED FOR REFERENCE PURPOSES
TO AIDE PLANNING CONNECTION POINT ISOLATION AND PREPARING
NOTIFICATION LISTS DURING PLANNED OUTAGES. REQUEST ANY
ALTERNATIVE CONNECTION METHODS IN WRITING, PER SPECS.

PLOT SCALE:

PLOT NAME:

REV. DATE:

ORIGINATOR: CITY OF MADISON, STREETS DIVISION

FILE NAME:

DATE:

PAVEMENT MARKING PLAN

COMMONWEALTH AVENUE CITY OF MADISON

PLOT SCALE:

PLOT NAME:

REV. DATE:

ORIGINATOR: CITY OF MADISON, TRAFFIC ENG. DIV.

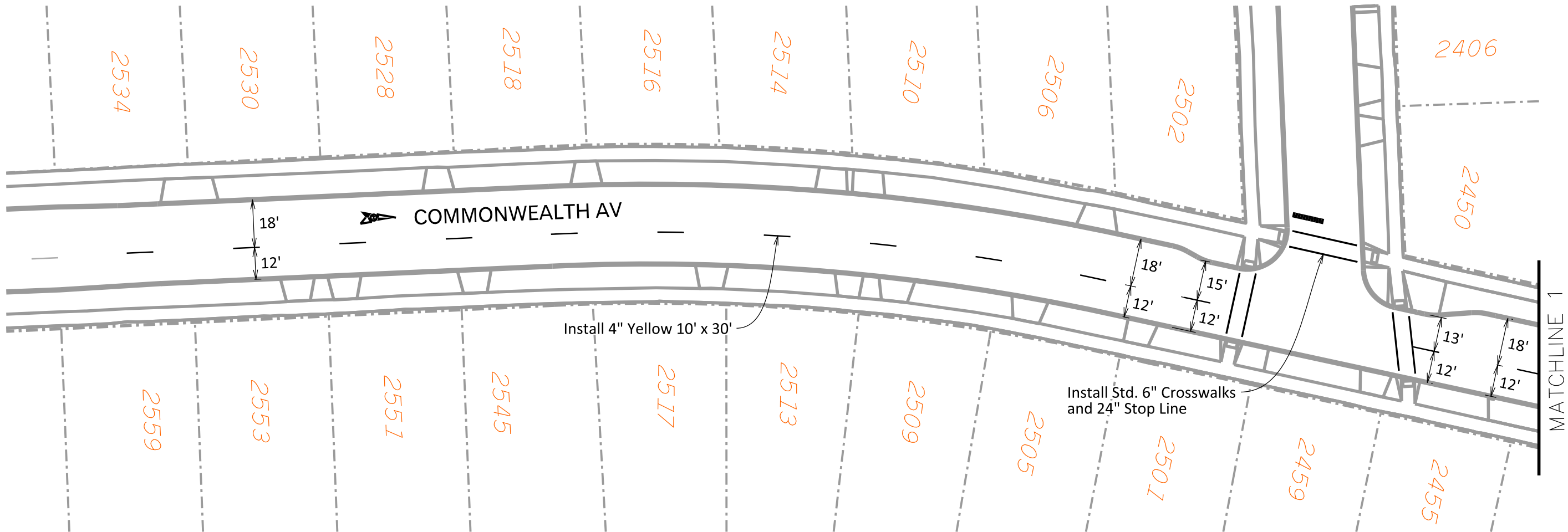

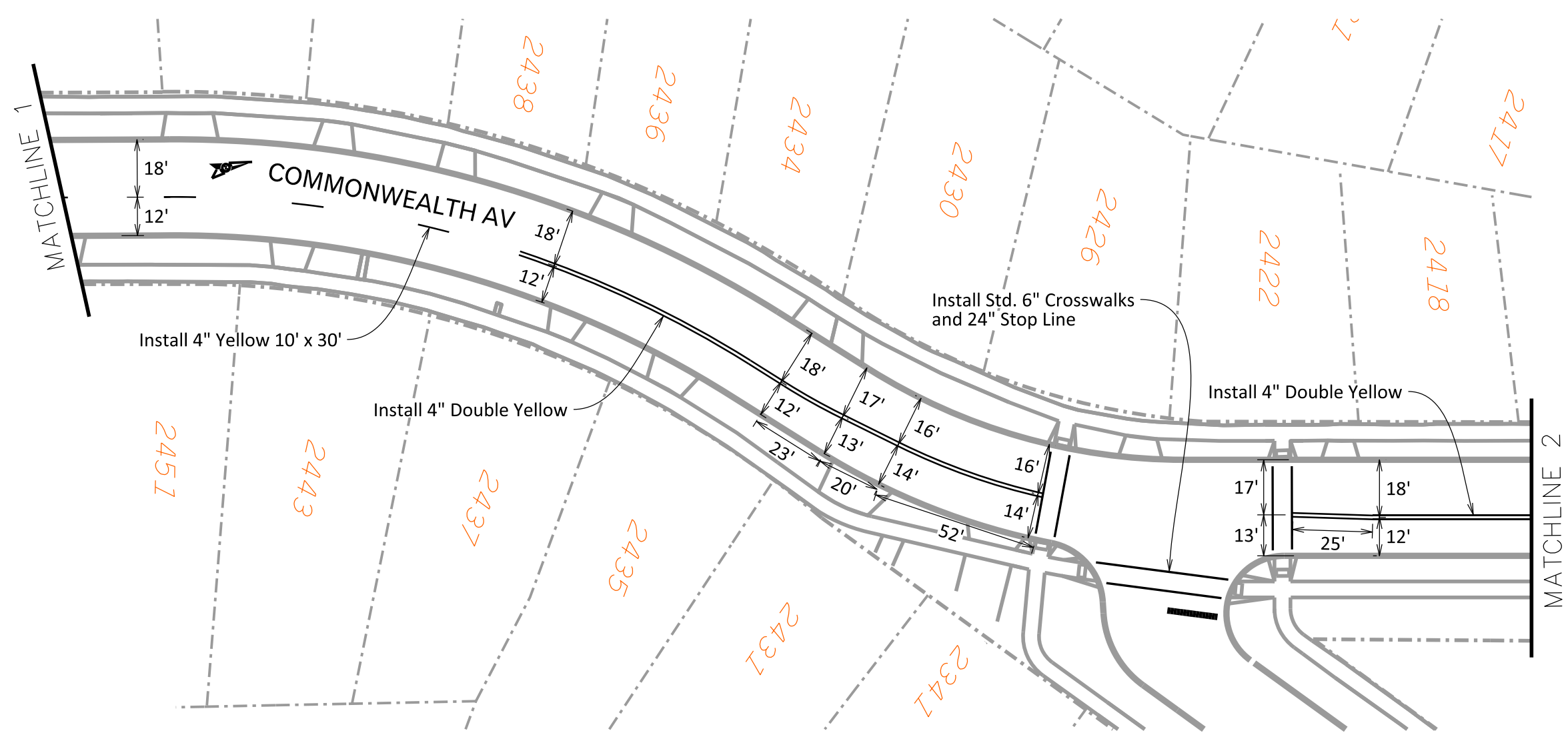

PLOT SCALE:
PLOT NAME:
REV. DATE:
ORIGINATOR: CITY OF MADISON, TRAFFIC ENG. DIV.

PAVEMENT MARKING PLAN

COMMONWEALTH AVENUE CITY OF MADISON

PLOT SCALE:

PLOT NAME:

REV. DATE:

ORIGINATOR: CITY OF MADISON, TRAFFIC ENG. DIV.

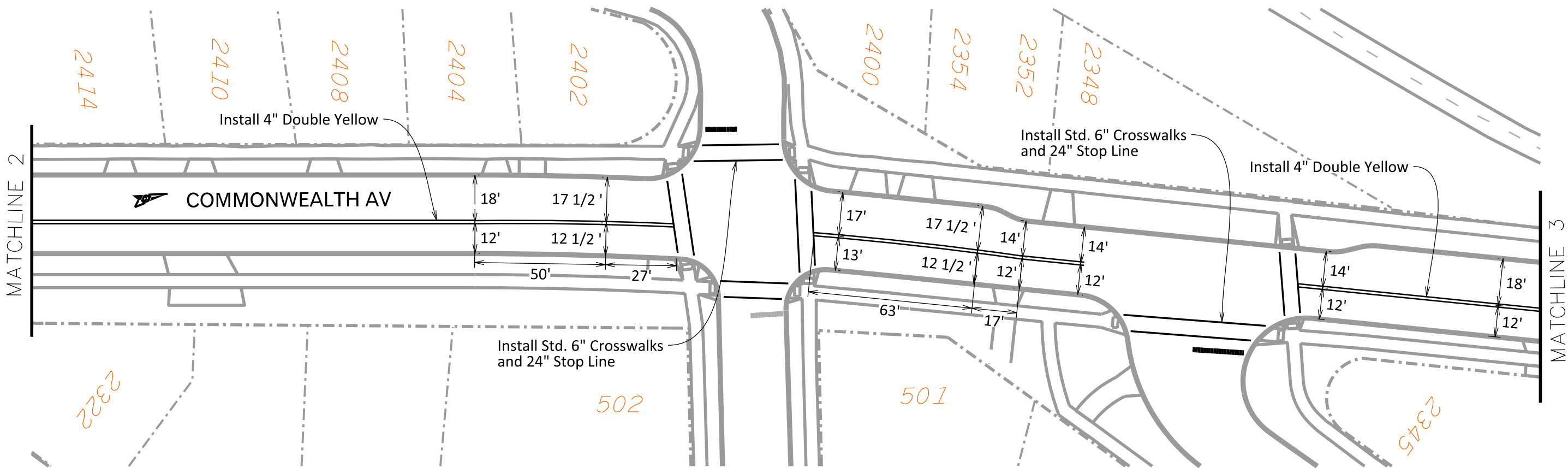

PAVEMENT MARKING PLAN

COMMONWEALTH AVENUE CITY OF MADISON

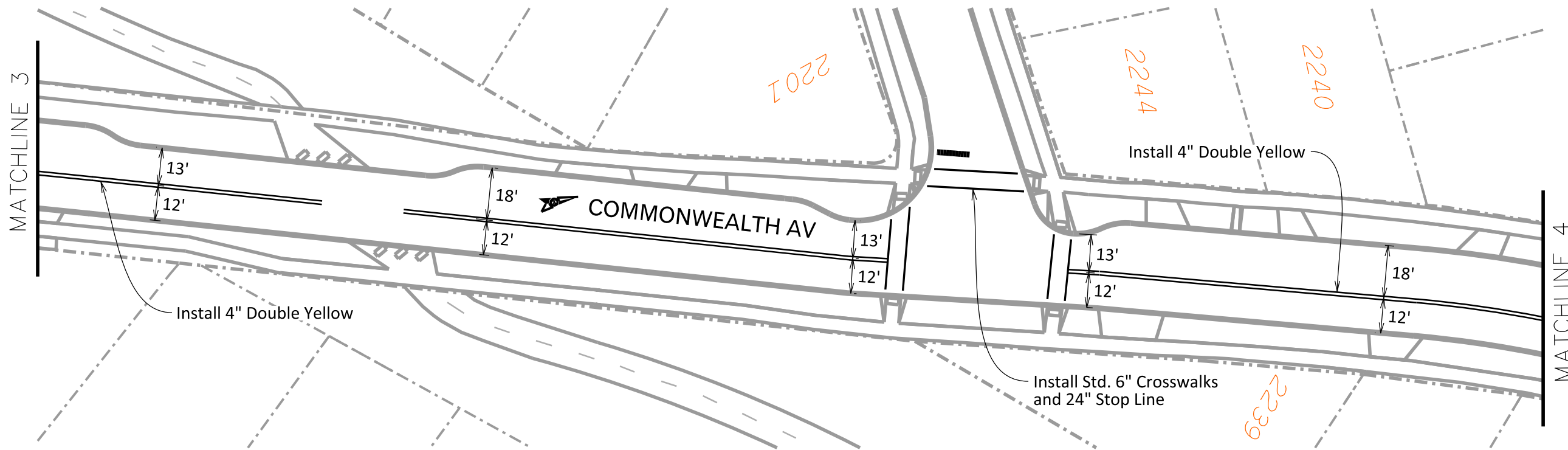

PLOT SCALE:

PLOT NAME:

REV. DATE:

ORIGINATOR: CITY OF MADISON, TRAFFIC ENG. DIV.

PAVEMENT MARKING PLAN

COMMONWEALTH AVENUE CITY OF MADISON

PLOT SCALE:

PLOT NAME:

REV. DATE:

ORIGINATOR: CITY OF MADISON, TRAFFIC ENG. DIV.

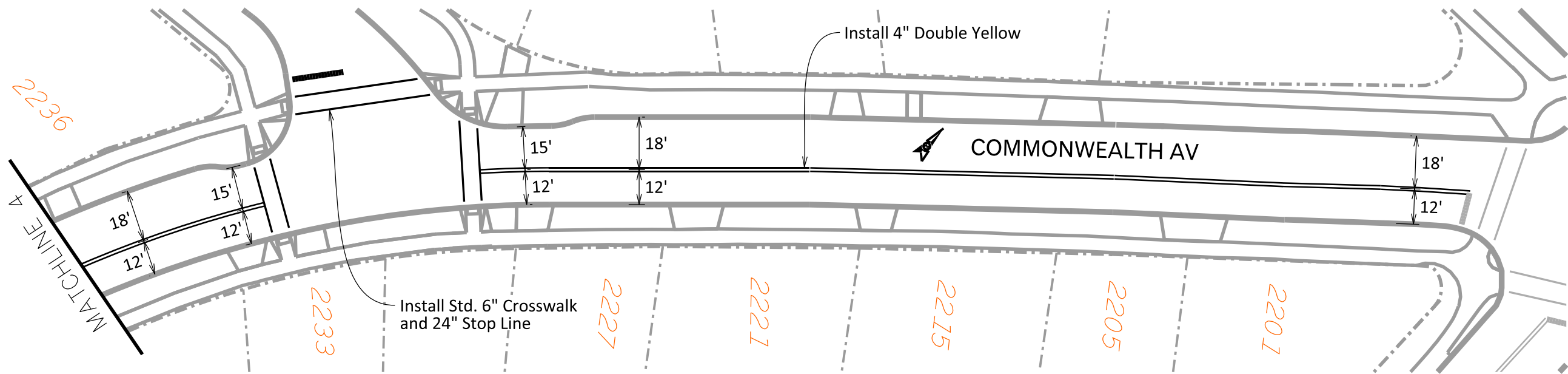

CROSS SECTIONS
COMMONWEALTH AVENUE CITY OF MADISON

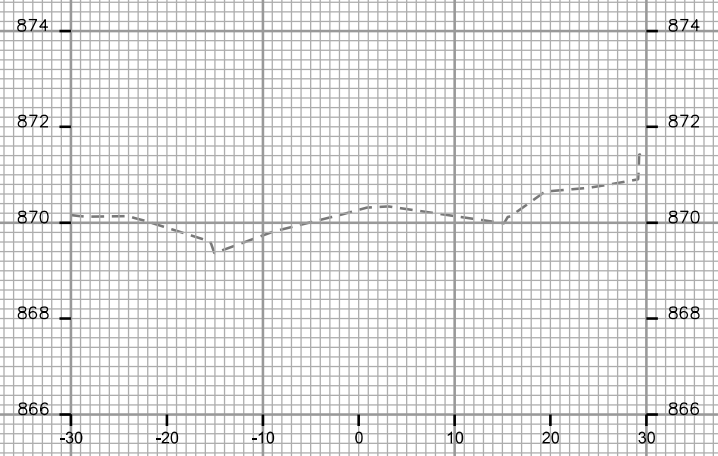

STA. 2+50

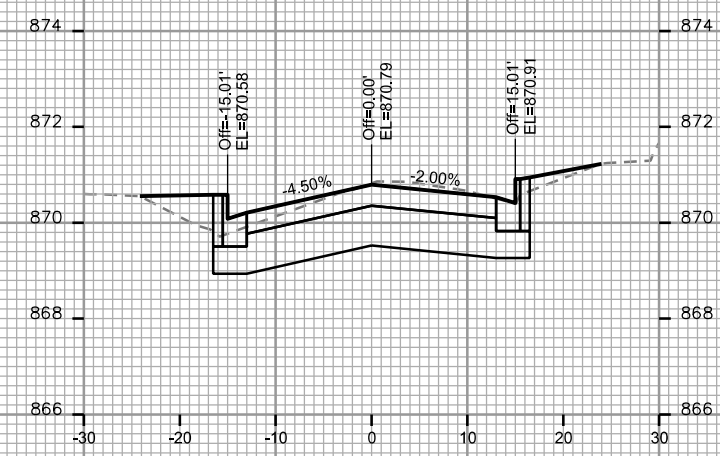

STA. 3+25

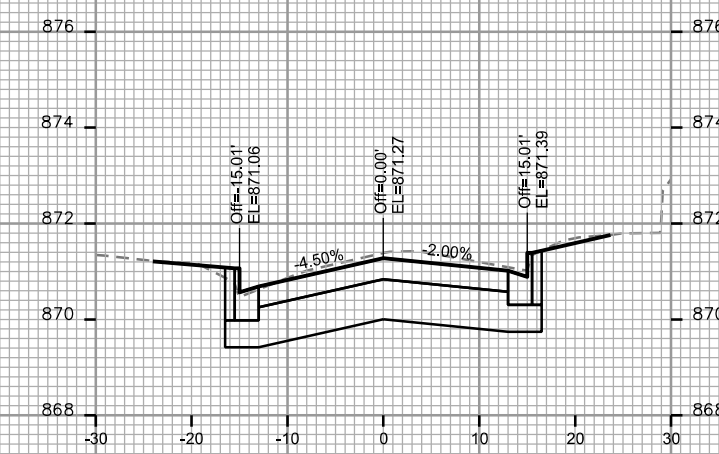

STA. 4+00

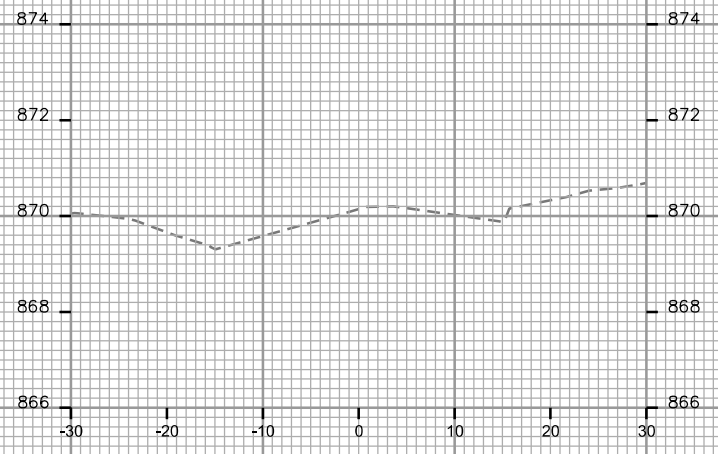

STA. 2+25

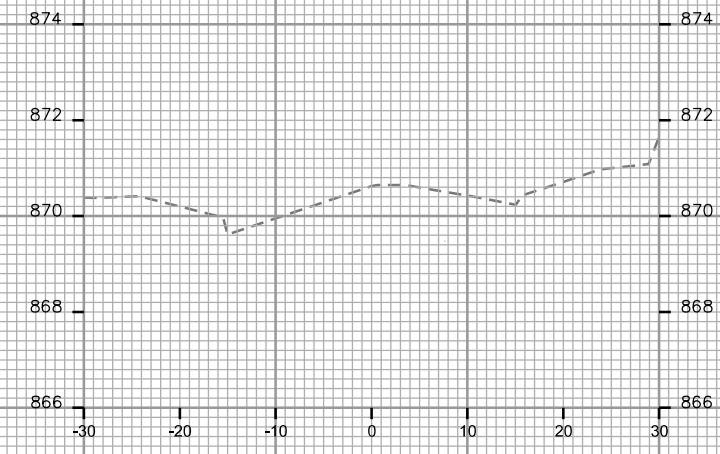

STA. 3+00

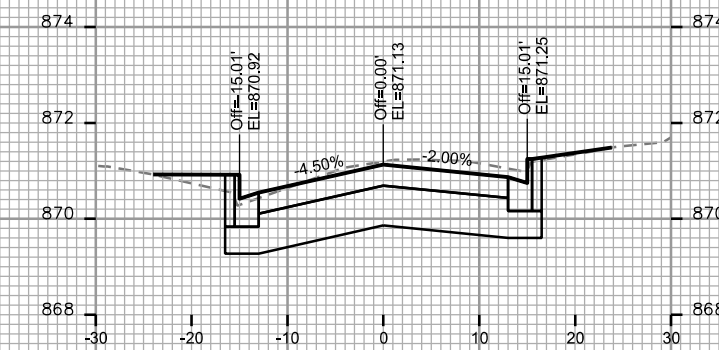

STA. 3+75

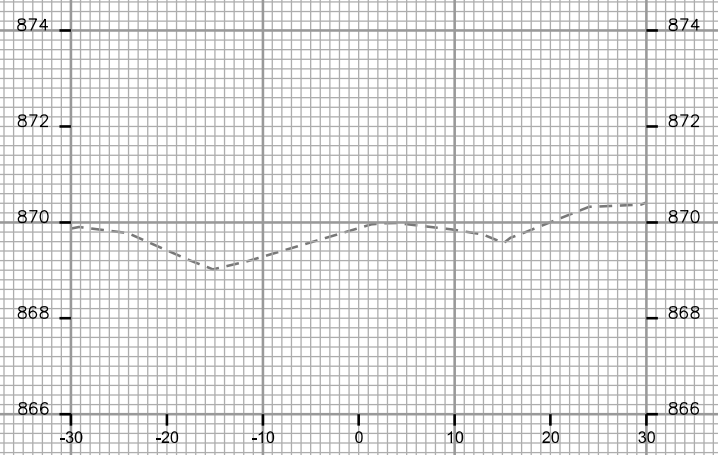

STA. 2+00

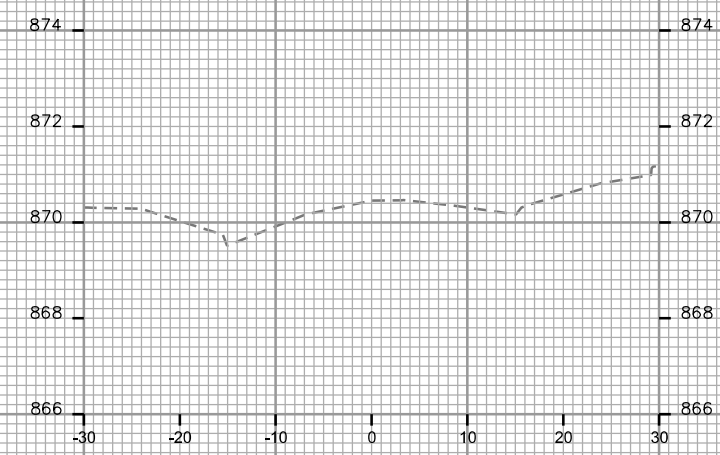

STA. 2+75

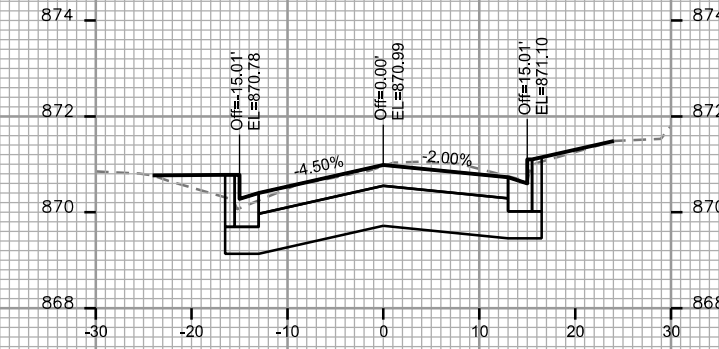

STA. 3+50

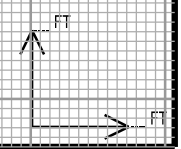

PLOT SCALE: _____

PLOT NAME: _____

REV. DATE: _____

ORIGINATOR: CITY OF MADISON, STREETS DIVISION

CROSS SECTIONS
COMMONWEALTH AVENUE CITY OF MADISON

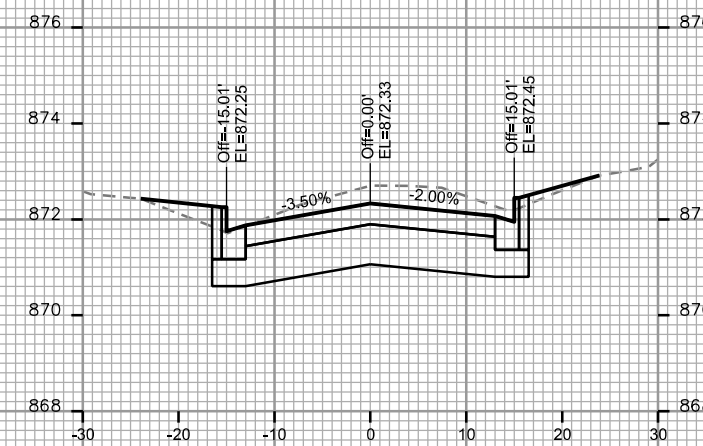
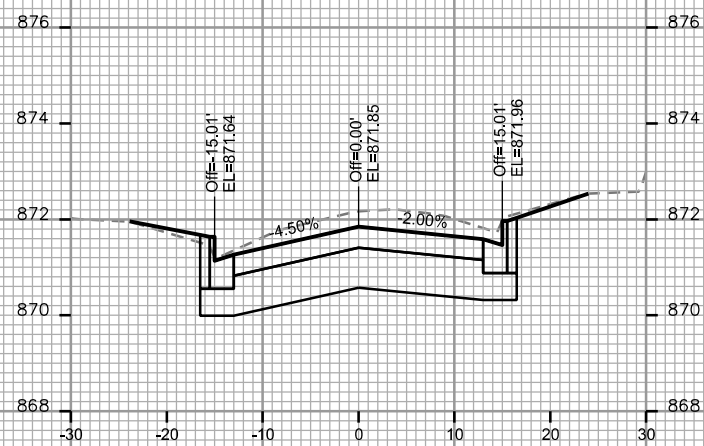
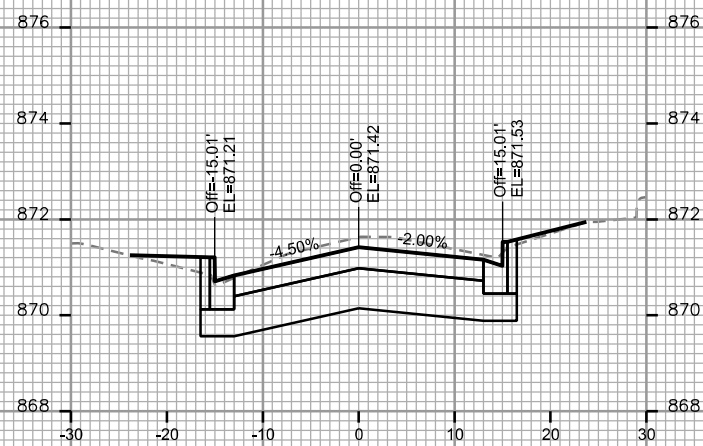
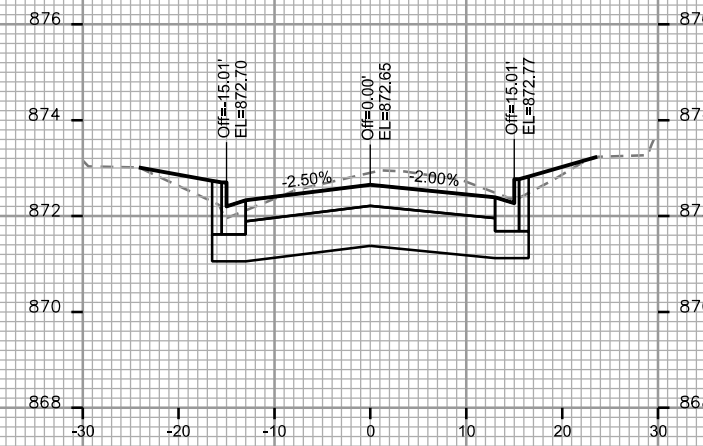
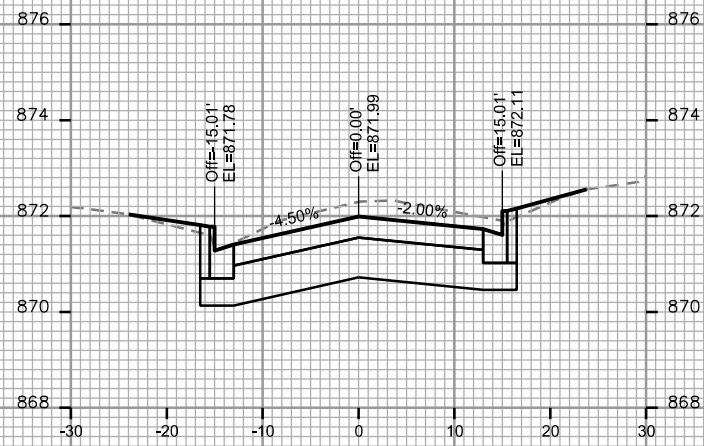
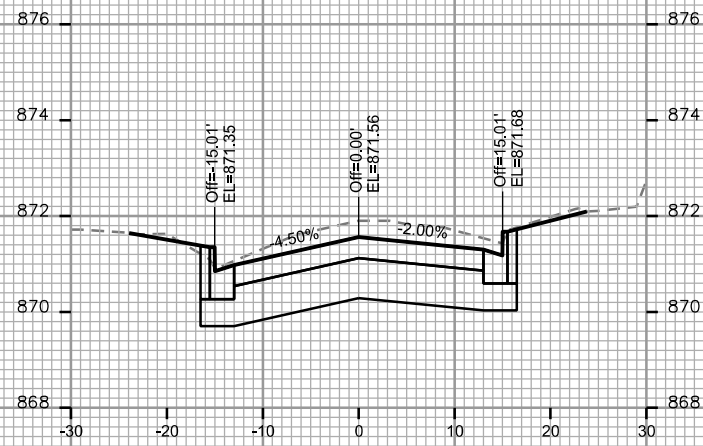
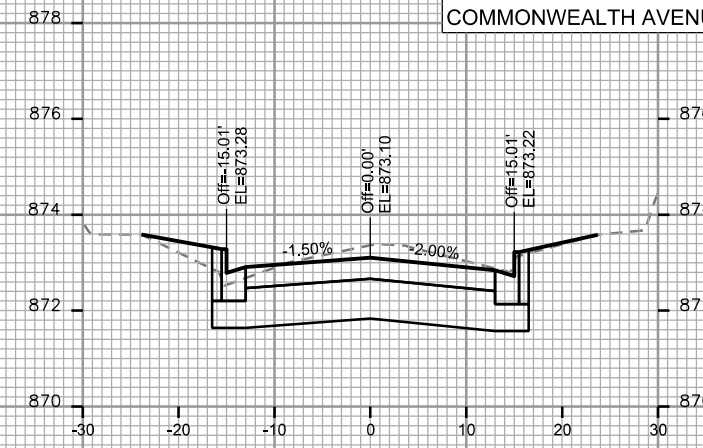
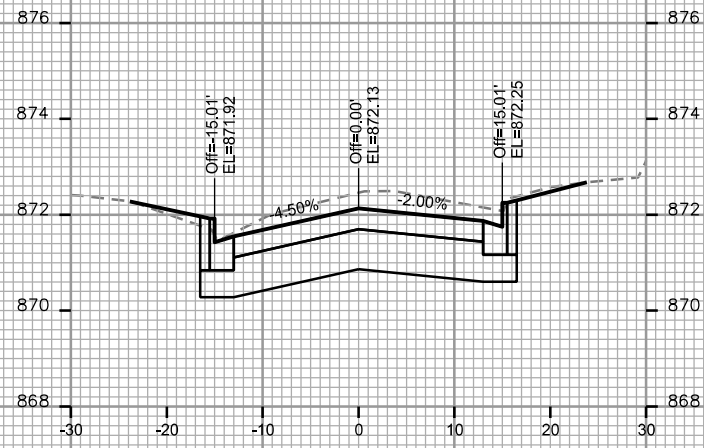
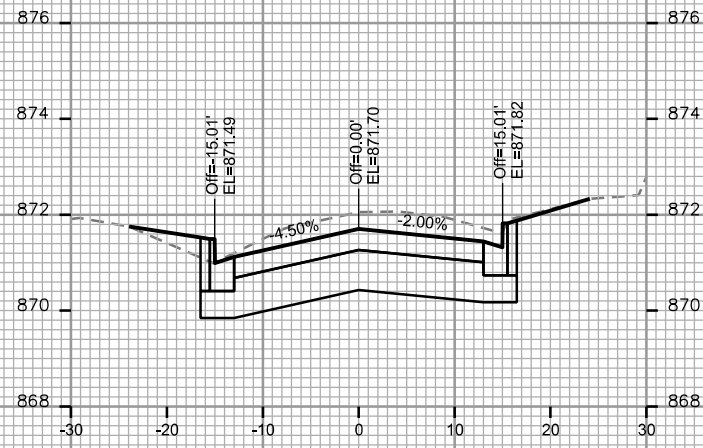

PLOT SCALE: _____

PLOT NAME: _____

REV. DATE: _____

ORIGINATOR: CITY OF MADISON - STREETS DIVISION

CROSS SECTIONS
COMMONWEALTH AVENUE CITY OF MADISON

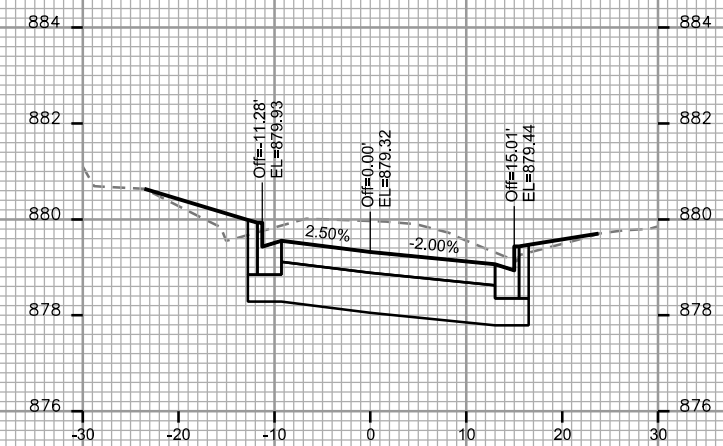
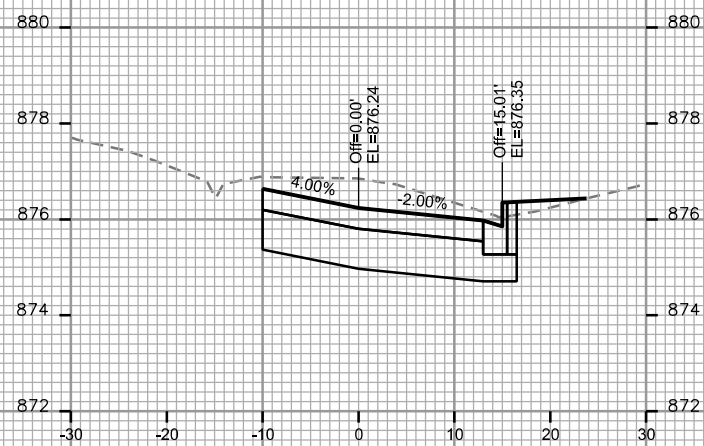
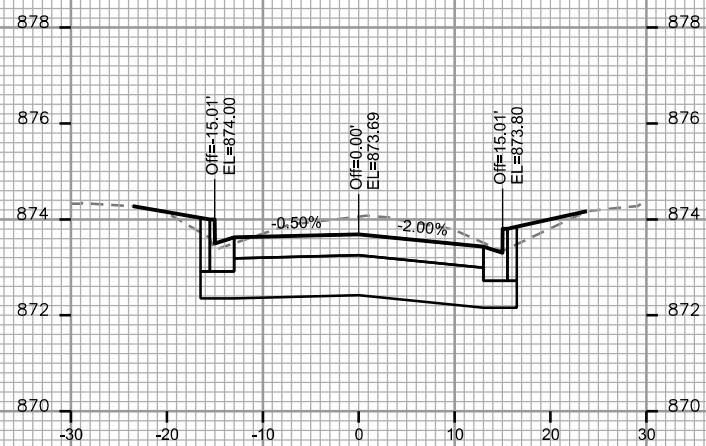
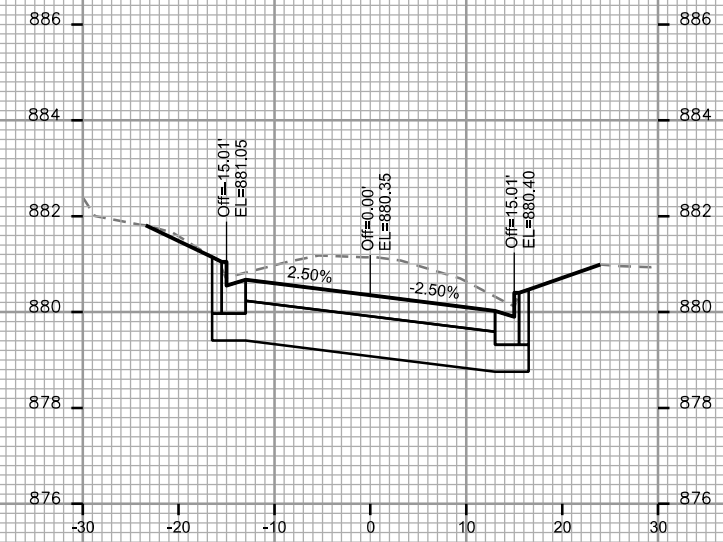
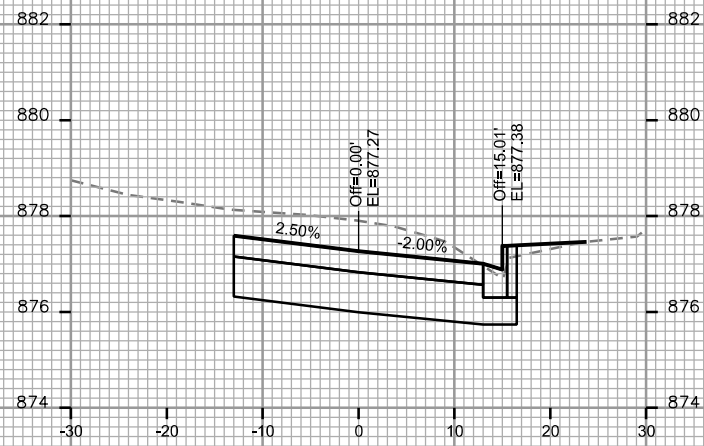
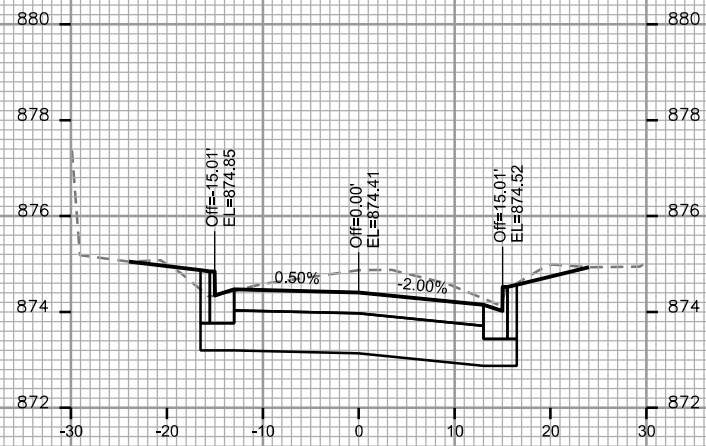
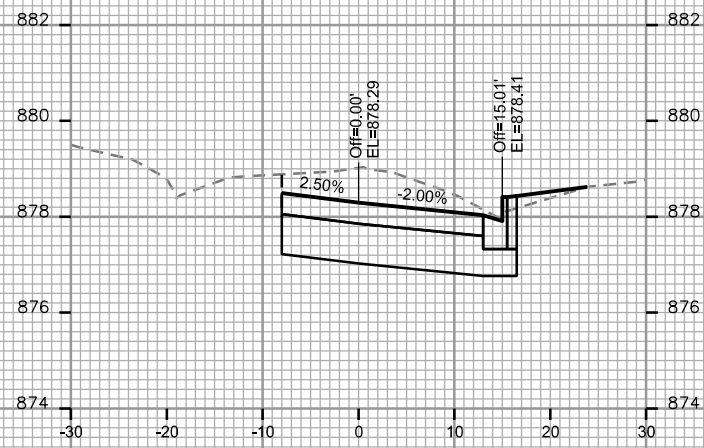
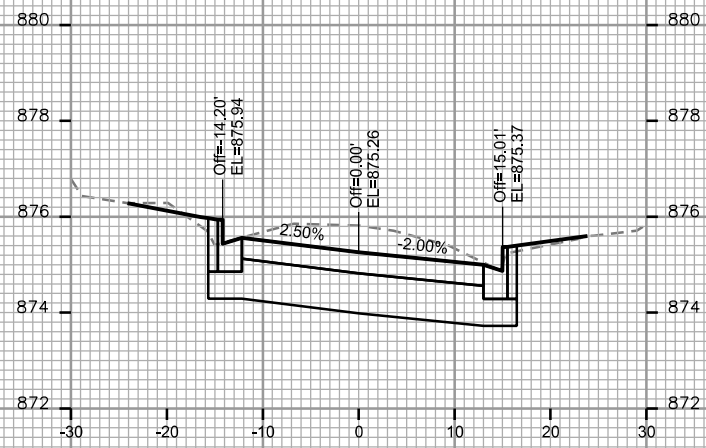

PLOT SCALE: _____

PLOT NAME: _____

REV. DATE: _____

ORIGINATOR: CITY OF MADISON - STREETS DIVISION

CROSS SECTIONS
COMMONWEALTH AVENUE CITY OF MADISON

PLOT SCALE: _____
PLOT NAME: _____

REV. DATE: _____

ORIGINATOR: CITY OF MADISON - STREETS DIVISION

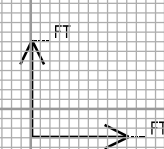
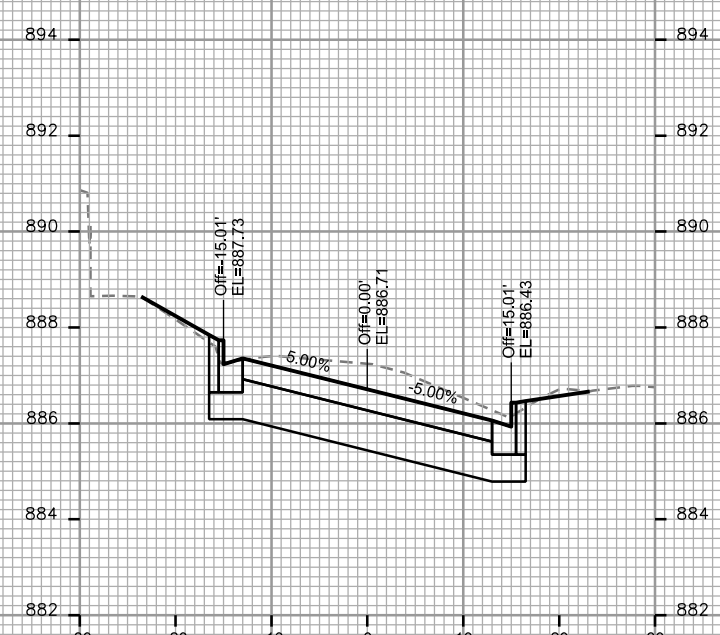
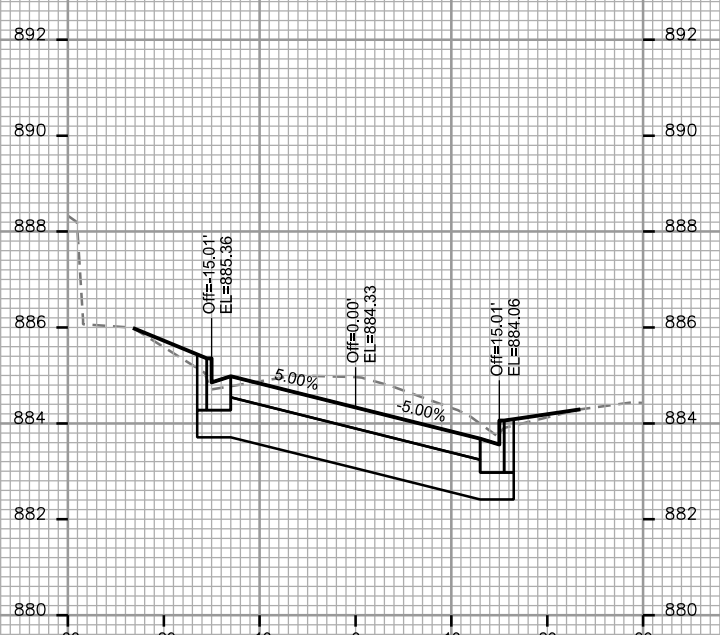
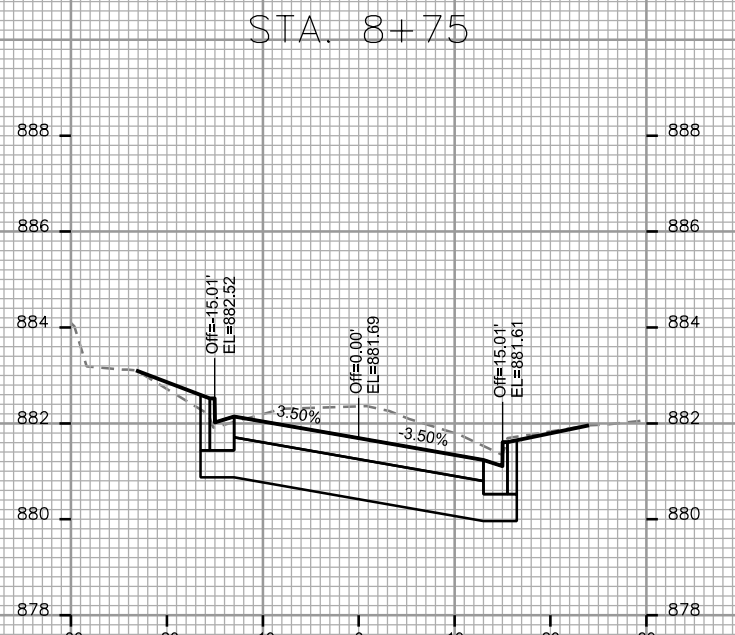
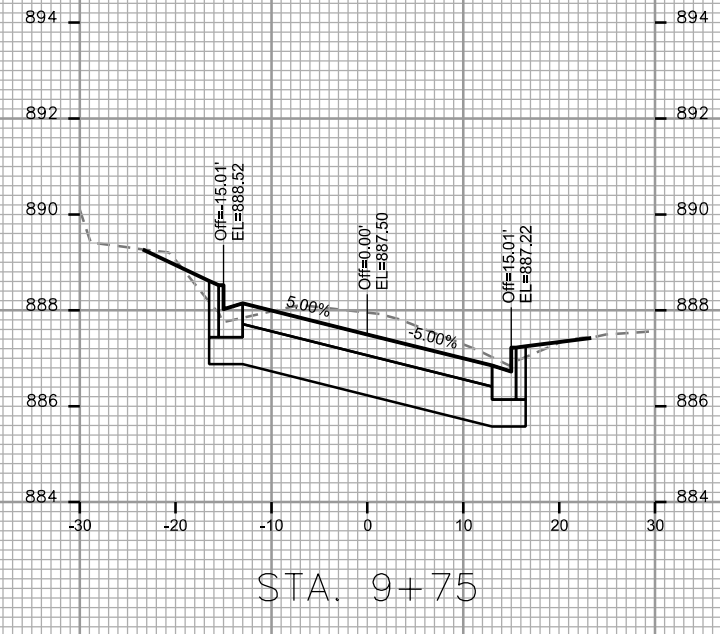
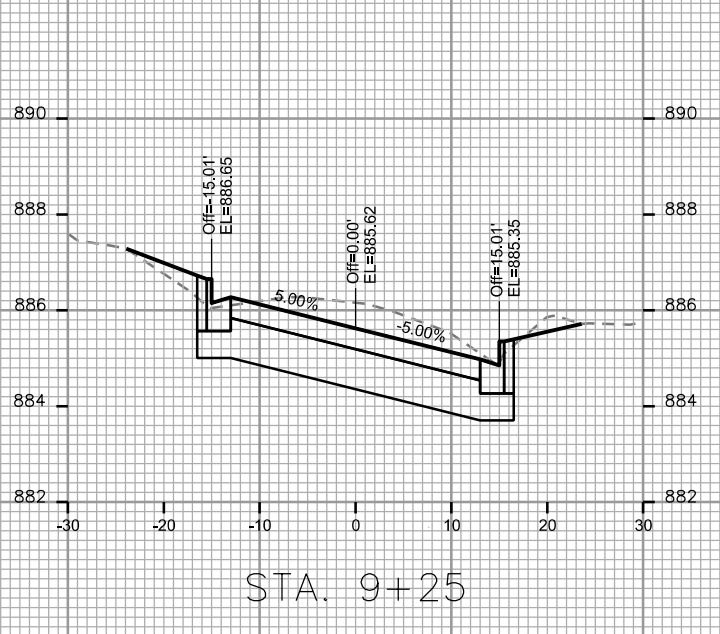
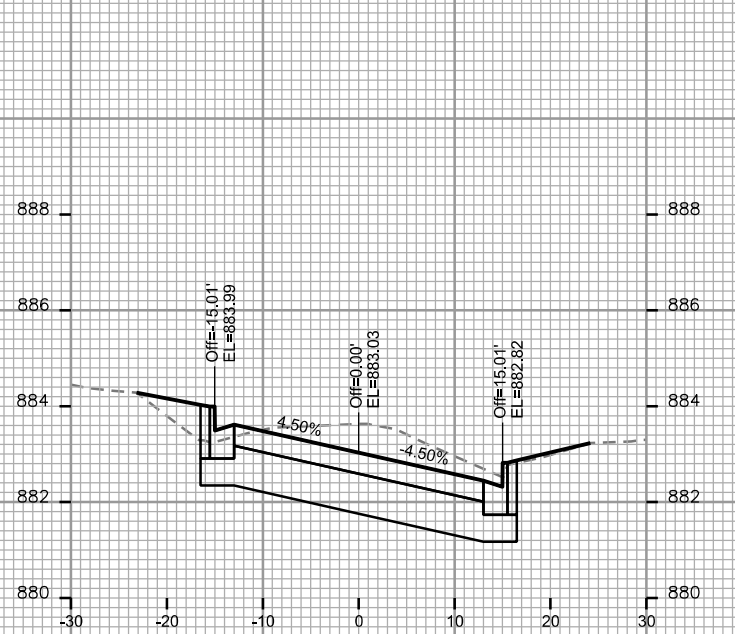

CROSS SECTIONS

COMMONWEALTH AVENUE CITY OF MADISON

PLOT SCALE: _____

PLOT NAME: _____

REV. DATE: _____

ORIGINATOR: CITY OF MADISON, STREETS DIVISION

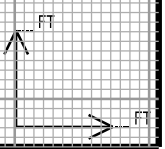
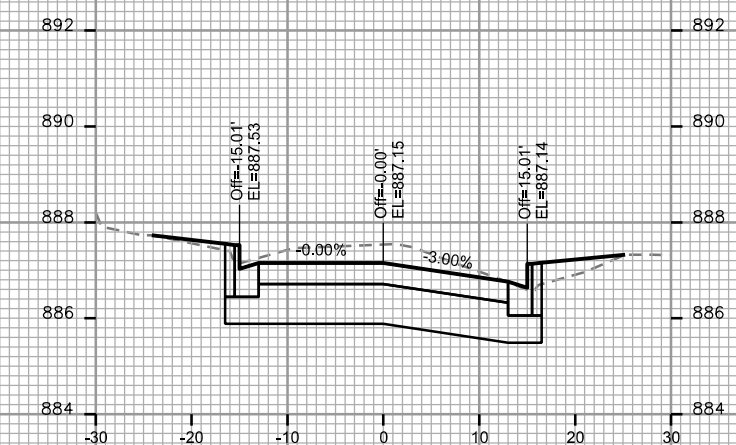
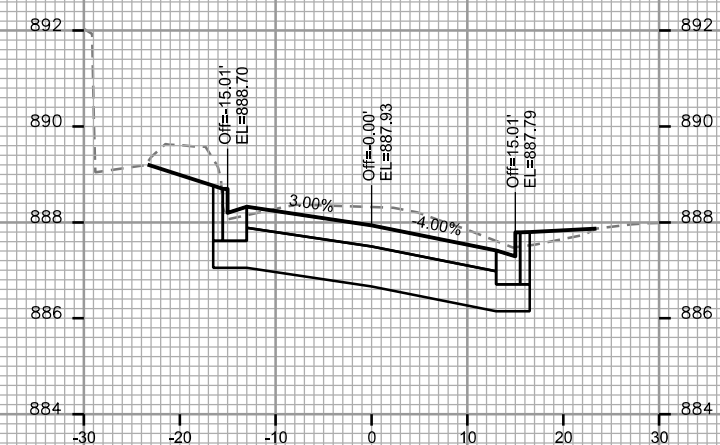
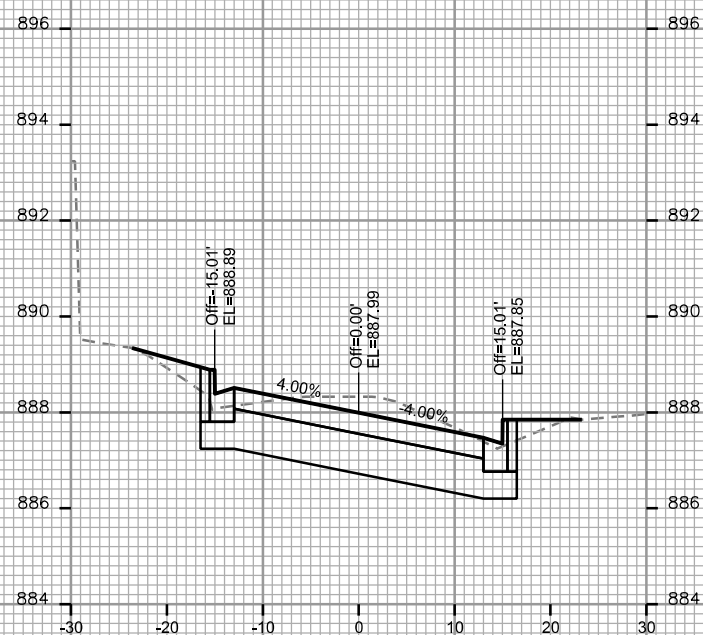
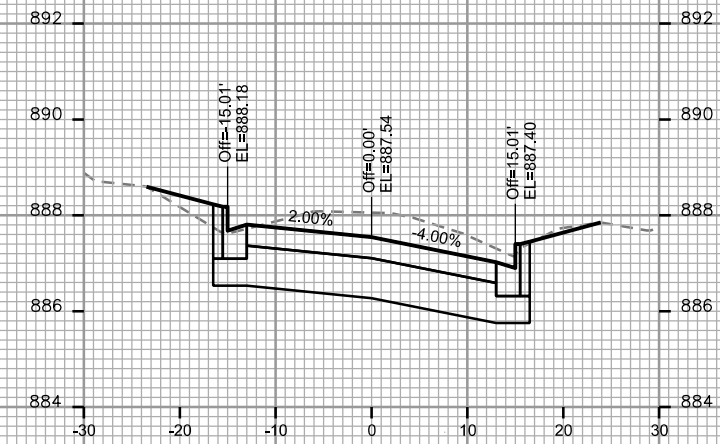
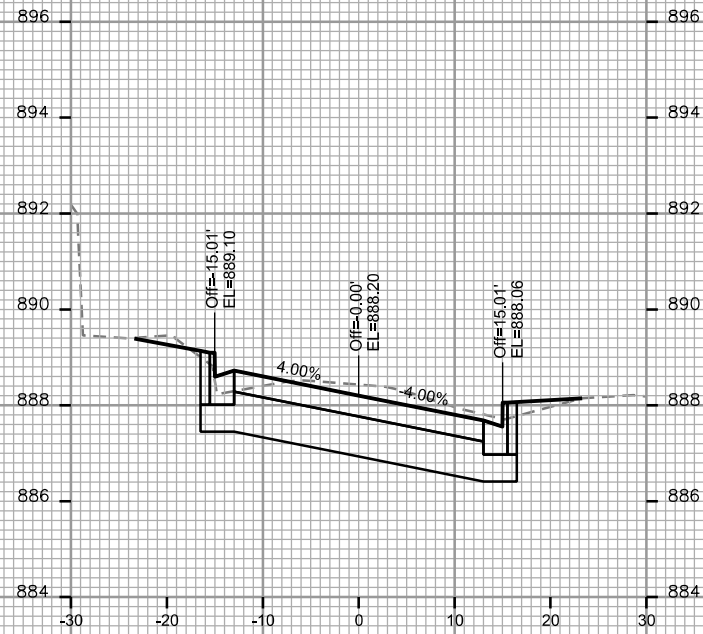

CROSS SECTIONS

COMMONWEALTH AVENUE CITY OF MADISON

PLOT SCALE: _____

PLOT NAME: _____

REV. DATE: _____

ORIGINATOR: CITY OF MADISON, STREETS DIVISION

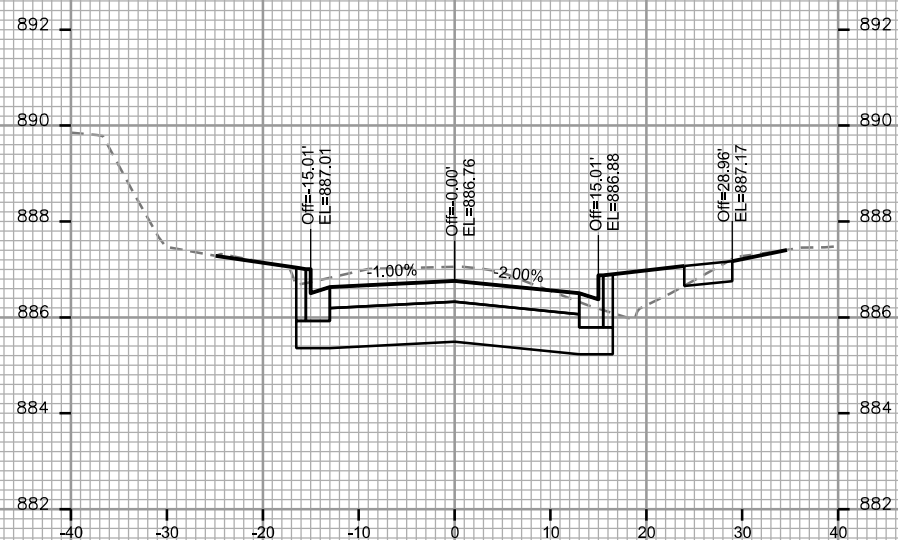
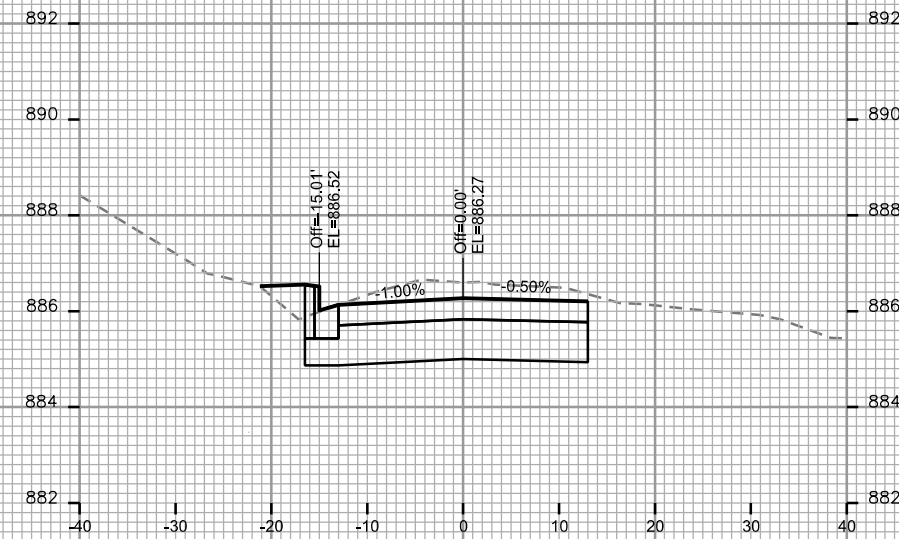
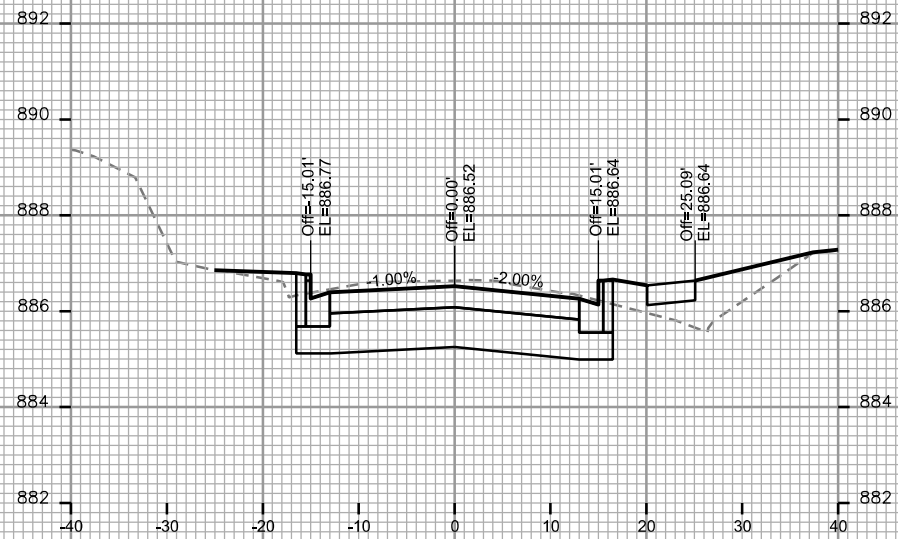

CROSS SECTIONS
COMMONWEALTH AVENUE CITY OF MADISON

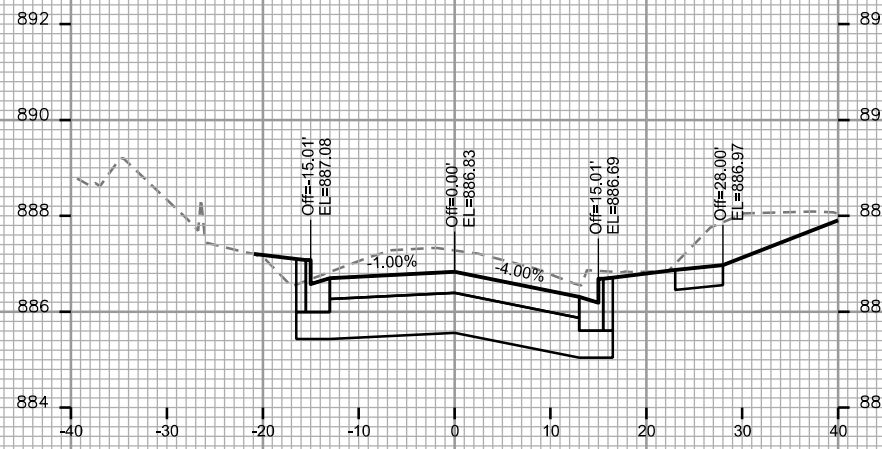

STA. 12+75

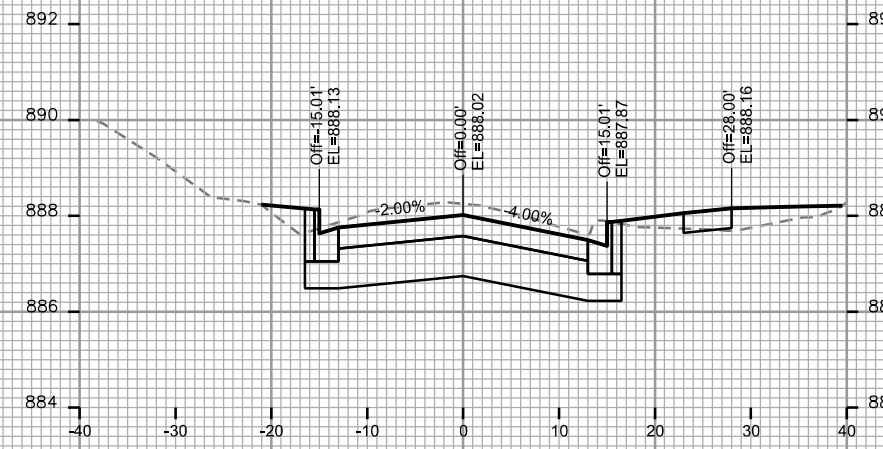

STA. 13+50

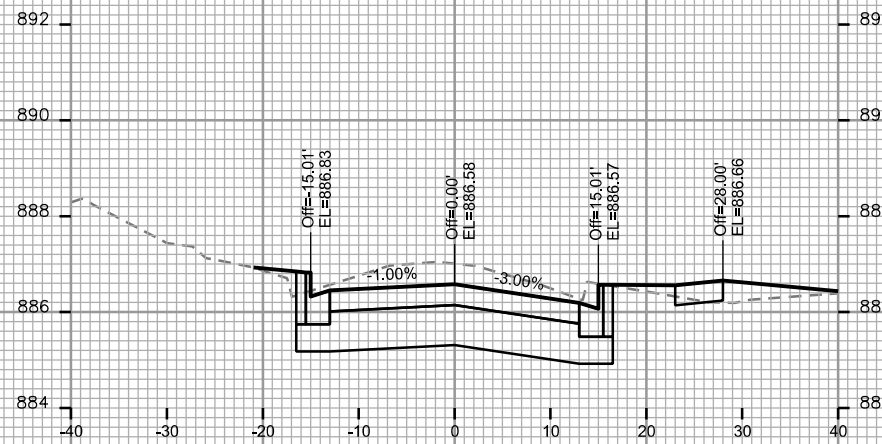

STA. 12+50

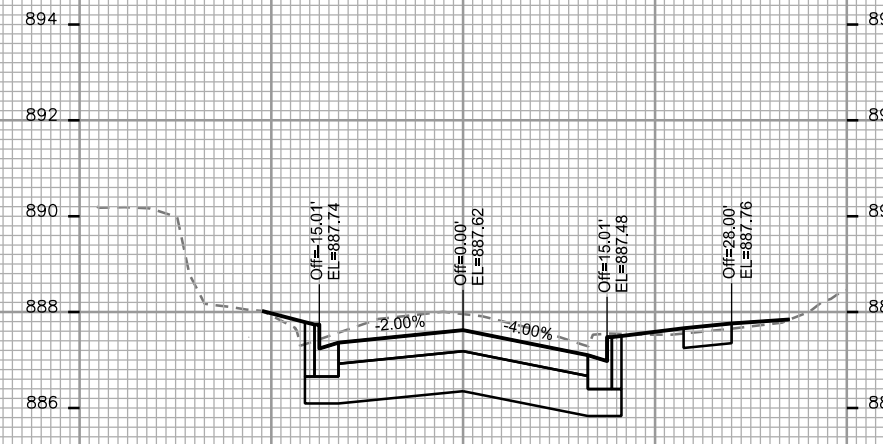

STA. 13+25

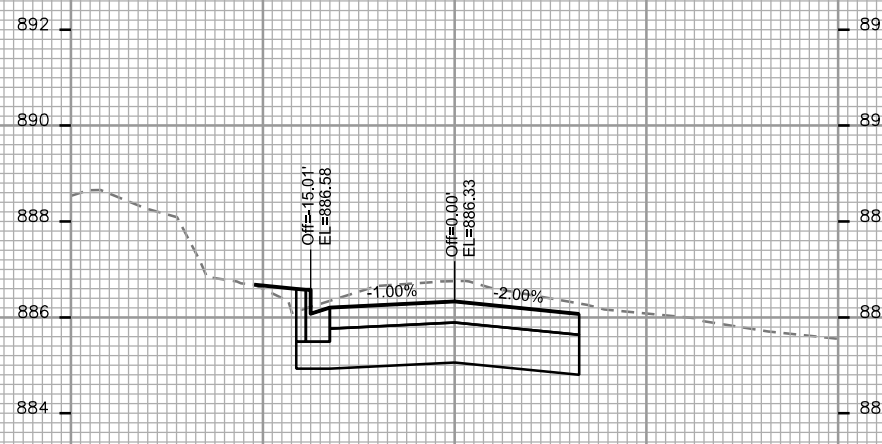

STA. 12+25

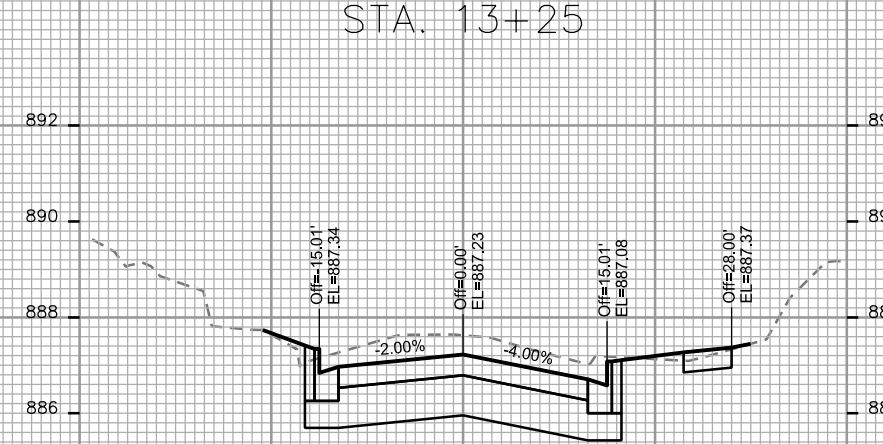

STA. 13+00

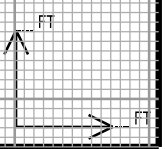

PLOT SCALE: _____

PLOT NAME: _____

REV. DATE: _____

ORIGINATOR: CITY OF MADISON, STREETS DIVISION

CROSS SECTIONS

COMMONWEALTH AVENUE CITY OF MADISON

PLOT SCALE: _____

PLOT NAME: _____

REV. DATE: _____

ORIGINATOR: CITY OF MADISON, STREETS DIVISION

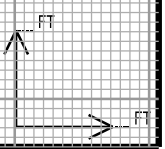
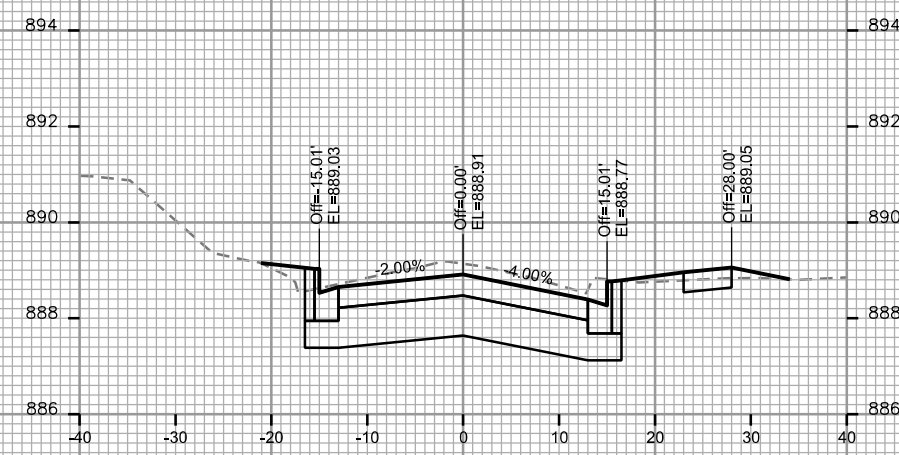
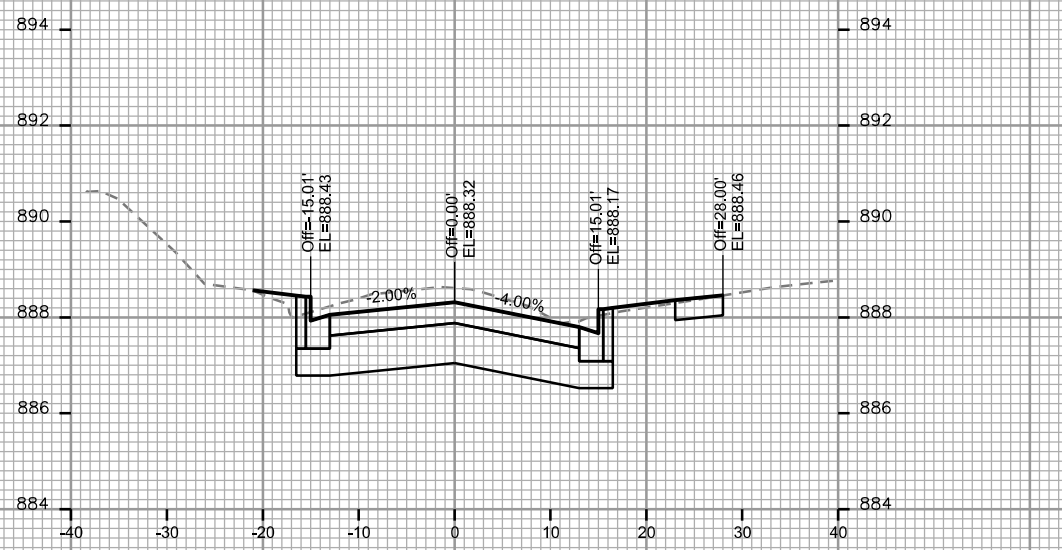
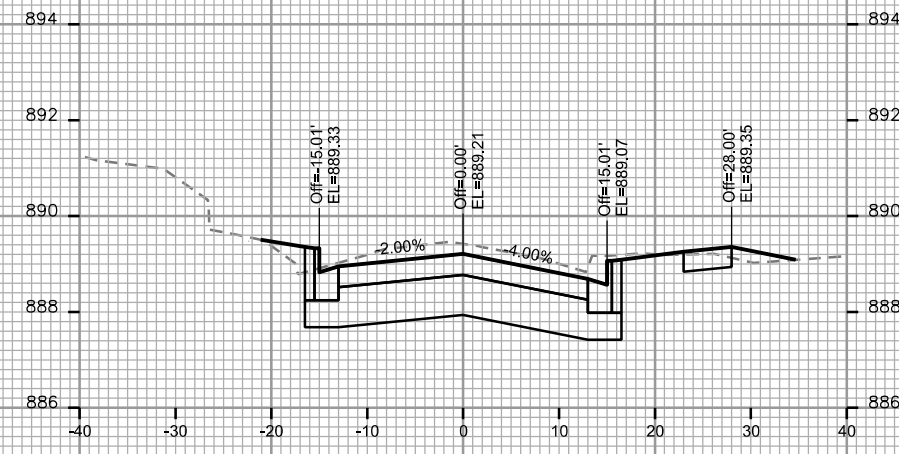
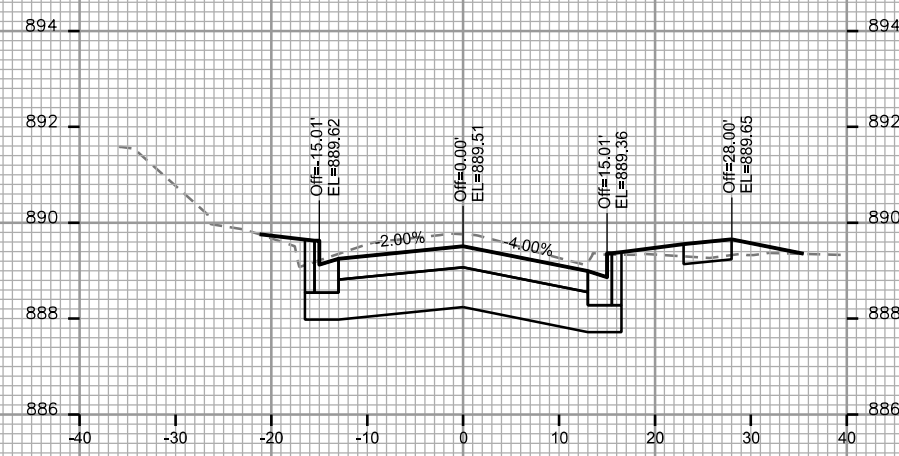
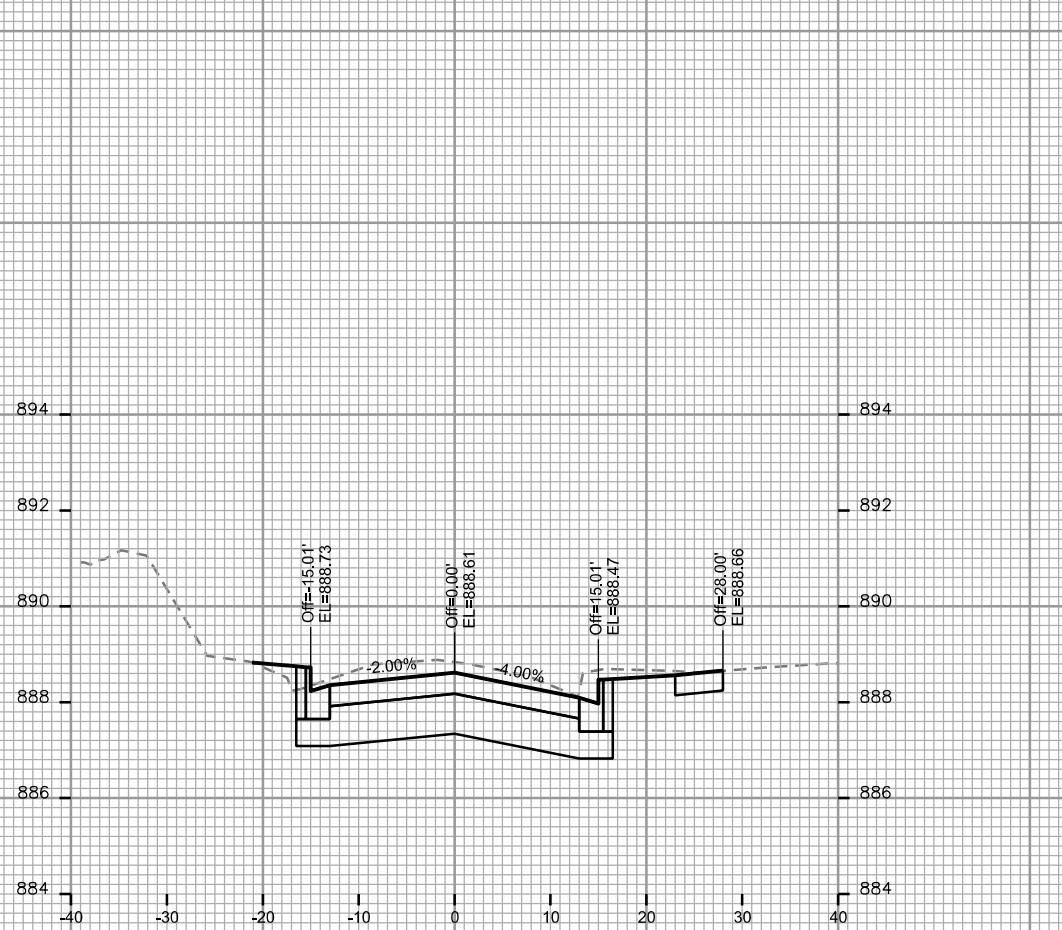

CROSS SECTIONS
COMMONWEALTH AVENUE CITY OF MADISON

PLOT SCALE: _____

PLOT NAME: _____

REV. DATE: _____

ORIGINATOR: CITY OF MADISON, STREETS DIVISION

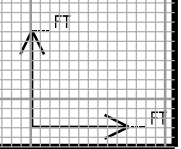
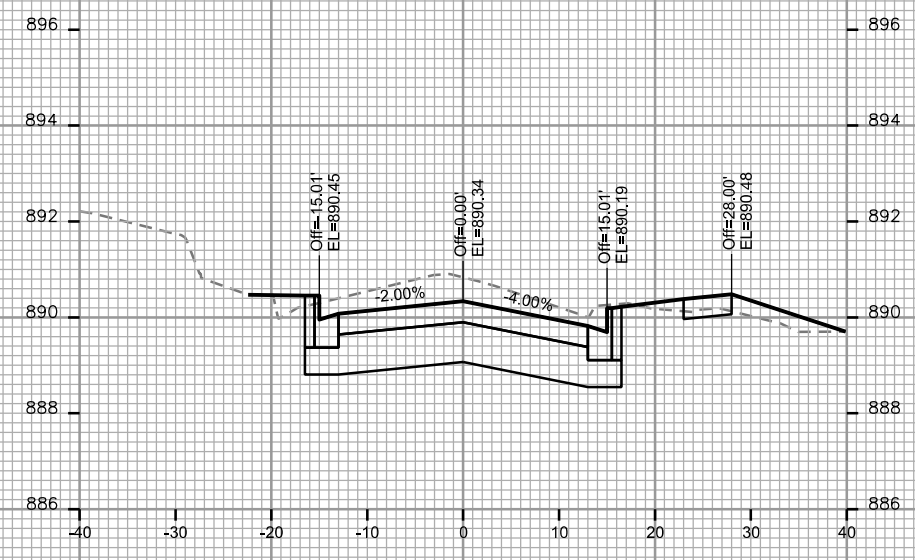
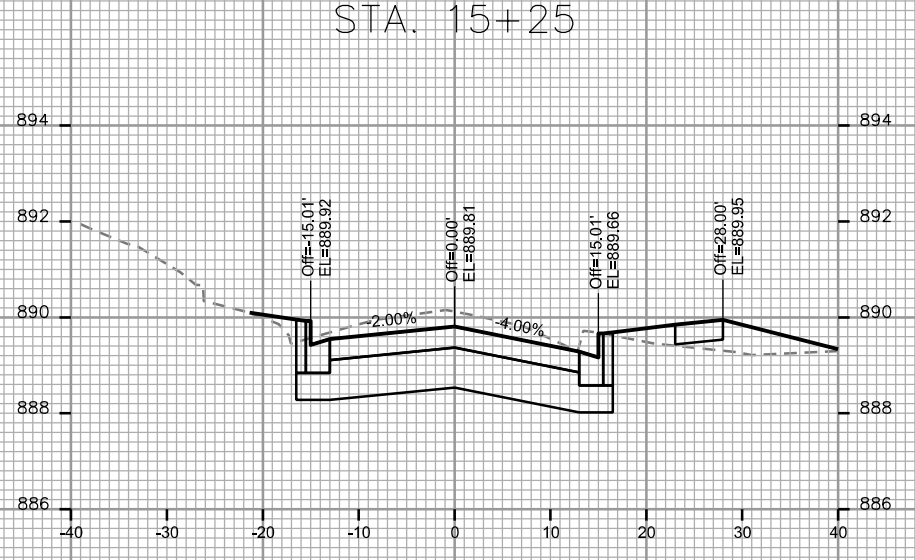
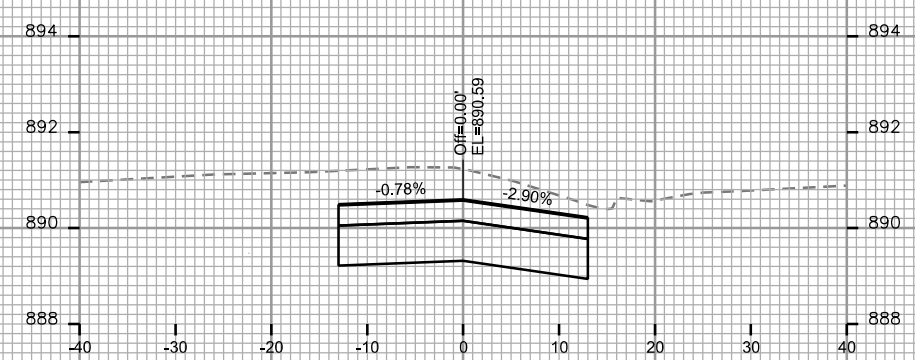
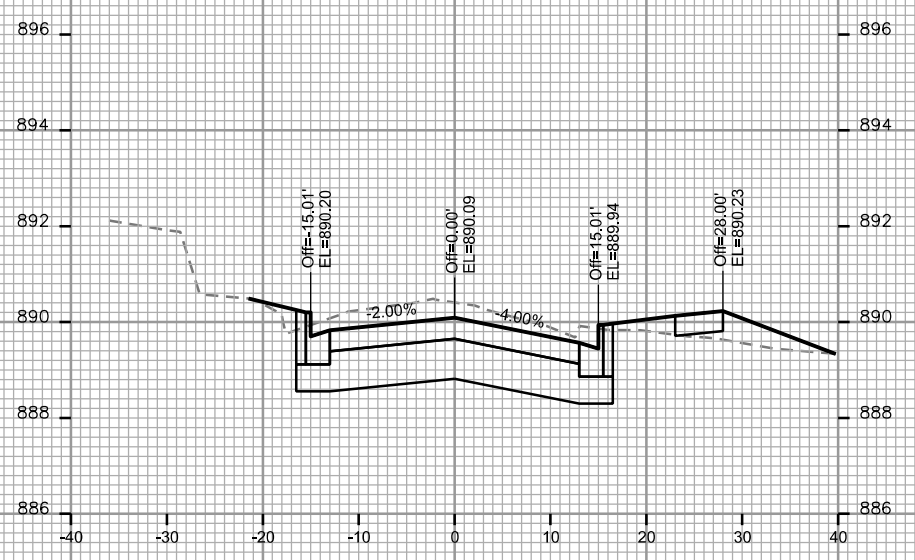
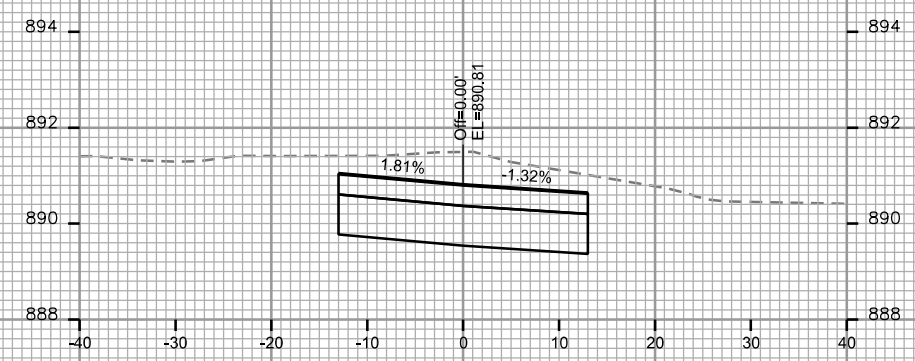

CROSS SECTIONS
COMMONWEALTH AVENUE CITY OF MADISON

PLOT SCALE: _____

PLOT NAME: _____

REV. DATE: _____

ORIGINATOR: CITY OF MADISON, STREETS DIVISION

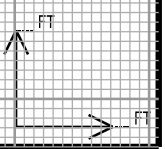
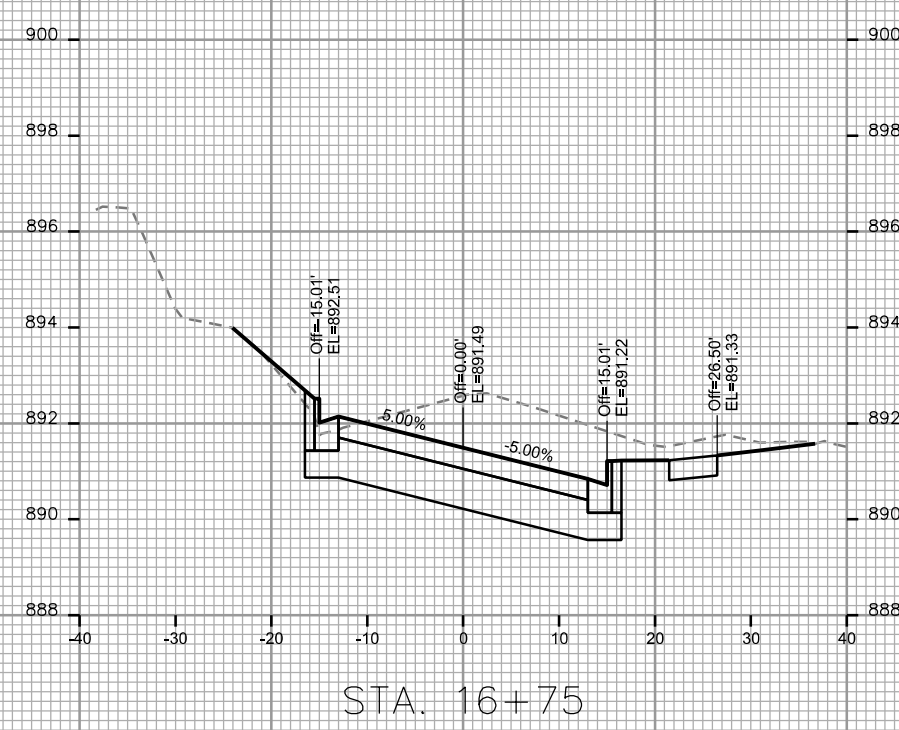
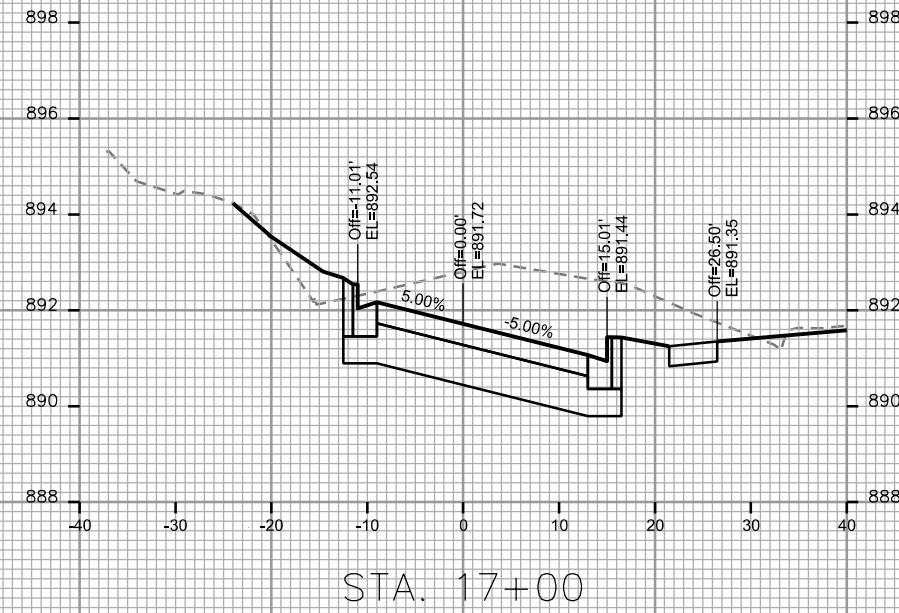
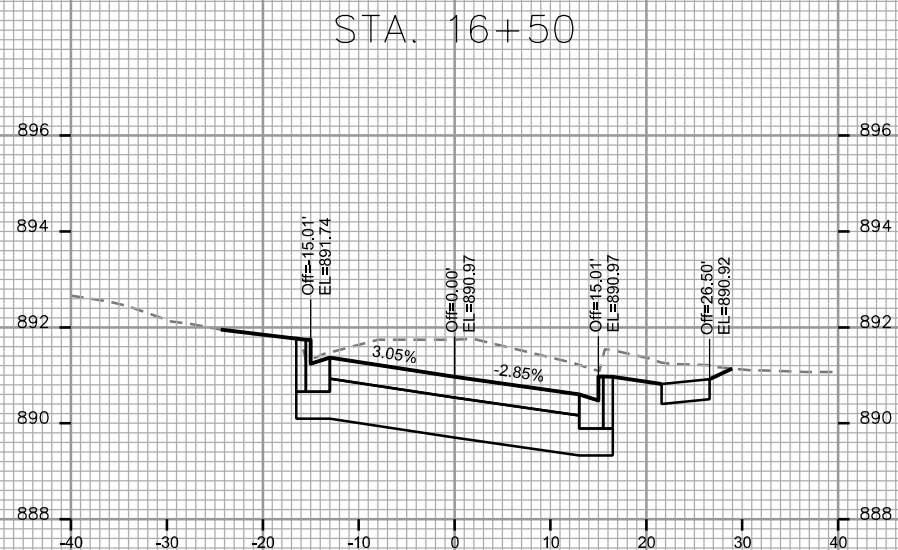
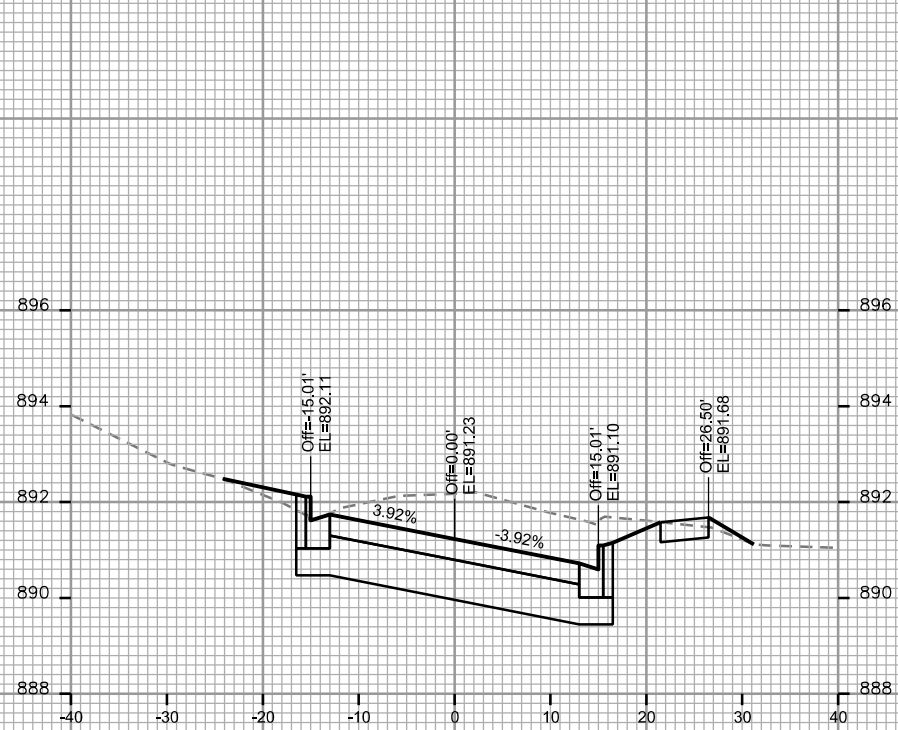

CROSS SECTIONS

COMMONWEALTH AVENUE CITY OF MADISON
REVISED LRC 5/8/14

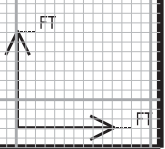
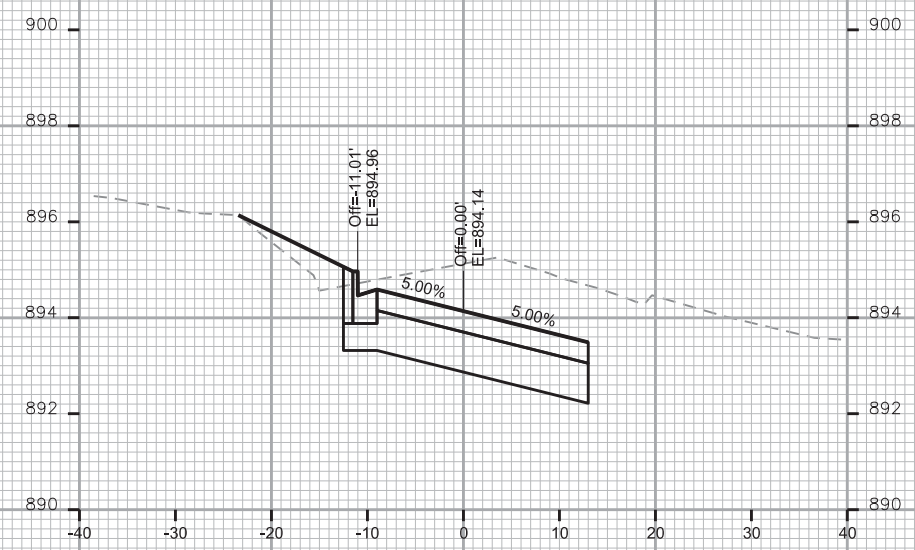
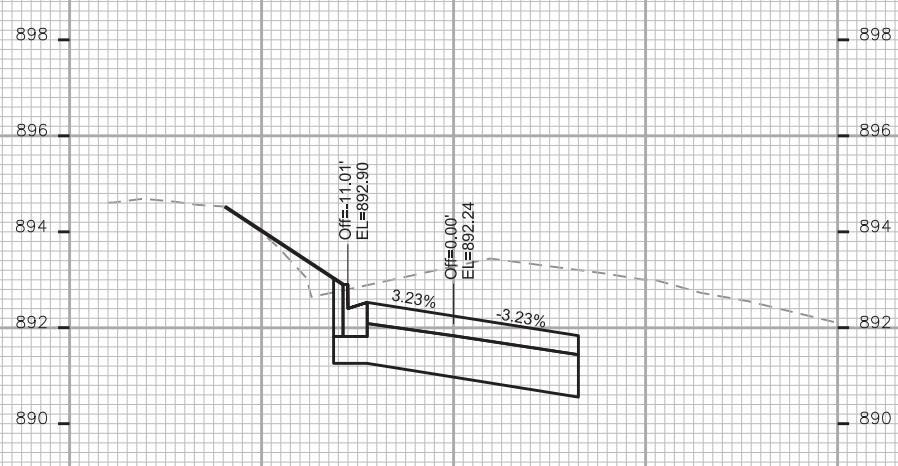
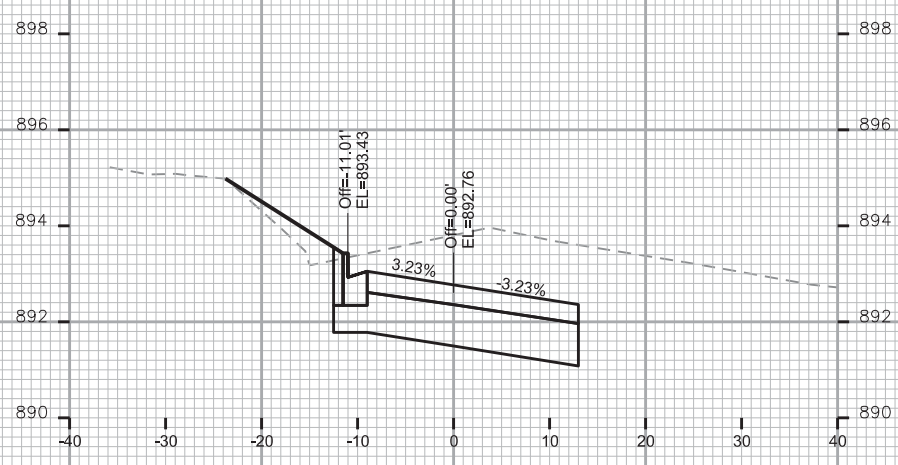
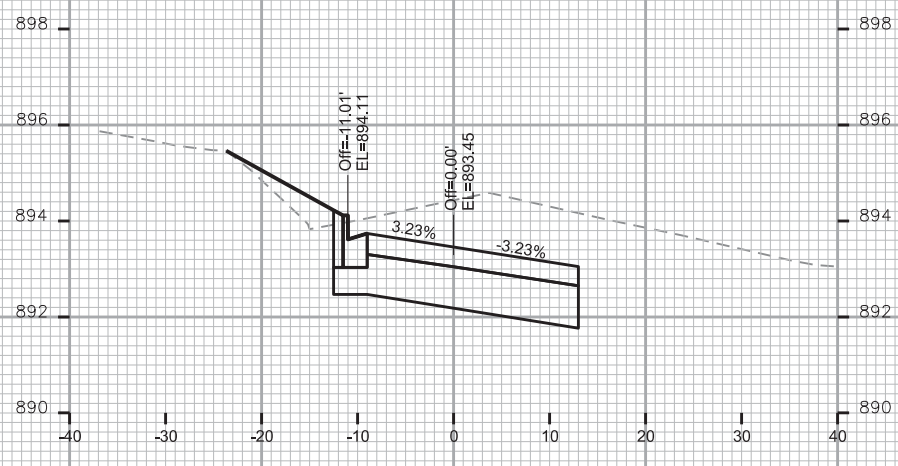

PLOT SCALE: _____

PLOT NAME: _____

REV. DATE: _____

ORIGINATOR: CITY OF MADISON, STREETS DIVISION

CROSS SECTIONS
COMMONWEALTH AVENUE CITY OF MADISON

PLOT SCALE: _____

PLOT NAME: _____

REV. DATE: _____

ORIGINATOR: CITY OF MADISON, STREETS DIVISION

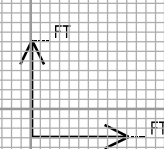
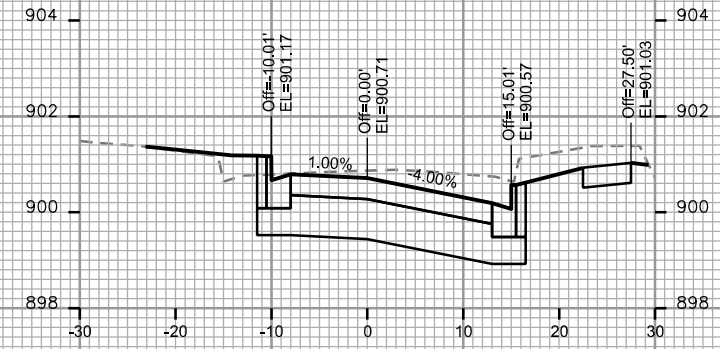
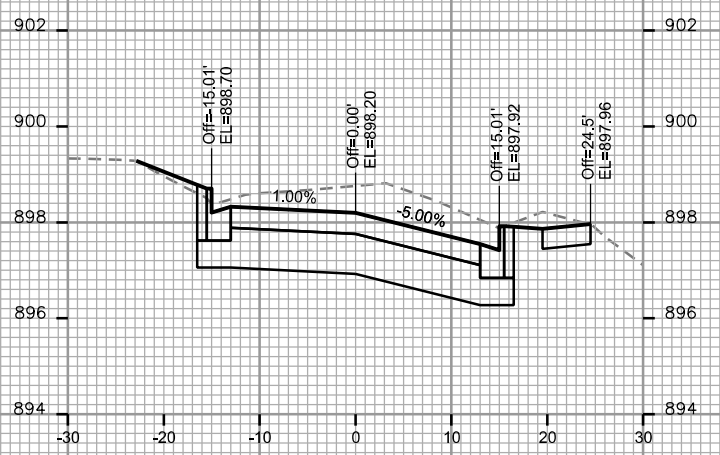
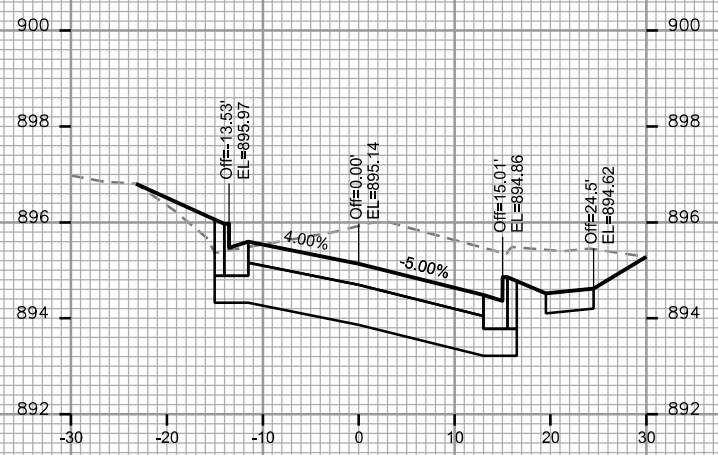
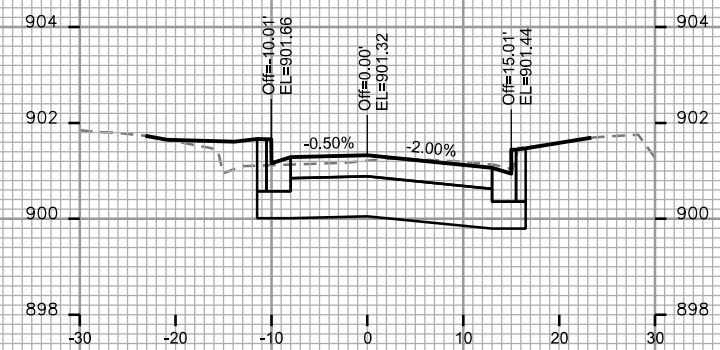
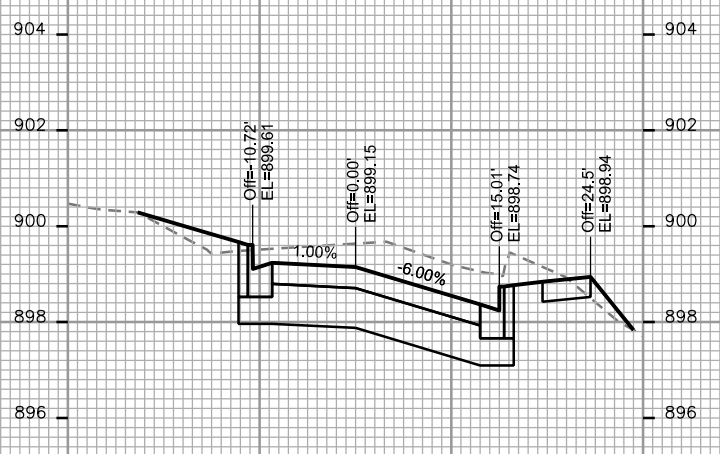
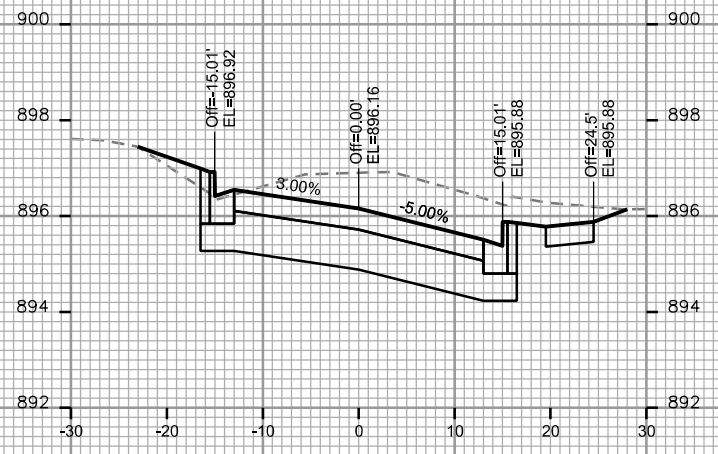
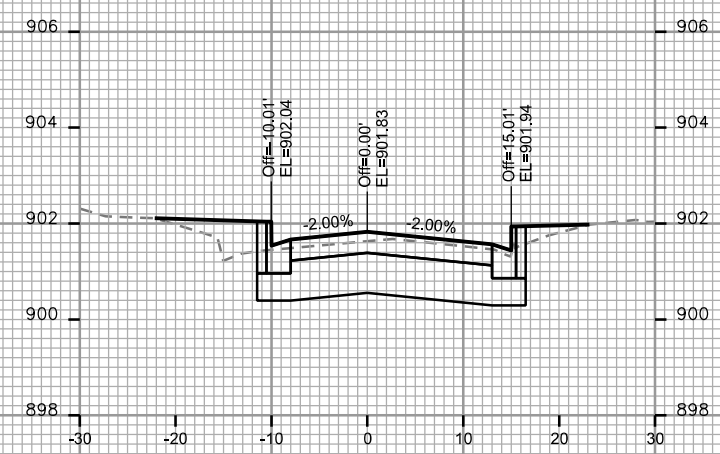
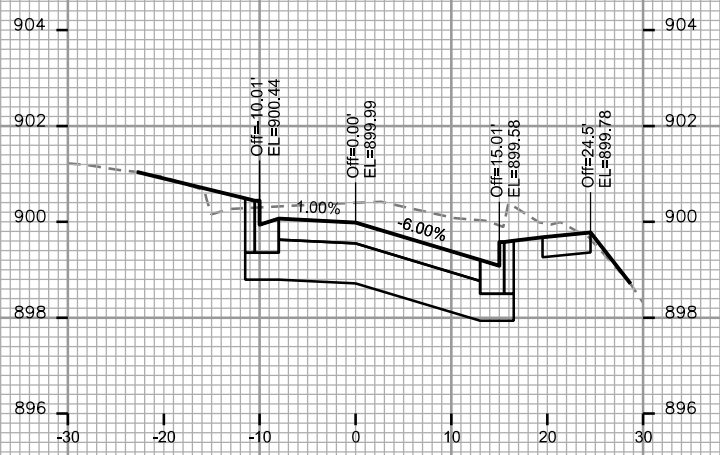
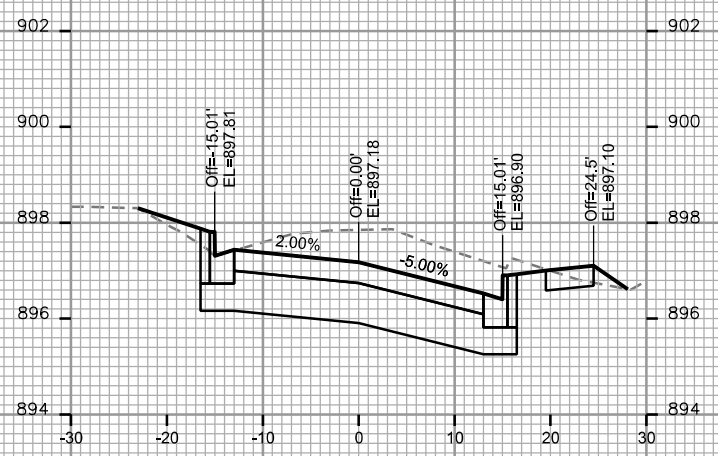

CROSS SECTIONS
COMMONWEALTH AVENUE CITY OF MADISON

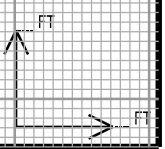
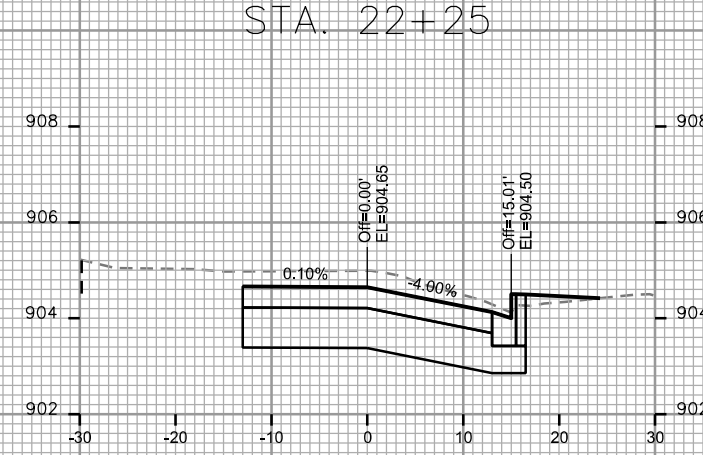
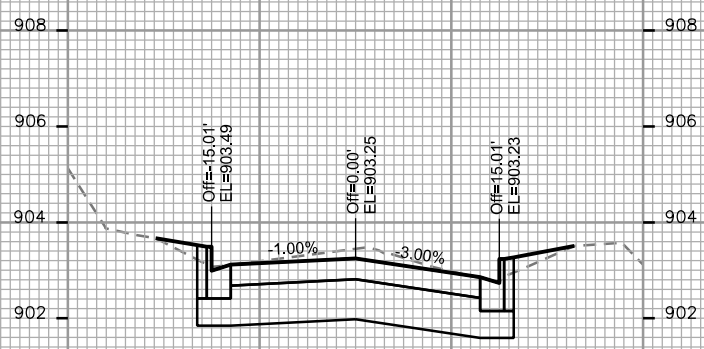
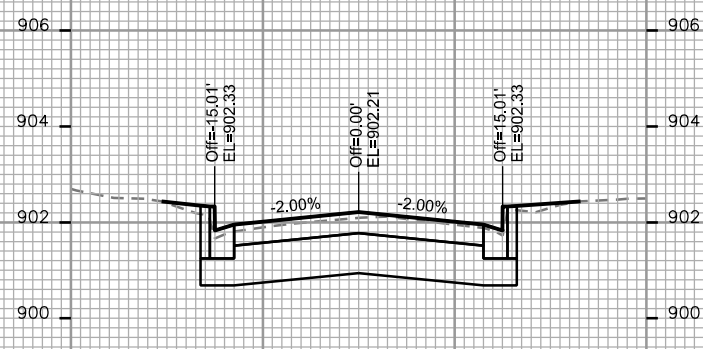
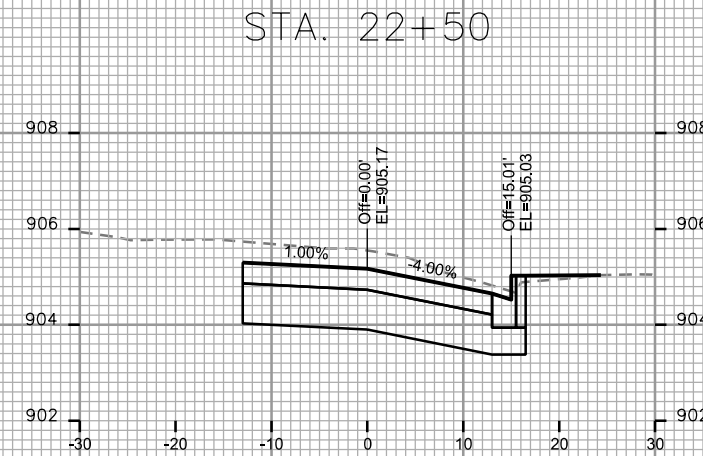
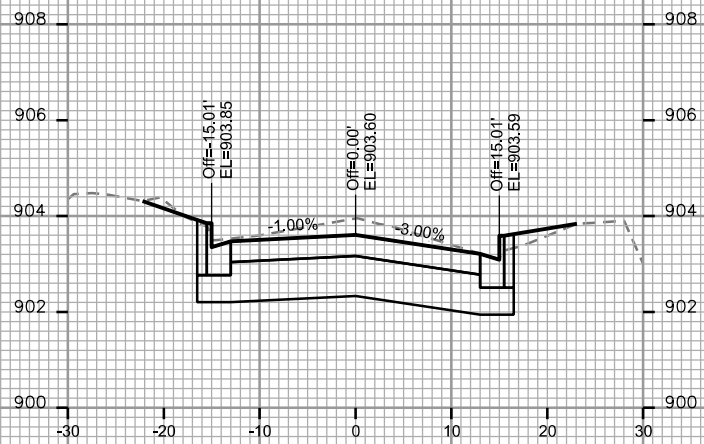
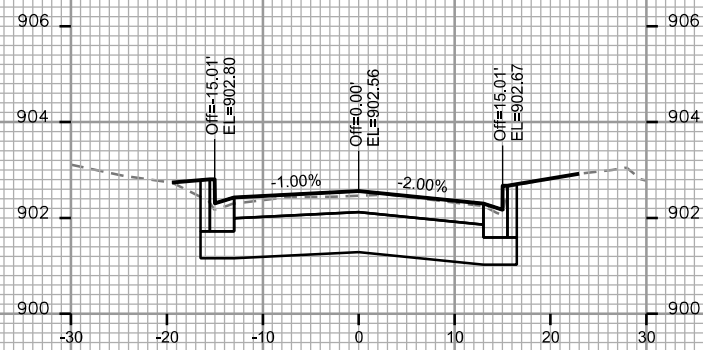
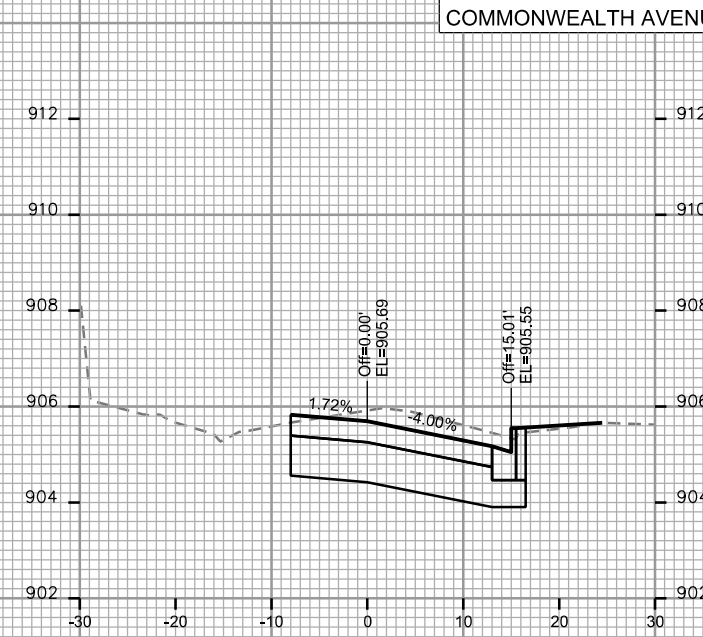
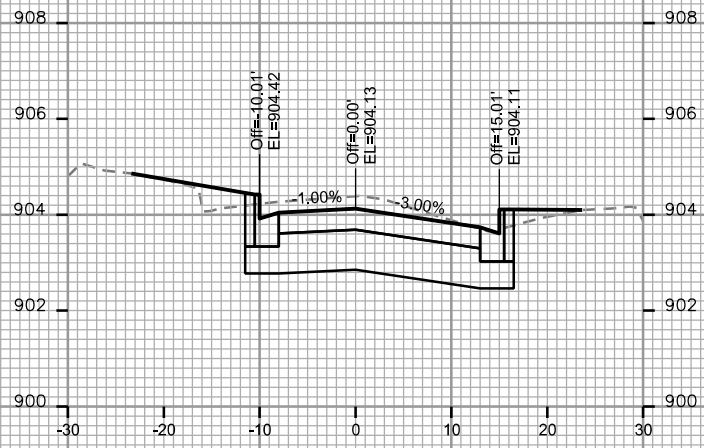
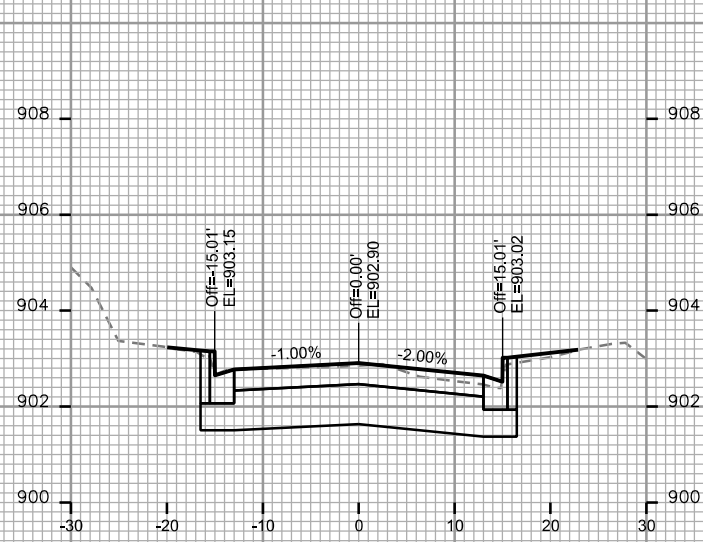

PLOT SCALE: _____

PLOT NAME: _____

REV. DATE: _____

ORIGINATOR: CITY OF MADISON - STREETS DIVISION

CROSS SECTIONS
COMMONWEALTH AVENUE CITY OF MADISON

PLOT SCALE: _____

PLOT NAME: _____

REV. DATE: _____

ORIGINATOR: CITY OF MADISON - STREETS DIVISION

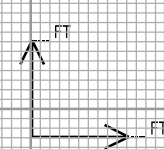
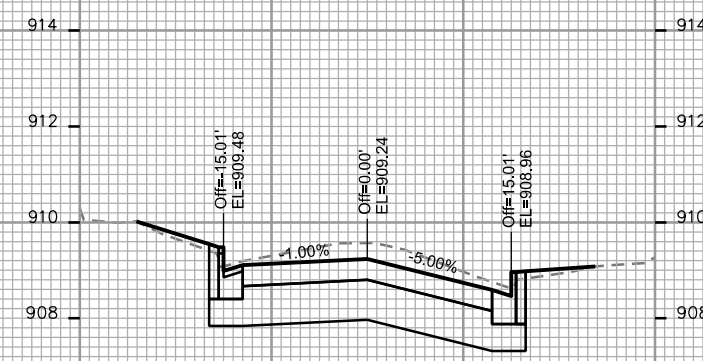
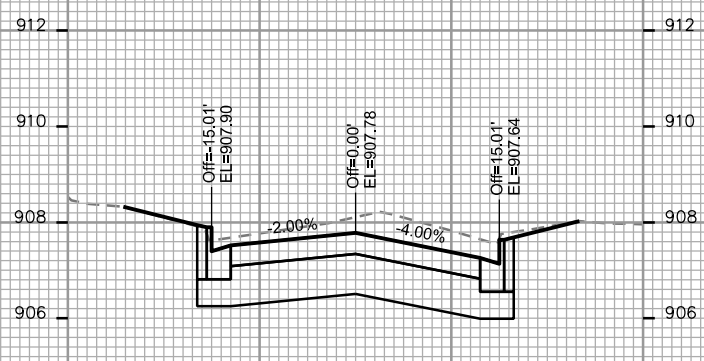
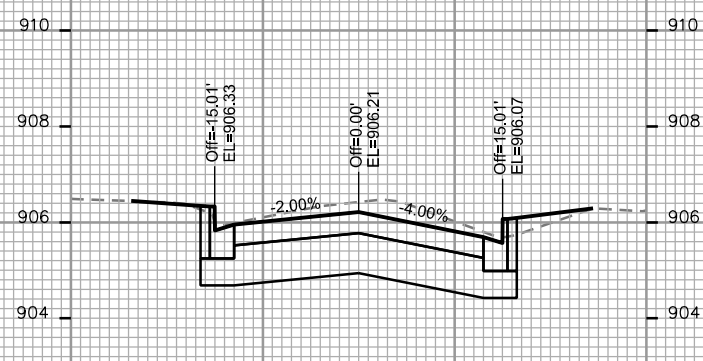
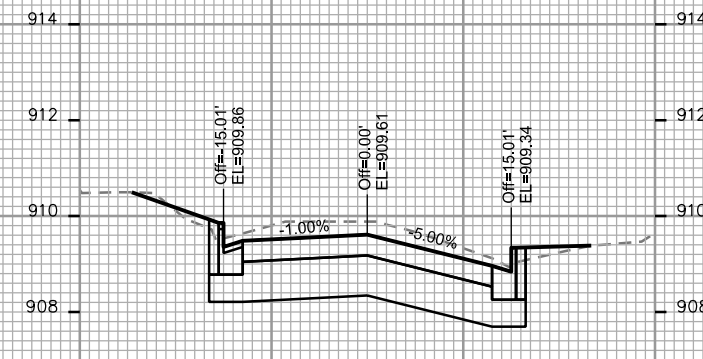
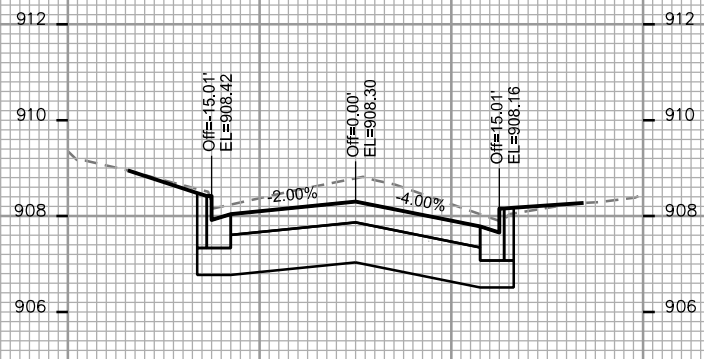
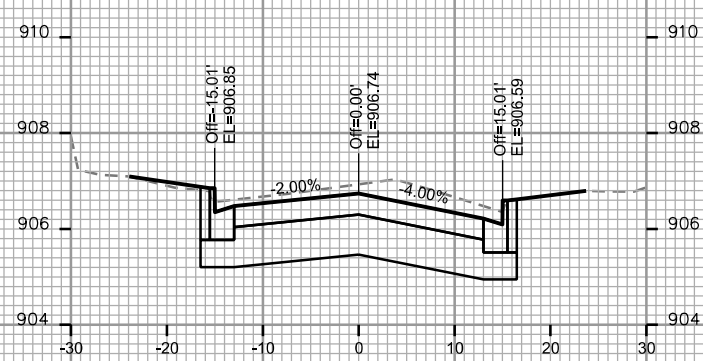
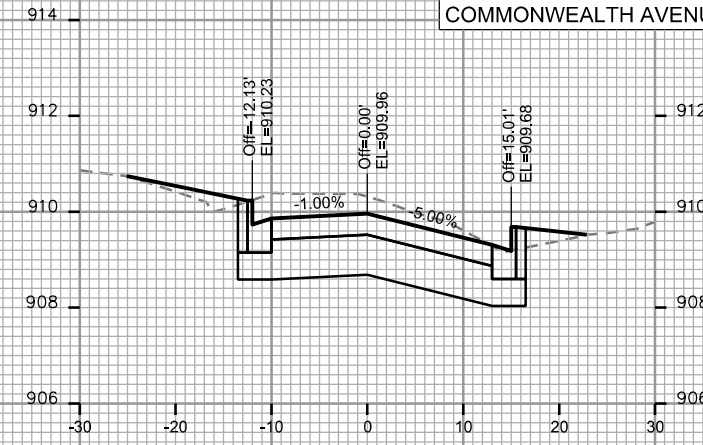
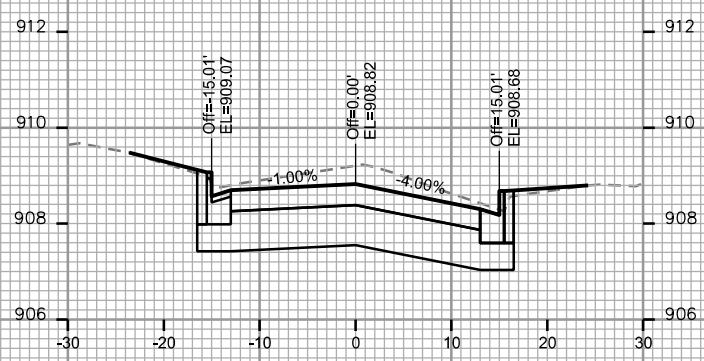
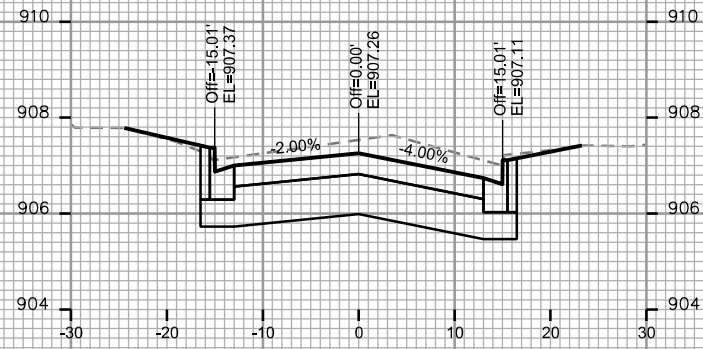

CROSS SECTIONS
COMMONWEALTH AVENUE CITY OF MADISON

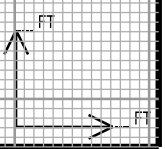
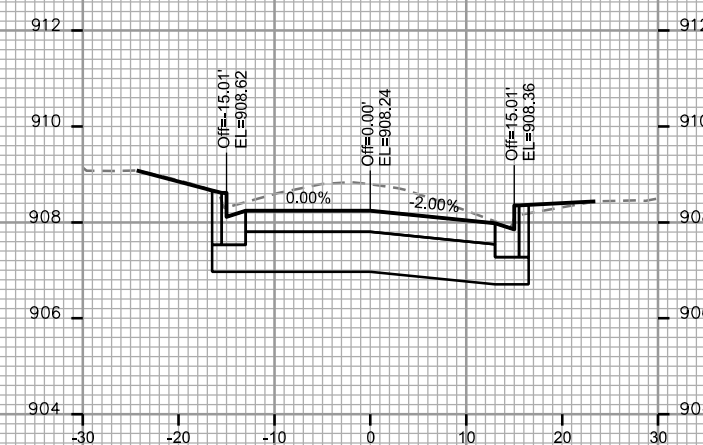
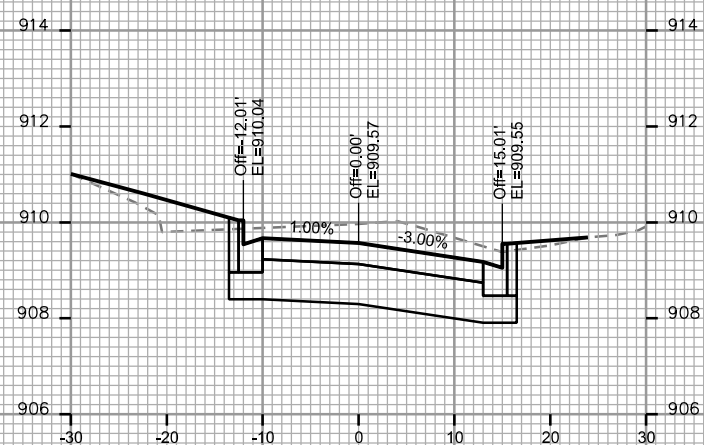
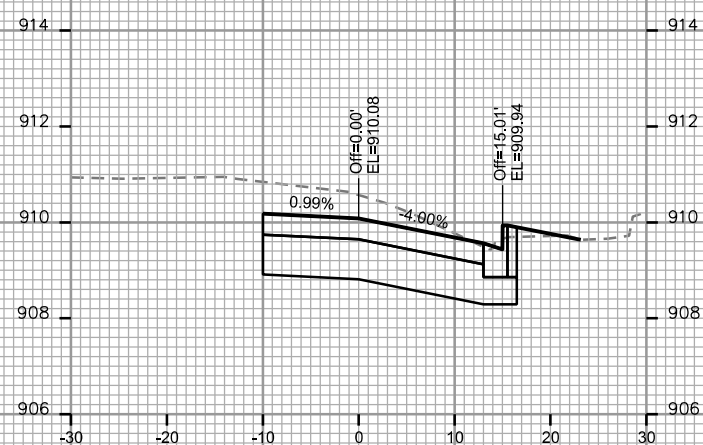
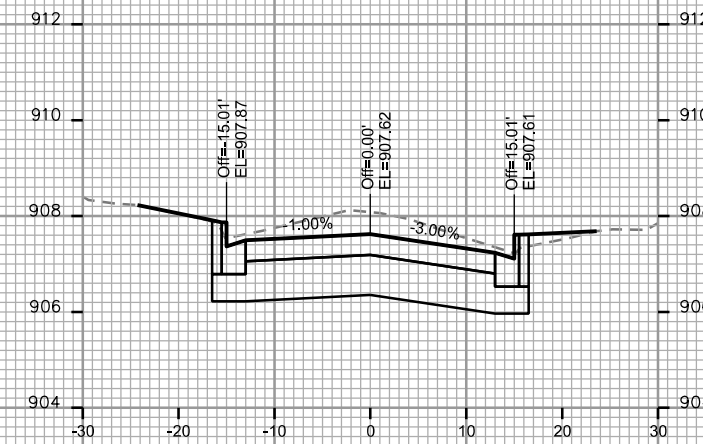
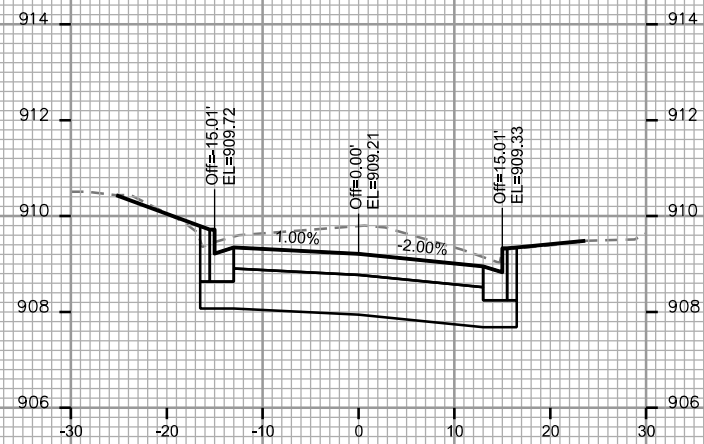
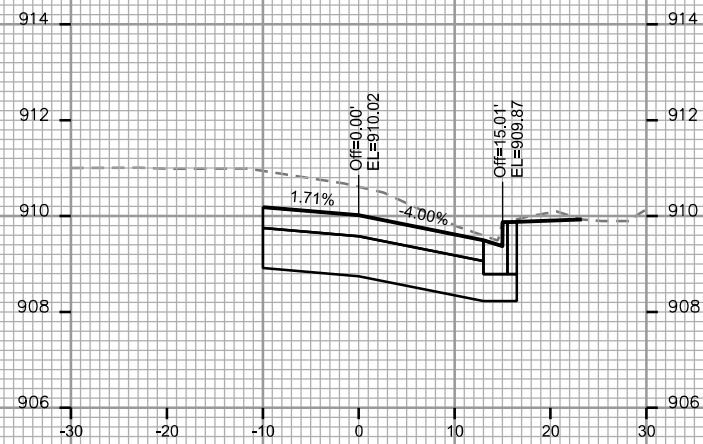
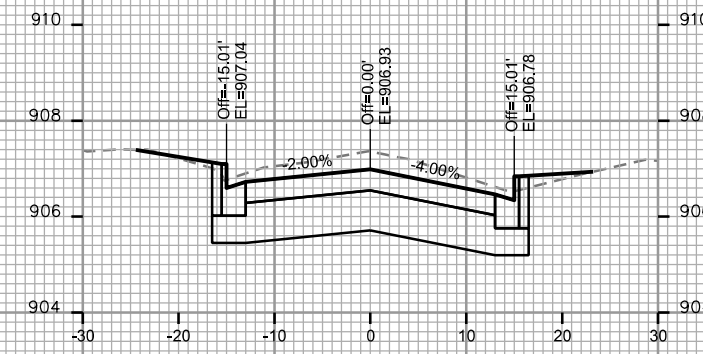
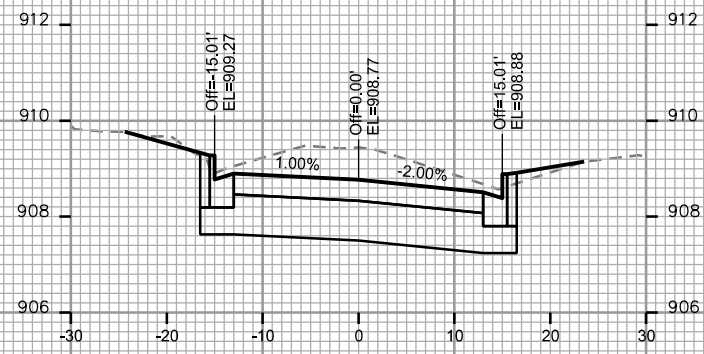
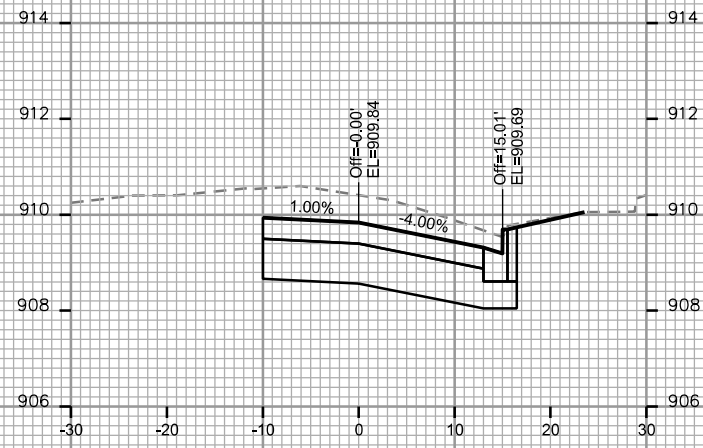

PLOT SCALE: _____

PLOT NAME: _____

REV. DATE: _____

ORIGINATOR: CITY OF MADISON - STREETS DIVISION

CROSS SECTIONS
COMMONWEALTH AVENUE CITY OF MADISON

PLOT SCALE: _____

PLOT NAME: _____

REV. DATE: _____

ORIGINATOR: CITY OF MADISON - STREETS DIVISION

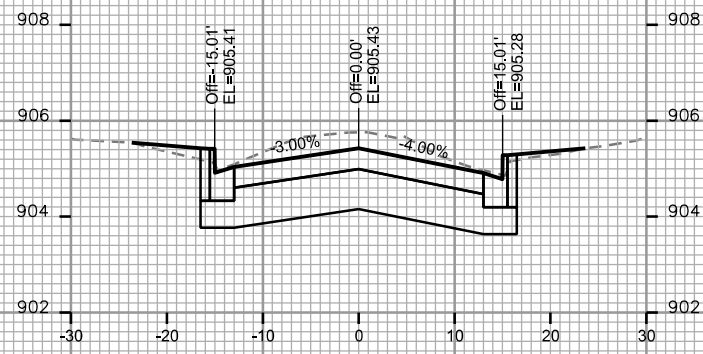

STA. 27+75

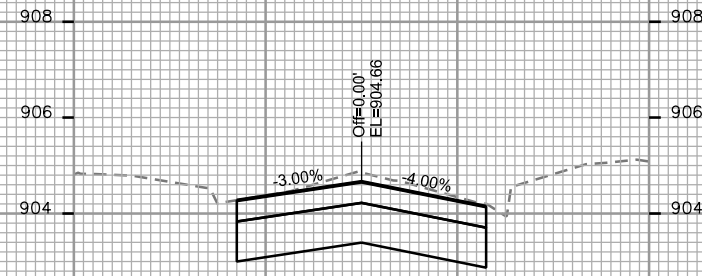

STA. 28+50

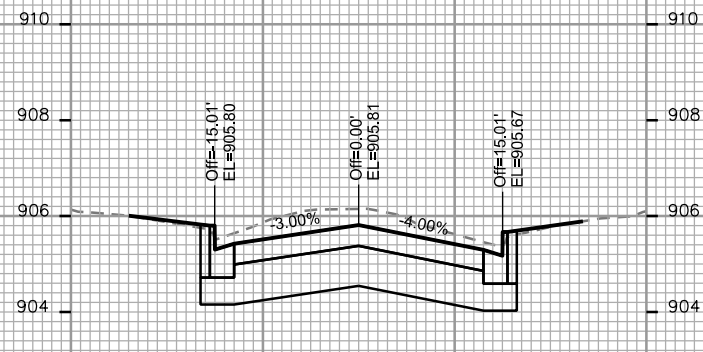

STA. 27+50

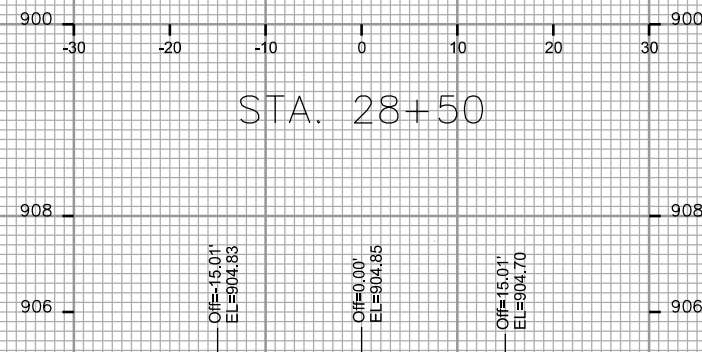

STA. 28+25

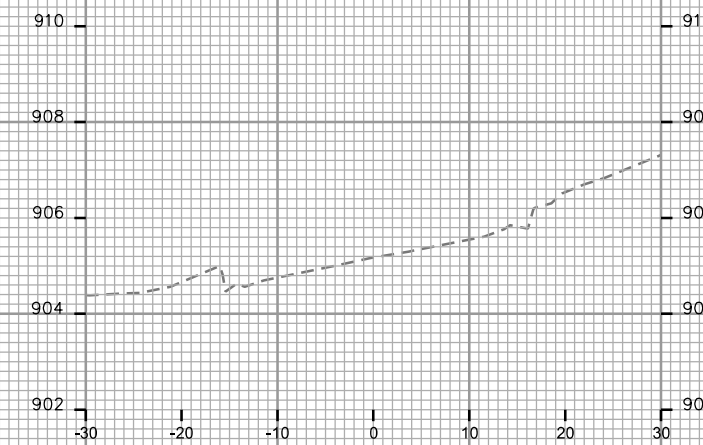

STA. 29+00

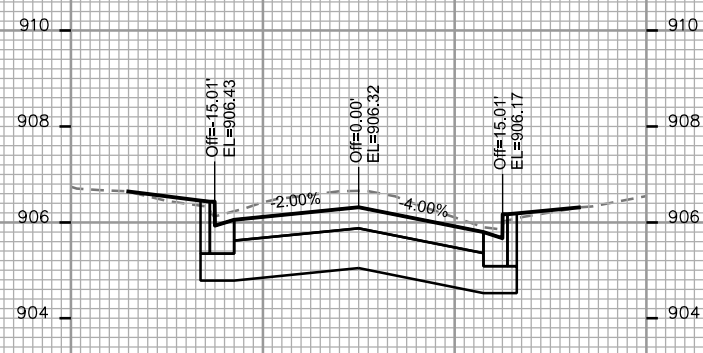

STA. 27+25

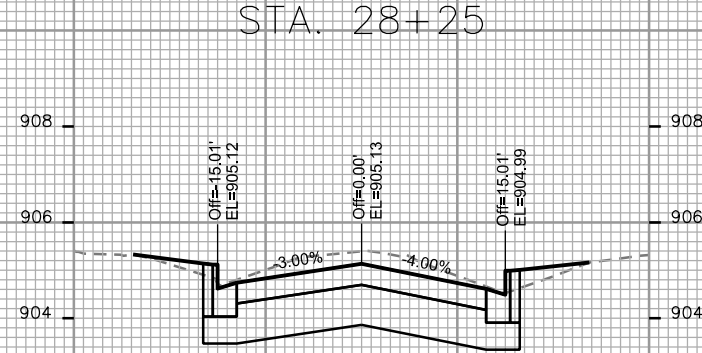

STA. 28+00

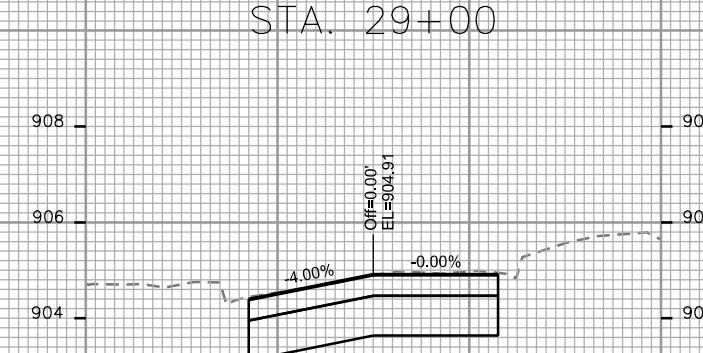

STA. 28+75

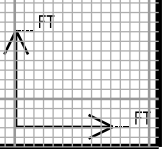

CROSS SECTIONS

FOX AVENUE
CITY OF MADISON
REVISED LRC 5/8/14

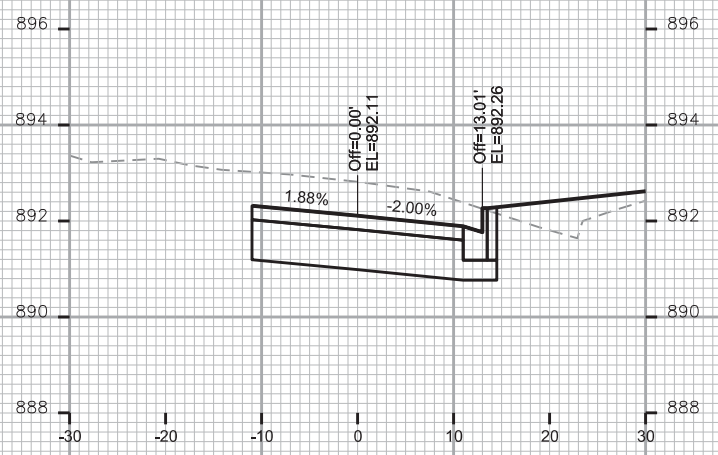

STA. 41+00

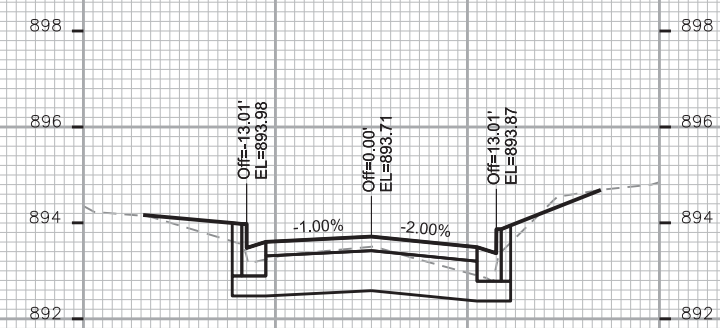

STA. 41+75

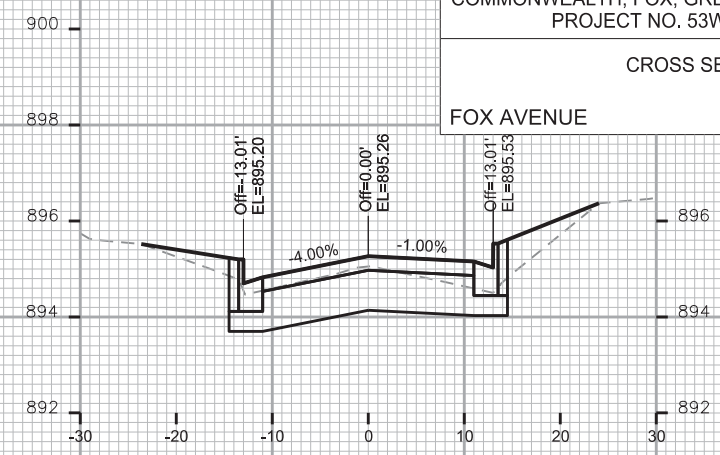

STA. 42+50

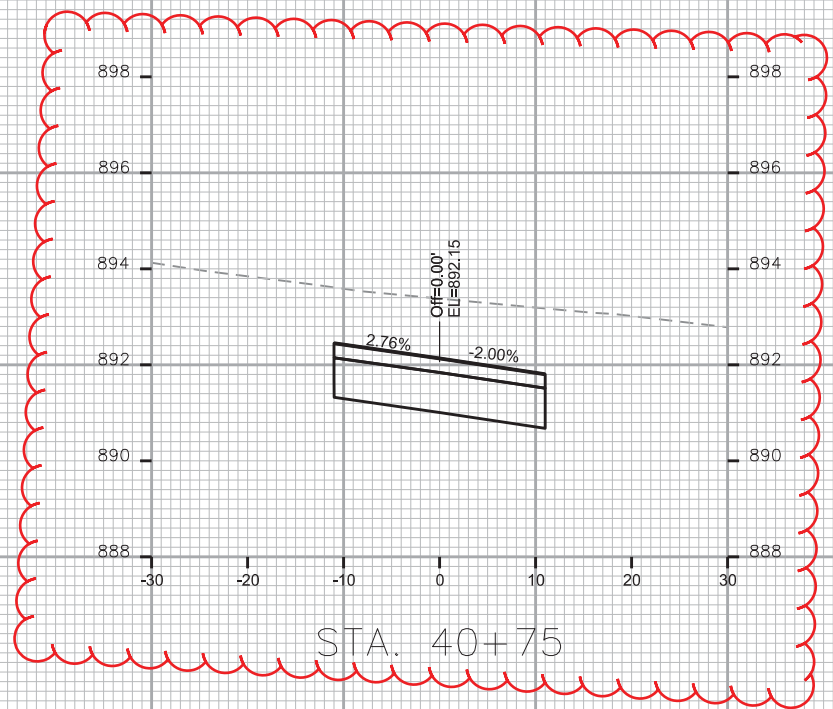

STA. 40+75

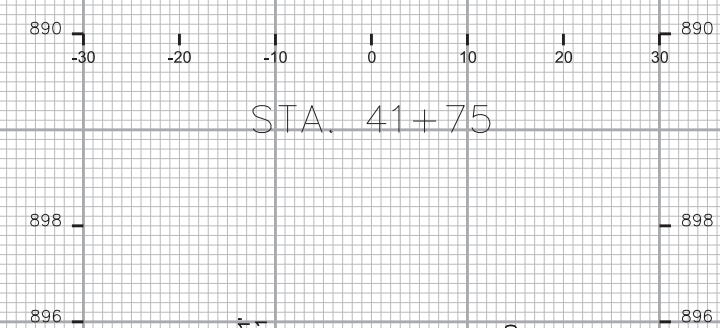

STA. 41+50

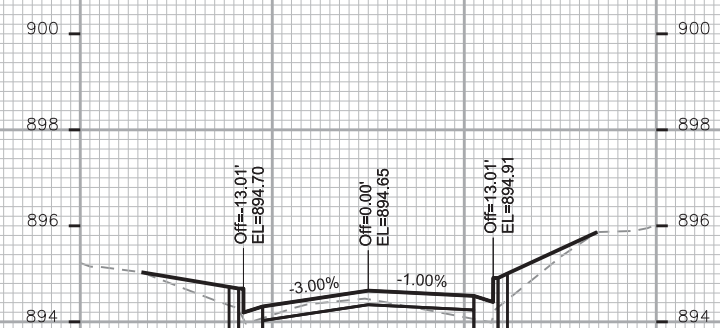

STA. 42+25

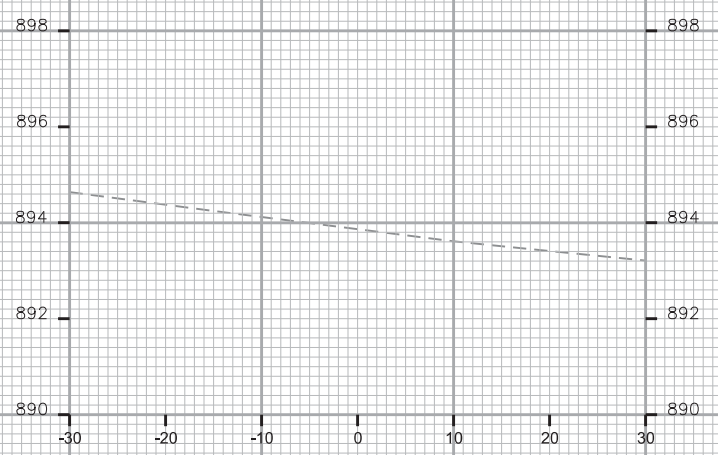

STA. 40+54

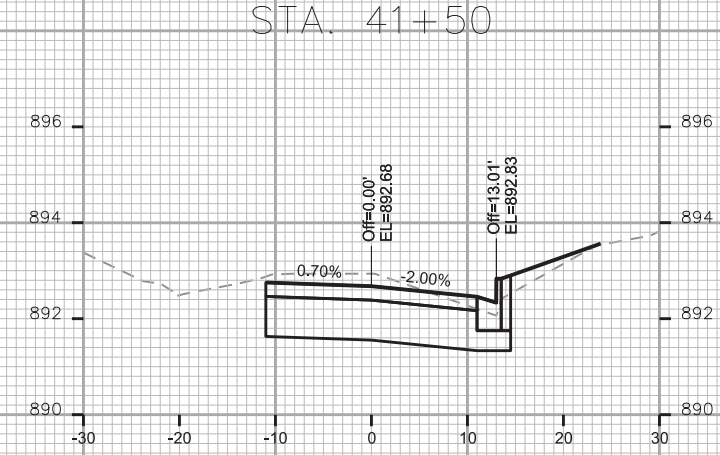

STA. 41+25

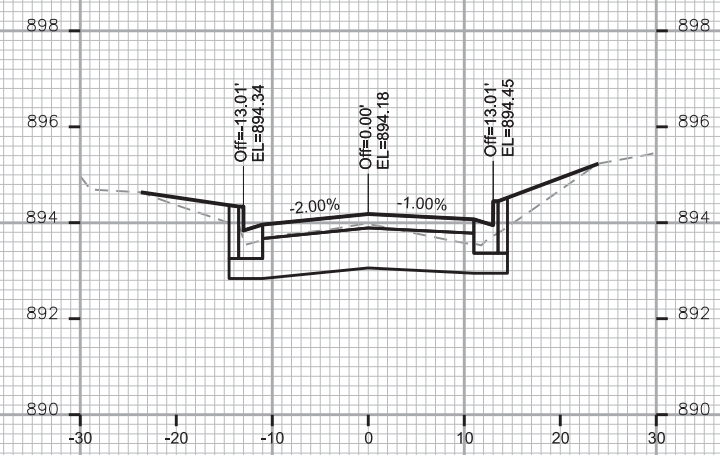

STA. 42+00

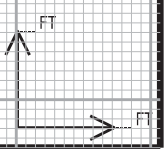

PLOT SCALE: _____

PLOT NAME: _____

REV. DATE: _____

ORIGINATOR: CITY OF MADISON, STREETS DIVISION

FILE NAME: _____

DATE: _____

CROSS SECTIONS
FOX AVENUE CITY OF MADISON

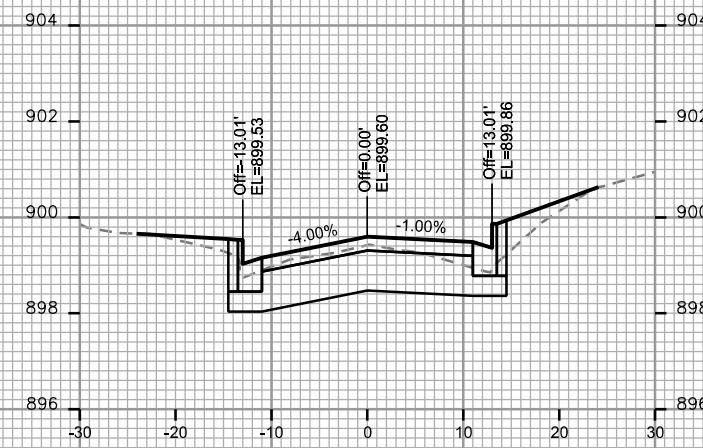
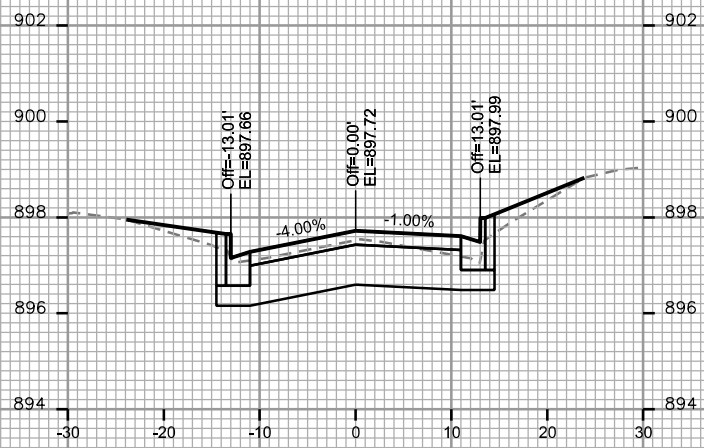
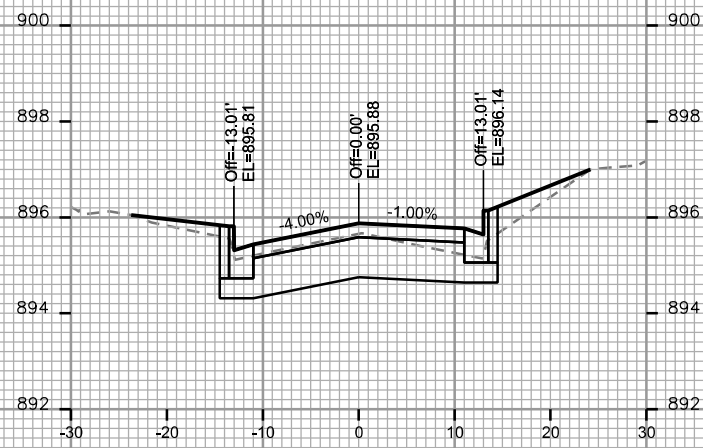
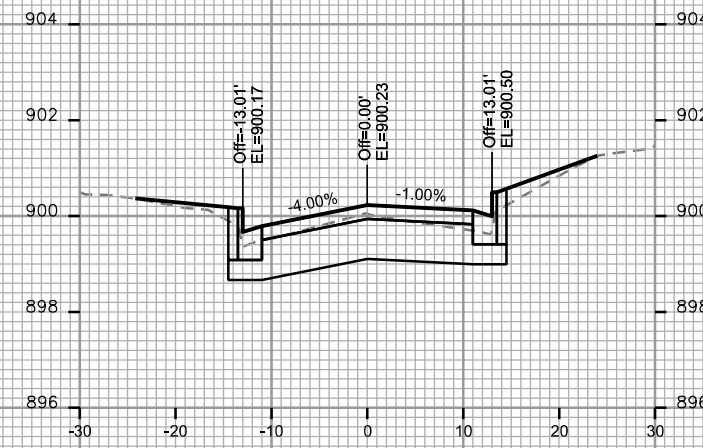
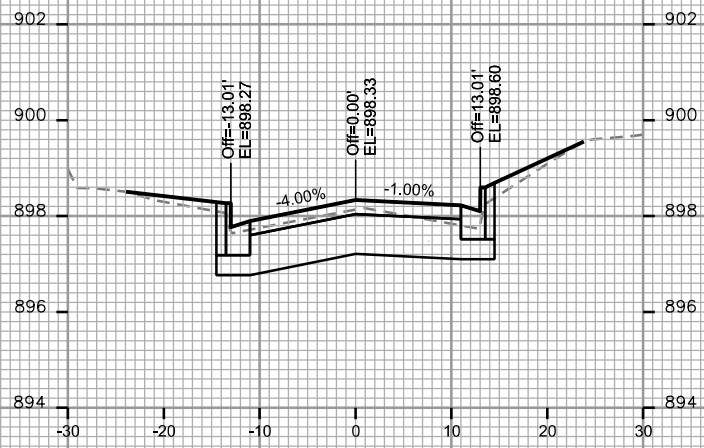
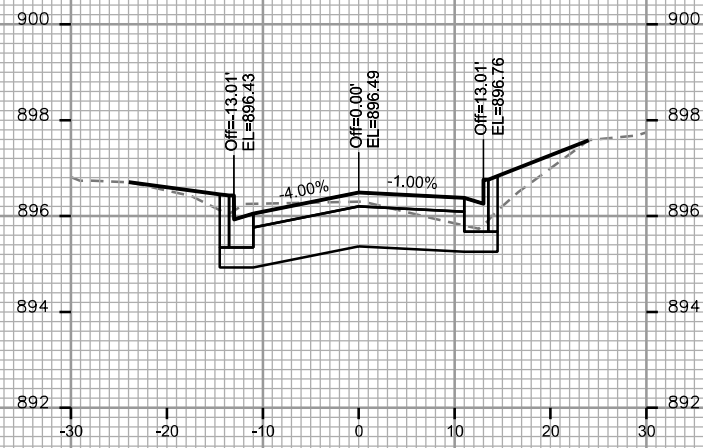
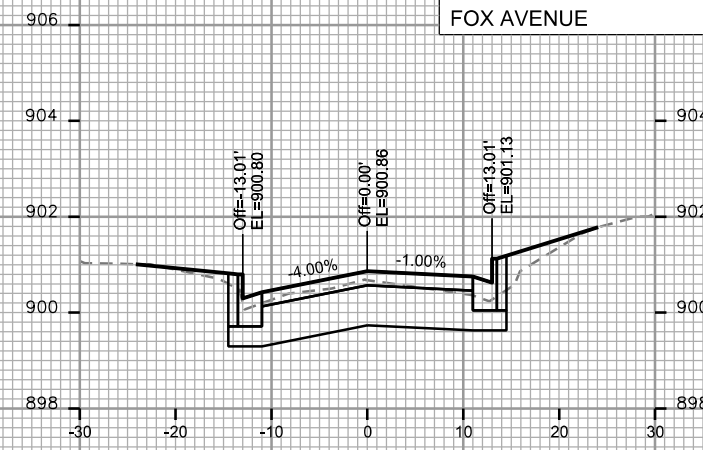
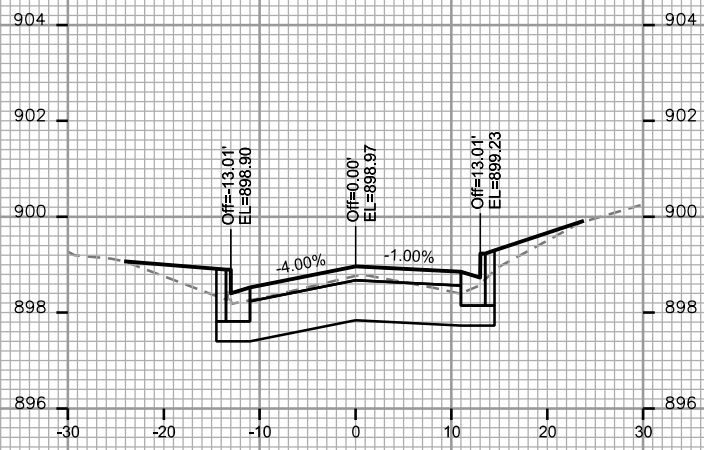
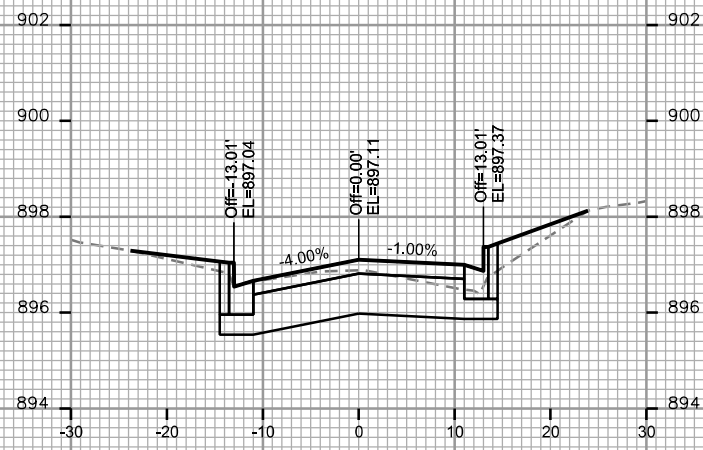

PLOT SCALE: _____

PLOT NAME: _____

REV. DATE: _____

ORIGINATOR: CITY OF MADISON - STREETS DIVISION

FILE NAME: _____

DATE: _____

CROSS SECTIONS

FOX AVENUE

CITY OF MADISON

PLOT SCALE: _____

PLOT NAME: _____

REV. DATE: _____

ORIGINATOR: CITY OF MADISON - STREETS DIVISION

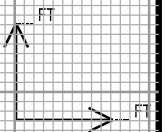
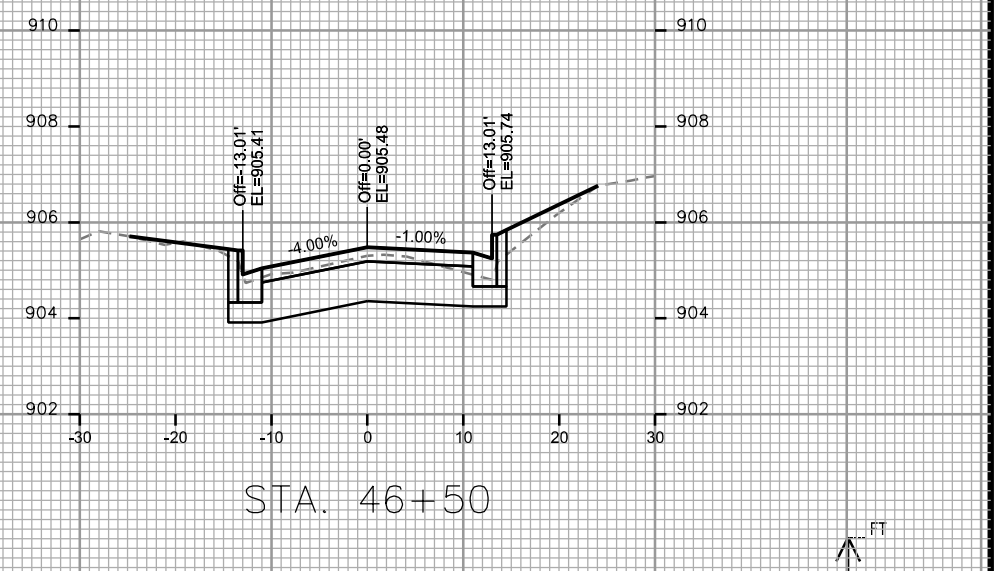
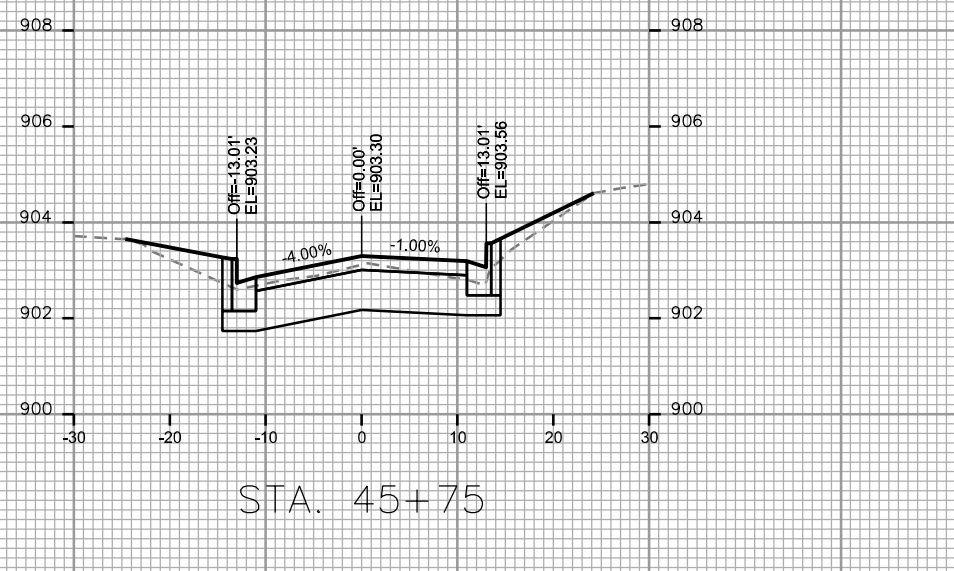
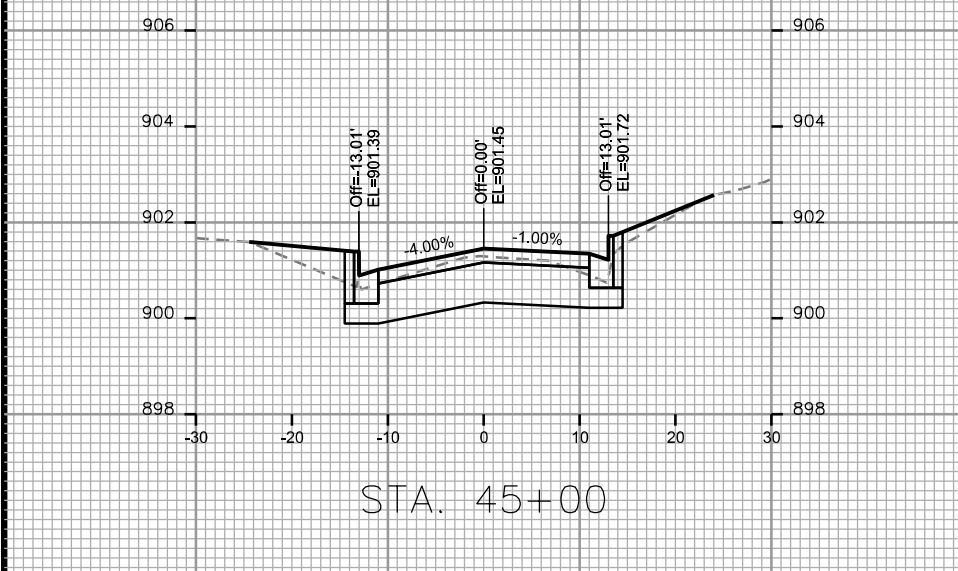
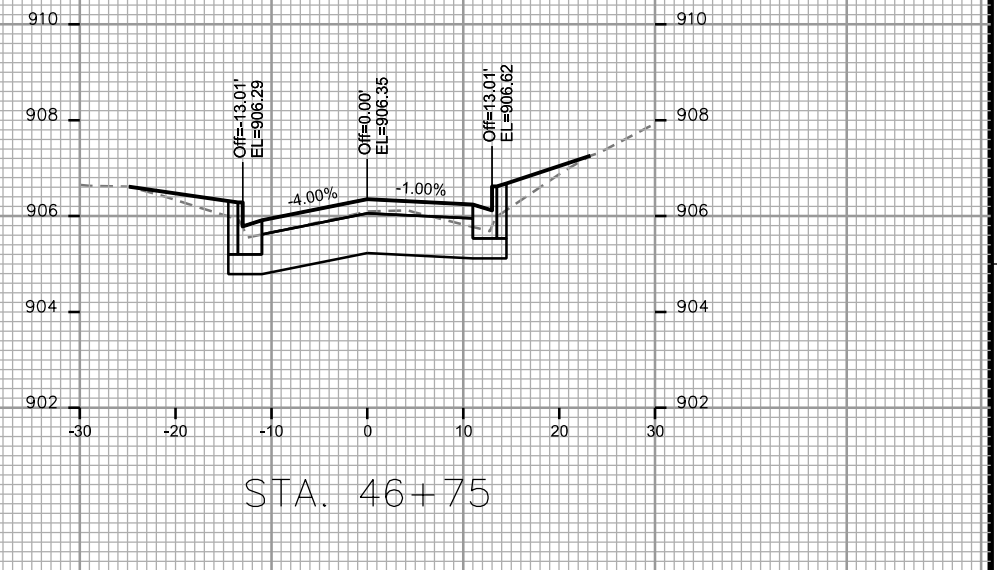
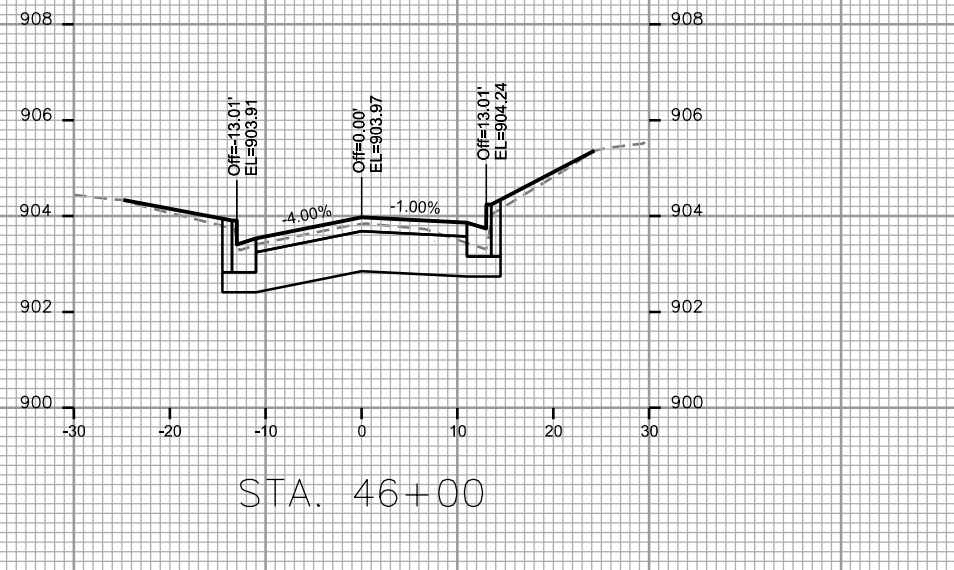
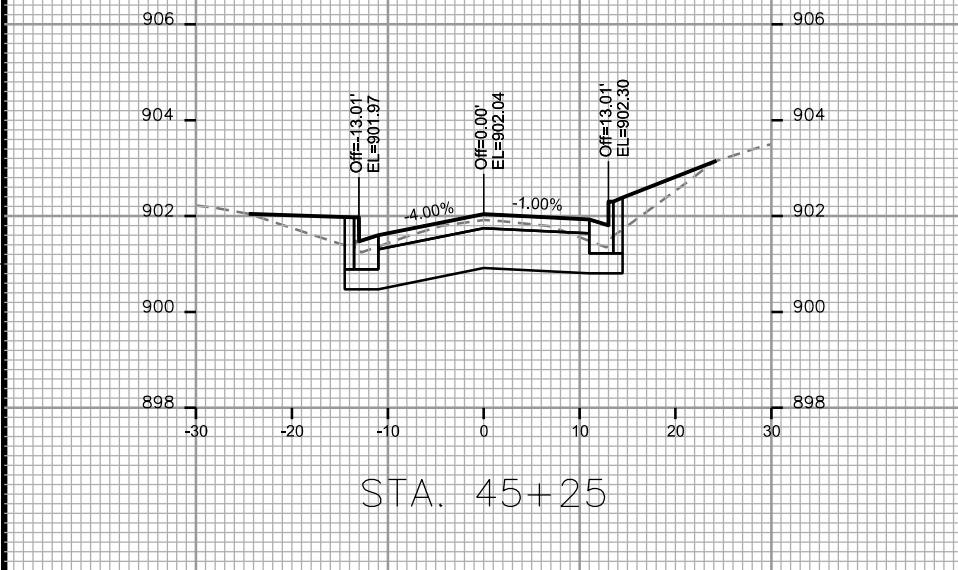
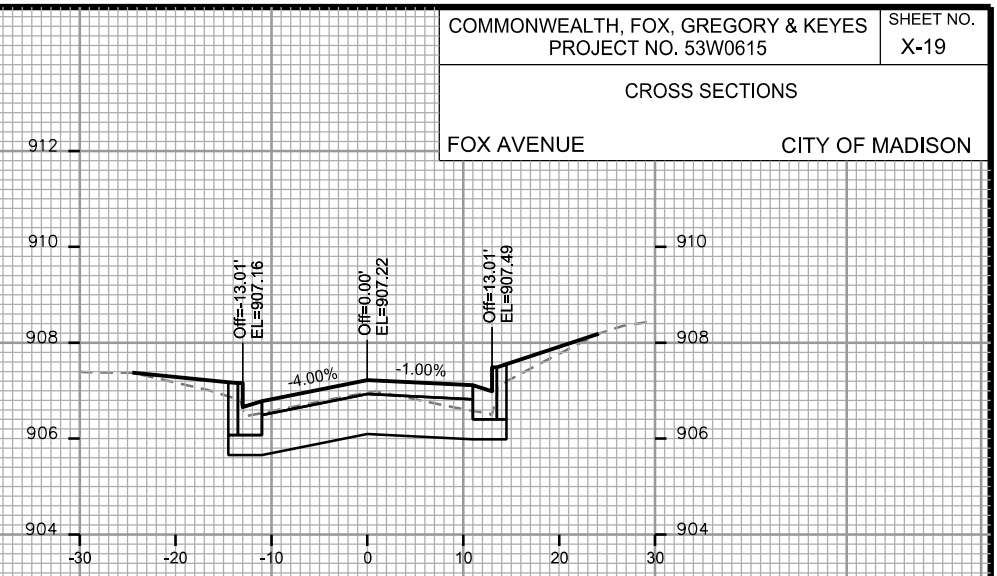
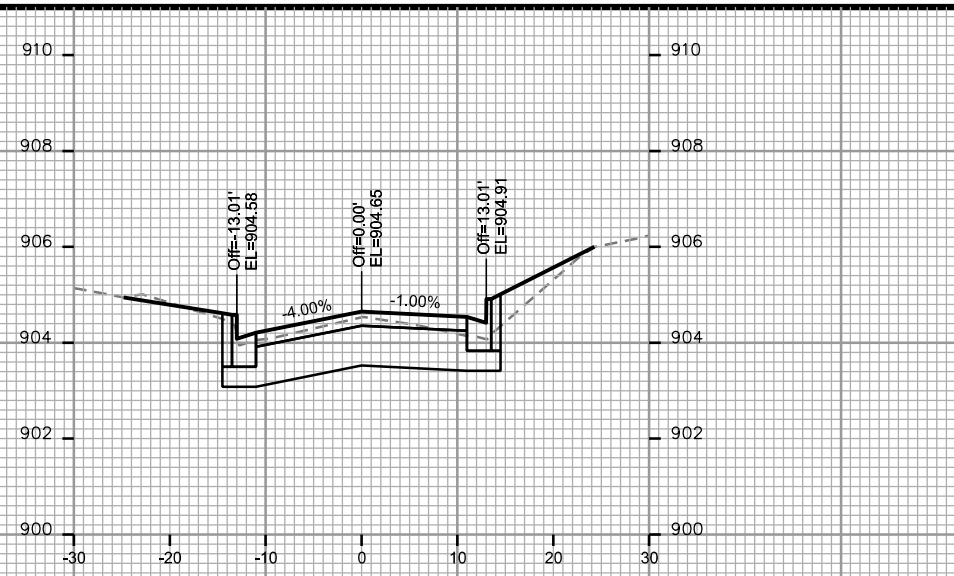
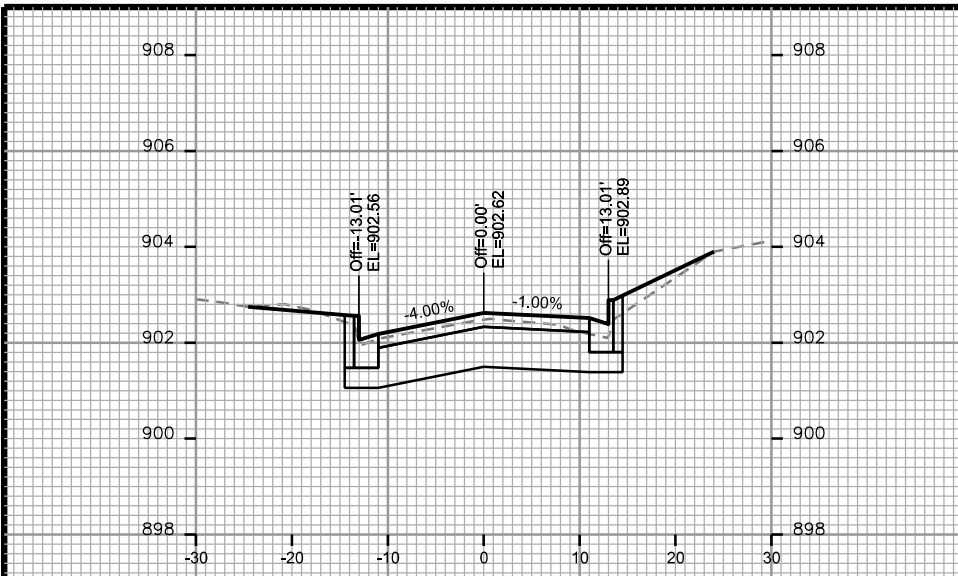

CROSS SECTIONS

FOX AVENUE

CITY OF MADISON

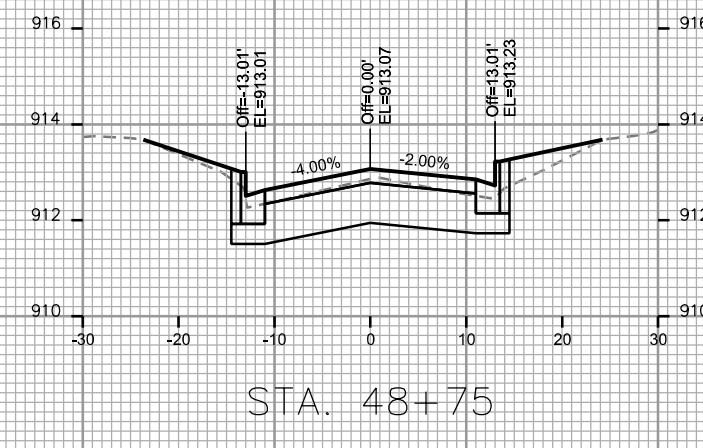
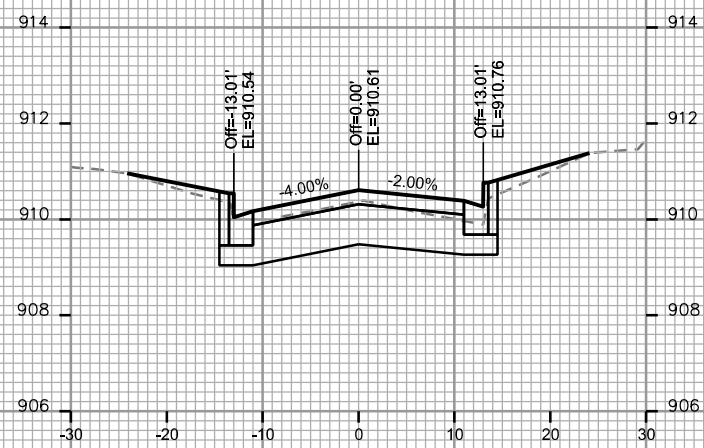
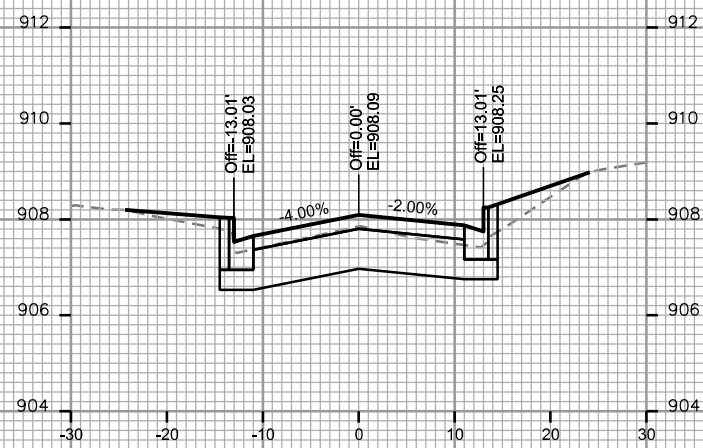
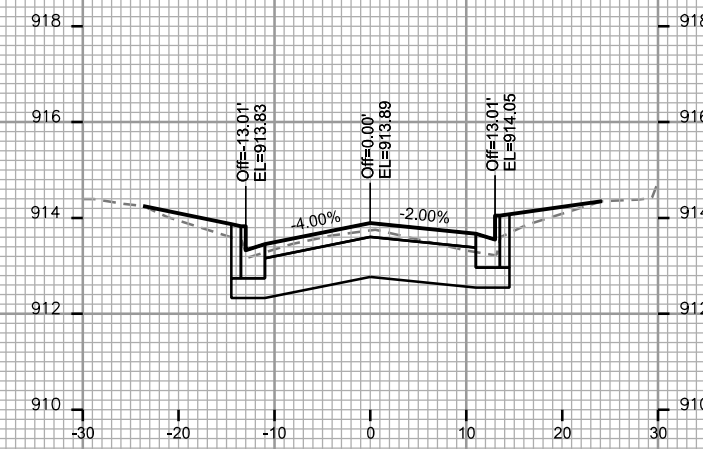
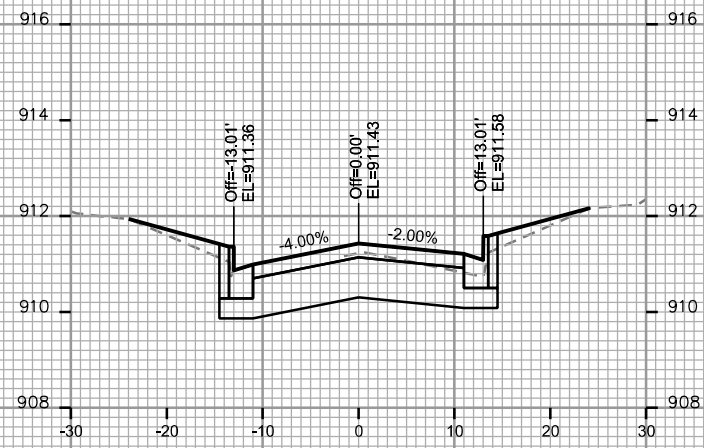
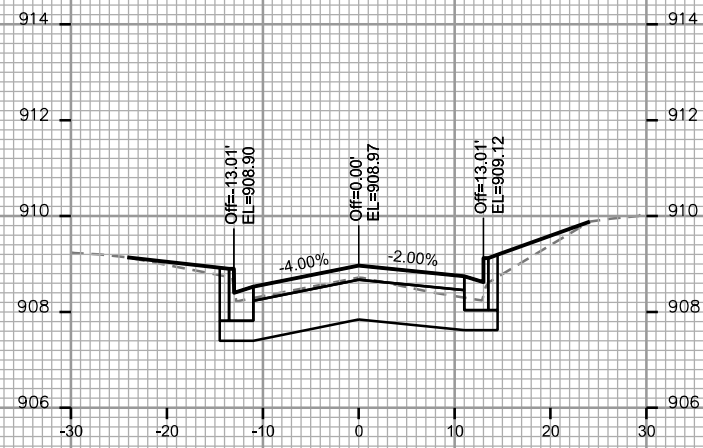
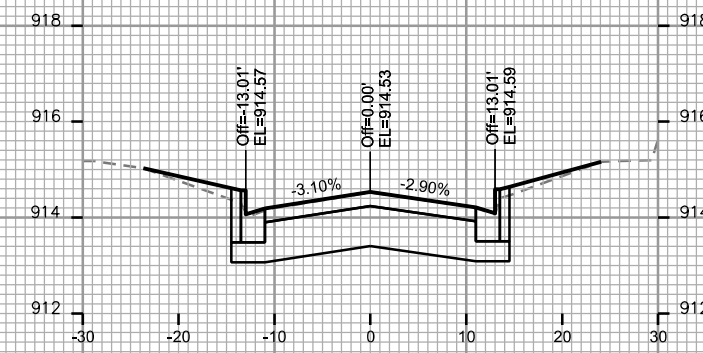
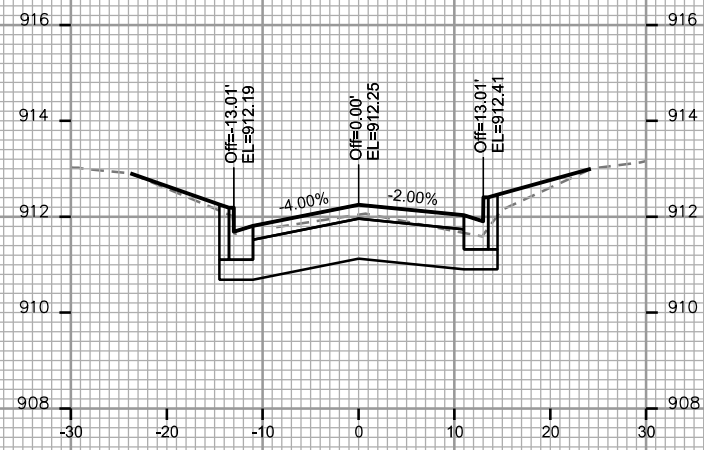
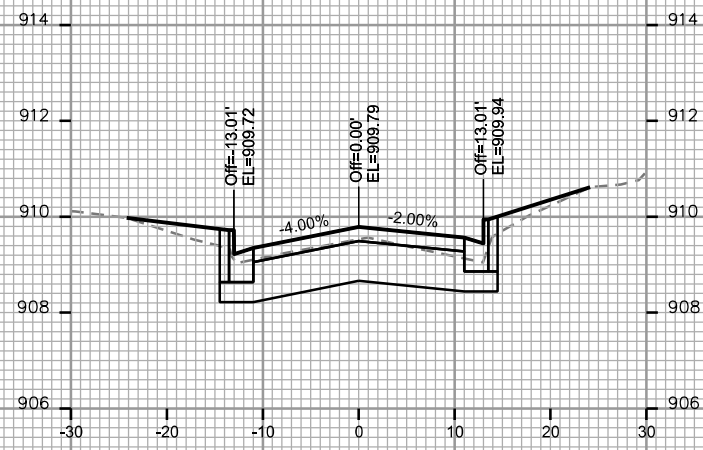

PLOT SCALE: _____

PLOT NAME: _____

REV. DATE: _____

ORIGINATOR: CITY OF MADISON - STREETS DIVISION

FILE NAME: _____

DATE: _____

CROSS SECTIONS
GREGORY STREET CITY OF MADISON

PLOT SCALE: _____

PLOT NAME: _____

REV. DATE: _____

ORIGINATOR: CITY OF MADISON, STREETS DIVISION

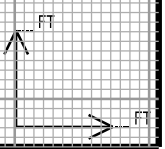
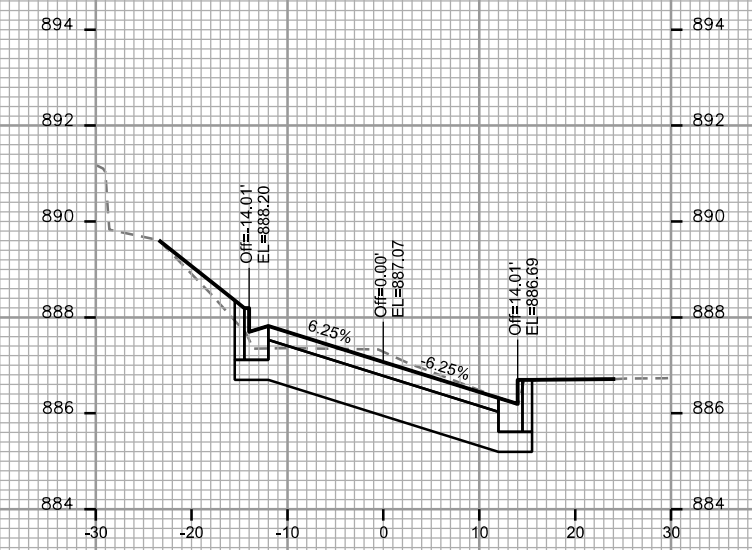
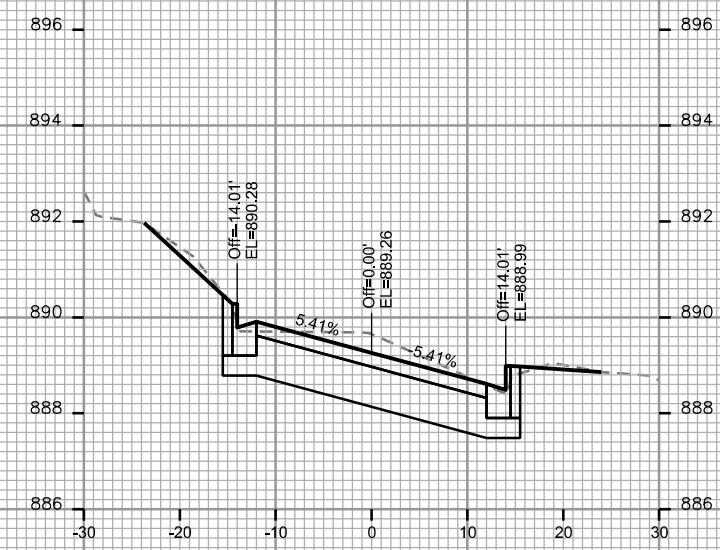
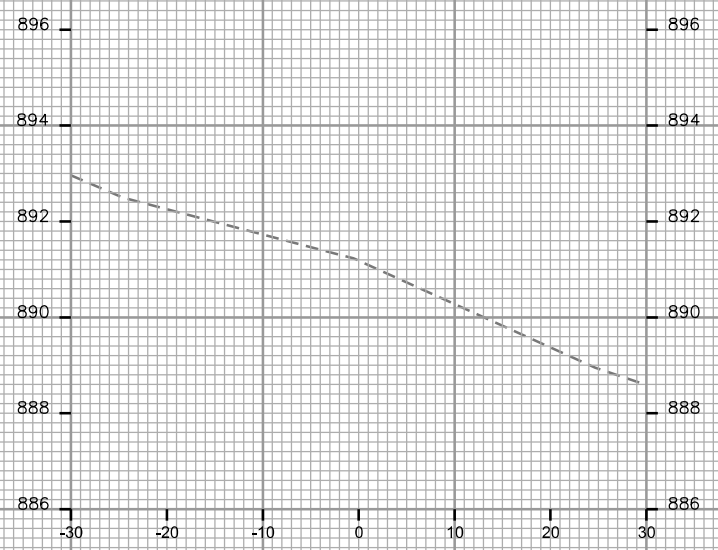
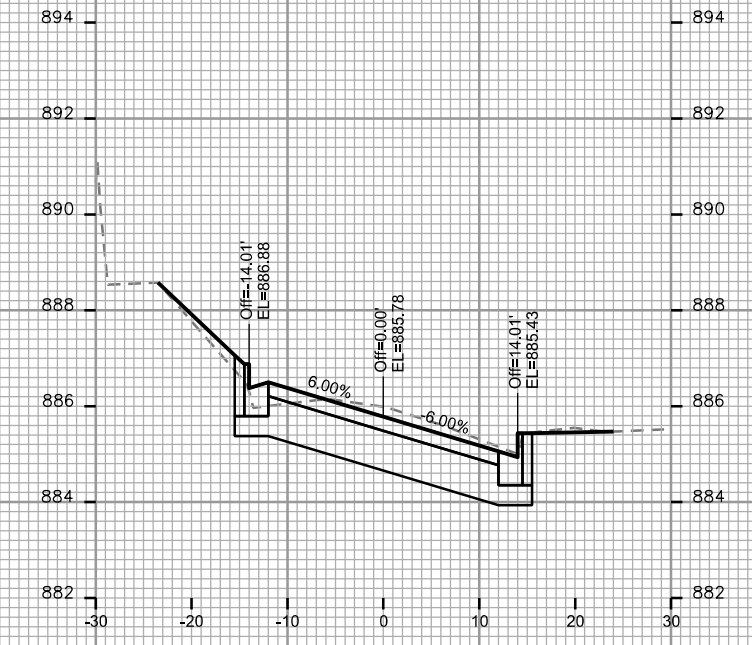
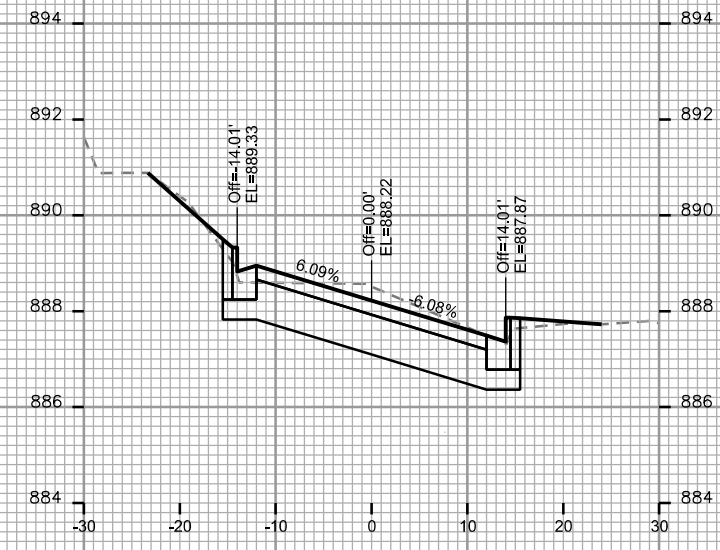
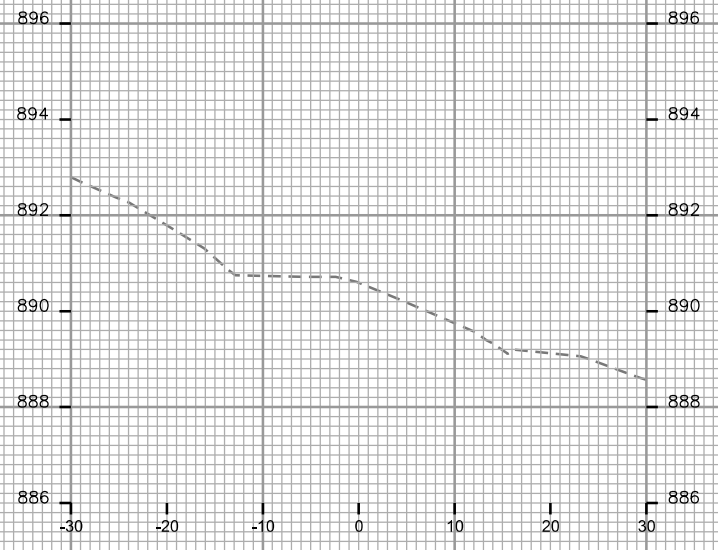

CROSS SECTIONS
GREGORY STREET CITY OF MADISON

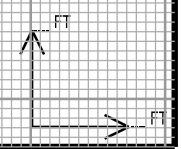
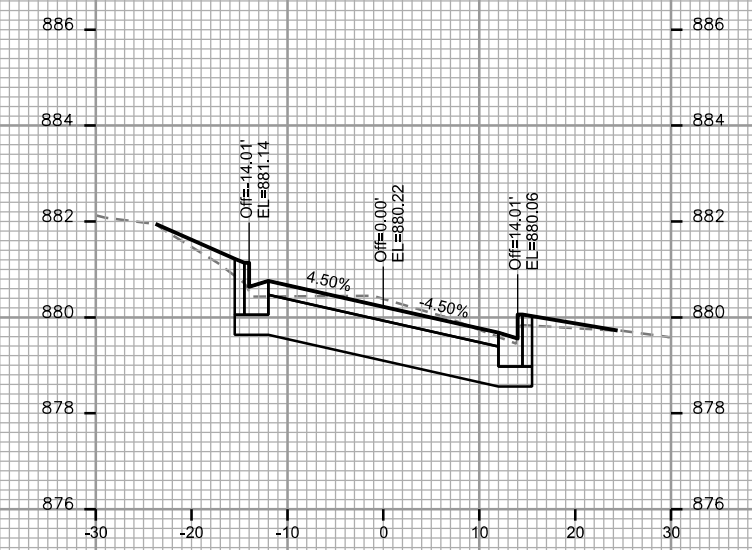
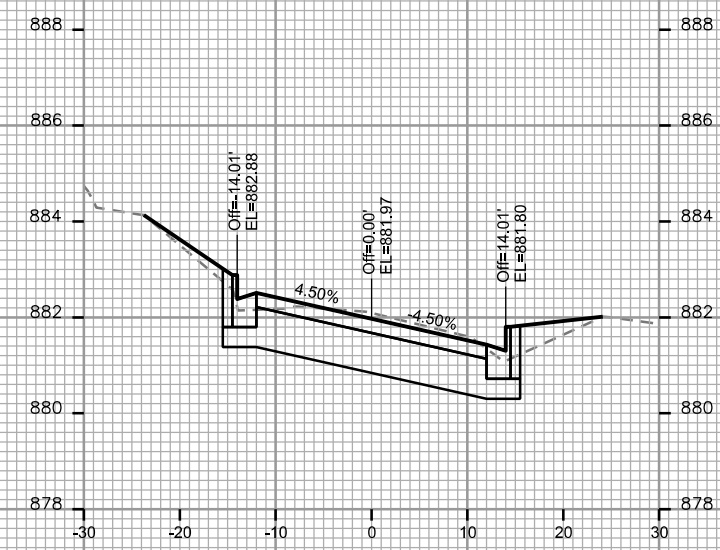
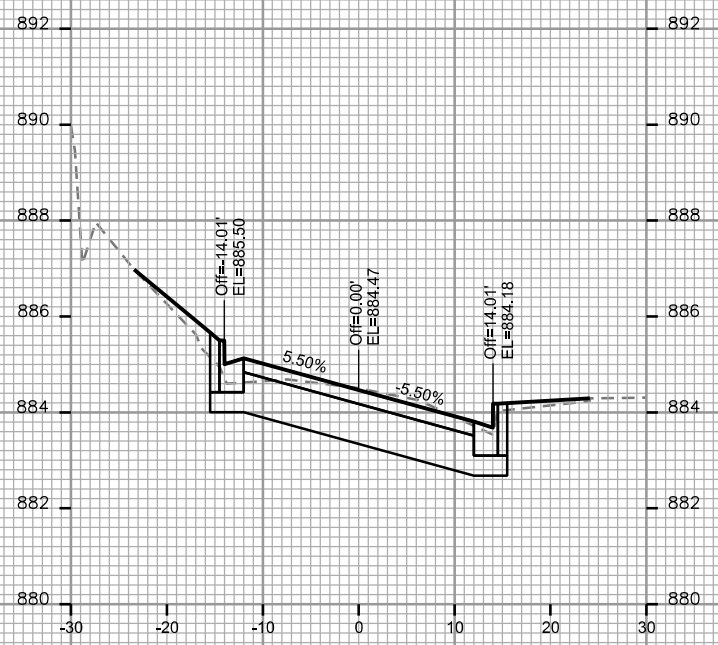
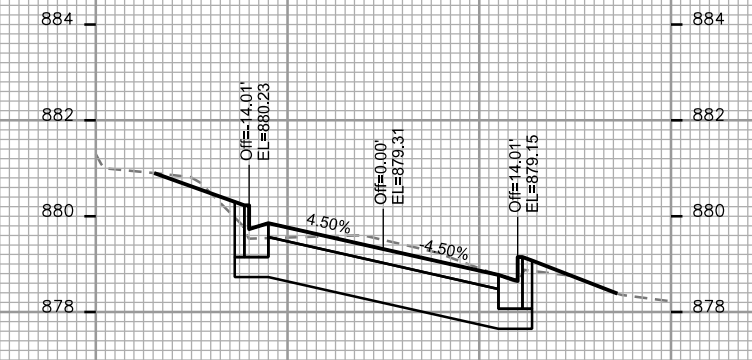
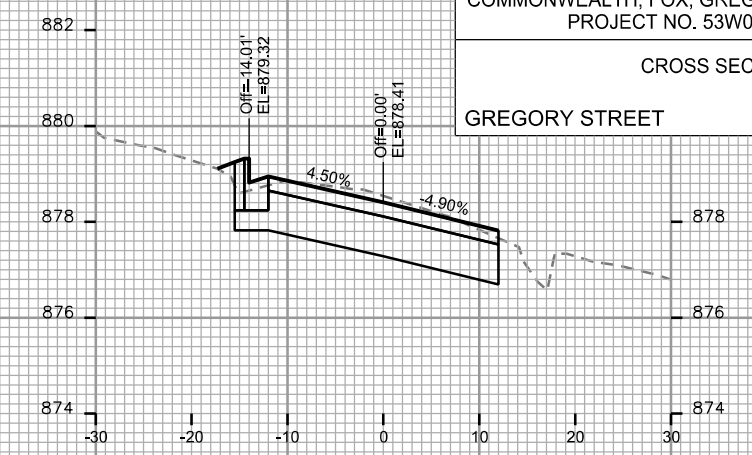
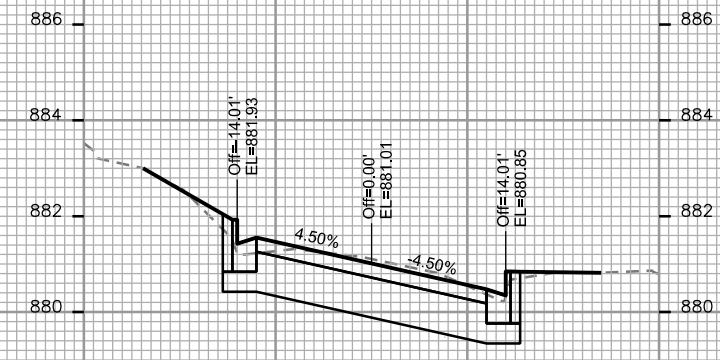
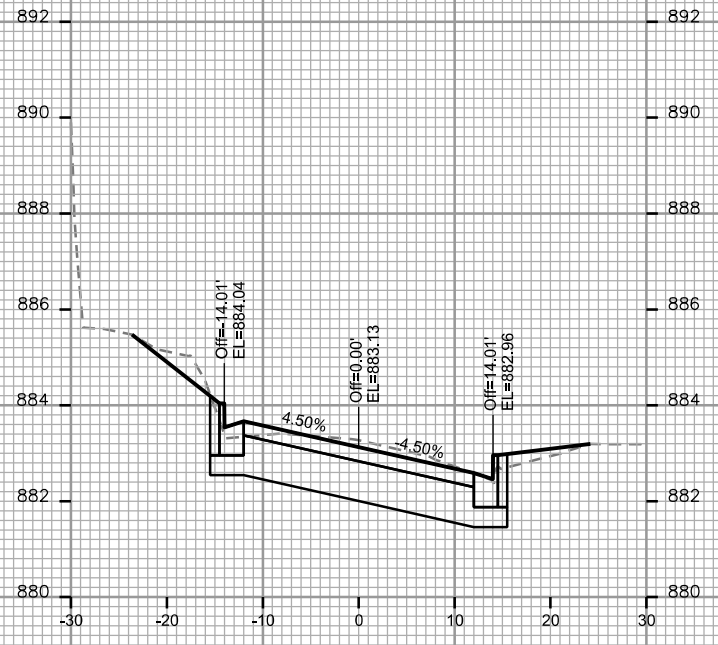

PLOT SCALE: _____
PLOT NAME: _____

REV. DATE: _____

ORIGINATOR: CITY OF MADISON, STREETS DIVISION

CROSS SECTIONS
KEYES AVENUE CITY OF MADISON

PLOT SCALE: _____

PLOT NAME: _____

REV. DATE: _____

ORIGINATOR: CITY OF MADISON, STREETS DIVISION

